

APPENDIX B – REVISION JUNE 2018

This revision of Appendix B of IECA (2008) is the finalised version of the draft release in December 2016 following industry consultation.

IECA acknowledges the financial support provided by the Queensland Government to deliver this update of Appendix B of the 2008 Best Practice Erosion and Sediment control document.

What Are the Major Changes from the ORIGINAL (2008) version?

We have revised Appendix B to include the use of Type A and Type B basins for fine-grained or dispersive soils where assisted settling of sediment occurs as runoff passes through the basin rather than the capture-treat-release approach adopted by Type D/F basins. The concept of continuous flow basins has been adapted from New Zealand. The following provides a brief description:

- Type A – similar to those originally developed in Auckland (under TP-90 guidelines). Type A basins include an automated chemical dosing system and a decant structure at the outlet.
- Type B – incorporate an automated chemical dosing system but no decants. These can be used for catchments with shorter disturbance timeframes.

What Are the Major Changes from the DRAFT (2016) version?

The major changes from the draft release and this final release are:

- Inclusion of symbols and abbreviations.
- Modifying the sizing of Type A basins based on Jar testing rather than a nominated particle size.
- New technical notes to help designers determine the depth of the sediment storage zone (D_{SS}) based on D_s , V_s , m.
- Changing the minimum free water zone depth to solely 0.2 m (remove the $10\%V_s$ requirement).
- More description of the purpose of Type B basins.
- Changes to the technical notes on the possible retention of water in Type A and Type B basins.

Why the Change?

Continuous flow sediment basins have been in use in New Zealand since the 1990s with great success. A major constraint on performance for Type D/F basins (capture-treat-release approach) is the basins overtopping during larger storm events and during consecutive rainfall events prior to treating and releasing. Type A and B basins will allow for treatment during both of these scenarios producing higher treatment efficiency and improved environmental outcomes.

Appendix B

Sediment basin design and operation

This appendix provides guidance on the design and operation of sediment basins. Its function within this document is both educational and prescriptive.

Discussion within this appendix will be limited to the design of short-term sediment basins typically used during the construction phase of civil works, and the more permanent basins used on long-term soil disturbances such as landfills, quarries and mine sites. This appendix, however, does not discuss the design of permanent sedimentation basins used for stormwater quality management within urban areas.

B1 Introduction

A sediment basin is a purpose built dam designed to collect and settle sediment-laden water. It usually consists of an inlet chamber, a primary settling pond, a decant system, and a high-flow emergency spillway.

Sediment basins generally perform two main functions: firstly the rapid settlement of coarse-grained sediment particles (e.g. sand and coarse silt) during all storm events that flow through the basin—this includes storms that may exceed the nominated design storm. Secondly the settlement of fine-grained particles (e.g. fine silt and clay) from waters that are allowed to pass through the basin under controlled (design flow) conditions.

Even though the sizing of a particular sediment basin may be based on storm events of an average recurrence interval (ARI) of 1 to 5 year, this does **not** mean the basin will be able to successfully treat all stormwater runoff from all 'real' storms with a recurrence interval equal to the 'design storm' recurrence interval—this is because 'real' storms can contain complex rainfall patterns that are beyond those conditions assessed during the development of the basin's design procedures.

It is the ability of sediment basins to reduce turbidity levels that allows these Type 1 sediment control systems to significantly reduce the potential ecological harm caused by urban construction. To achieve this aim, *Sediment Basins* need to be designed and operated in a manner that produces near-clear water discharge (i.e. total suspended solids concentrations not exceeding 50 mg/L), especially following periods of light rainfall.

Technical Note B1 – Protection of minor streams

The discharge of clear water from sediment basins following periods of light rainfall is particularly important because it is during such rainfall conditions that many receiving waters, such as minor creek systems, have insufficient base flow to flush-out and/or dilute any turbid stormwater runoff that may have entered the receiving water. However, this does **not** imply that the proper operation of sediment basins is not important during moderate to heavy rainfall. For further discussion on this issue, refer to Principle 6.2 in Chapter 2.

Symbols and abbreviations:

- A = area of the drainage catchment connected to the basin [ha]
 A = top surface area (as used in the description of prismatic volumes)
 A_b = surface area at base of volume (as used in the description of prismatic volumes)
 A_c = surface area at top of volume (as used in the description of prismatic volumes)
 A_i = area of surface area 'i' (used in the calculation of $C_{V (comp.)}$)
 A_m = surface area at mid depth (as used in the description of prismatic volumes)
 A_0 = surface area of primary drainage holes [m^2]
 A_s = average surface area of settling zone = V_s/D_s [m^2]
 $A_{S(min)}$ = minimum, average surface area of the settling zone [m^2]
 B = width of bottom edge (as used in the description of prismatic volumes)
 C_d = discharge coefficient (orifice flow parameter)
 C_v = volumetric runoff coefficient (hydrology term)
 $C_{V (comp.)}$ = composite volumetric runoff coefficient
 $C_{V,i}$ = volumetric runoff coefficient for surface area 'i'
 d = diameter of sediment particle [m]
 D = depth of volume (as used in the description of prismatic volumes)
 D_s = depth of the settling zone (typically measured from the spillway crest)
 g = acceleration due to gravity (typically adopt 9.8 m/s^2) [m/s^2]
 H = head of water above orifice [m]
 H_e = hydraulic efficiency correction factor (use in Type C basin design)
 I = average rainfall intensity [mm/hr]
 $I_{X \text{ yr, } 24 \text{ hr}}$ = average rainfall intensity for an X-year, 24-hour storm [mm/hr]
 $I_{(1 \text{ yr, } 120 \text{ hr})}$ = average rainfall intensity for a 1 in 1 year ARI, 120 hr storm [mm/hr]
 K = an equation coefficient that varies with the design event (X) and the low-flow decant rate (Q_A)
 K_1 & K_2 = equation constants
 K_s = sediment settlement coefficient = inverse of the settling velocity of the critical particle size [s/m]
 L = length of top surface (as used in the description of prismatic volumes)
 L_1 & L_2 = average length of segments of a divided basin [m]
 L_s = average length of the settling zone [m]
 $L_{S(critical)}$ = the length of the settling zone in a Type B basin at which point the supernatant velocity becomes critical and sediment re-suspension could potentially occur [m]
 m = constant bank slope around a volume (as used in the description of prismatic volumes)

- P = circumference of the base of a volume (as used in the description of prismatic volumes)
- Q = design discharge [m^3/s]
- Q1 = peak discharge for the critical-duration, 1 in 1 year ARI design storm [m^3/s]
- $R_{(Y\%,5\text{-day})}$ = depth of rainfall for the Y%, 5-day storm [mm]
- s = specific gravity of critical sediment particle
- S = lateral spacing of multiple inflow pipes
- T = de-watering time for an orifice-controlled decent system [hours]
- v = velocity [m/s]
- v_C = flow velocity of the clear water supernatant [m/s]
- v_F = design settling velocity of the sediment floc [m/hr]
- v_p = particle settling velocity [m/s]
- V = volume (as used in the description of prismatic volumes)
- V_S = volume of the settling zone [m^3]
- W = width of top surface (as used in the description of prismatic volumes)
- W_e = effective basin/pond width [m]
- W_S = average width of the settling zone [m]
- X = the nominated design storm event ARI (average recurrence interval) expressed in 'years'
- μ = kinematic viscosity of the water at a given temperature [m^2/s]

Terms used almost exclusively for Type A & B basins:

- A_B = surface area of the basin at base (floor) of the basin [m²]
 A_C = surface area of the basin at the elevation of the spillway crest [m²]
 A_{FW} = surface area of the basin at the top of the free water zone [m²]
 A_{MS} = surface area of the basin at the mid elevation of the settling zone = A_S
 A_{SS} = surface area of the basin at the top of the sediment storage zone [m²]
 D_F = depth to the settled sediment floc measured from the water surface [m]
 D_{FW} = depth (thickness) of the free water zone [m]
 D_S = depth (thickness) of the nominated settling zone [m]
 D_{SS} = depth (thickness) of the sediment storage zone [m]
 D_T = depth of the basin from the spillway crest to the base = $D_S + D_F + D_{SS}$
 K_1 = equation coefficient
 K_2 = equation coefficient = V_{S1}
 K_3 = equation coefficient
 L_B = length of the basin at base (floor) of the basin [m]
 L_C = length of the basin at the elevation of the spillway crest [m]
 L_{FW} = length of the basin at the top of the free water zone [m]
 L_{MS} = length of the basin at the mid elevation of the settling zone [m]
 L_{SS} = length of the basin at the top of the sediment storage zone [m]
 Q_A = low-flow decant rate per hectare for the contributing catchment [m³/s/ha]
 $Q_{A \text{ (optimum)}}$ = the optimum low-flow decant rate such that the basin's dimensions requirements for pond volume and pond surface area are simultaneously minimised [m³/s/ha]
 Q_L = the maximum low-flow decant rate prior to flows overtopping the emergency spillway = $Q_A * A$ [m³/s]
 V_{S1} = the minimum possible settling zone volume that can exist for given values of D_S , m , and $V_{SS} = 0.3V_S$ at the point where the base width (W_B) approaches zero metres [m³]
 V_{S2} = a low-range value of the settling zone volume that can be used to interpolate values of D_S/D_{SS} [m³]
 W_B = width of the basin at base (floor) of the basin [m]
 W_C = width of the basin at the elevation of the spillway crest [m]
 W_{FW} = width of the basin at the top of the free water zone [m]
 W_{MS} = width of the basin at the mid elevation of the settling zone [m]
 W_{SF} = average basin width of the clear water above the floc (i.e. measured over a depth of D_F , not D_S)
 W_{SS} = width of the basin at the top of the sediment storage zone [m]

B2 Design Procedure

It is noted that the following design procedure may not address all relevant design issues on all sites. Prior to using this design procedure, advice should be sought from the relevant authority regarding any additional design requirements.

Design steps:

Step	Action		Basins	Page
Step 1	Assess the need for a sediment basin		All types	B6
Step 2	Select basin type		All	B7
Step 3	Determine basin location		All	B10
Step 4	Divert up-slope 'clean' water		All	B13
Step 5	Select internal and external bank gradients		All	B14
Step 6a	Sizing Type A basins	Subdivided into several steps labelled 1A-10A & 1B-7B	Type A (only)	B15
Step 6b	Sizing Type B basins		Type B (only)	B25
Step 6c	Sizing Type C basins		Type C (only)	B31
Step 6d	Sizing Type D basins		Type D (only)	B35
Step 7	Define the sediment storage volume		All	B40
Step 8	Design of flow control baffles		Type A, B & C	B41
Step 9	Design the basin's inflow system		All	B44
Step 10	Design the primary outlet system		Type A & C	B52
Step 11	Design the emergency spillway		All	B60
Step 12	Assess the overall dimensions of the basin		All	B62
Step 13	Locate maintenance access (de-silting)		All	B64
Step 14	Define the sediment disposal method		All	B64
Step 15	Assess the need for safety fencing		All	B64
Step 16	Define the rehabilitation process for the basin area		All	B65
Step 17	Define the basin's operational procedures (this step also directs designers to Section B3 for information on chemical dosing)		All	B69

Section B3 provides information on coagulants and flocculants (Type A, B & D basins)

Section B4 provides a *draft* specification, which was originally prepared for Type C basins, but can be adapted to Type A, B & D basins.

Section B5 provides general information on basin maintenance.

Step 1: Assess the need for a sediment basin

A sediment basin typically operates as a Type 1 sediment trap; however, if the basin's critical dimensions (e.g. volume and/or surface area) are less than 'ideal', the basin may need to be classified as a Type 2 system.

The need for a sediment basin is usually governed by the potential soil loss risk; but may also be triggered by the water quality objectives of a given drainage catchment.

As a general rule, the further upstream a soil disturbance is within a coastal drainage catchment, the greater the need for turbidity control due to the greater total reach length over which turbid runoff can potentially cause environmental harm. For inland waterways, such as the Murray-Darling basin, the need for turbidity control is very site specific, and guidance should always be sought from local authorities.

The recommended application of Type 1 sediment control devices (i.e. sediment basins) is presented in Table B1. Table B1 supersedes Table 4.5.1 presented within the 2008 edition of Chapter 4. For further information on Type 1, Type 2 and Type sediment control classification refer to Chapter 4.

Table B1 – Sediment control standard (default) based on soil loss rate

Catchment Area (m ²) ^[1]	Soil loss (t/ha/yr) ^[2]			Soil loss (t/ha/month) ^[3]		
	Type 1	Type 2	Type 3	Type 1	Type 2	Type 3
250	N/A	N/A	[4]	N/A	N/A	[4]
1000	N/A	N/A	All cases	N/A	N/A	All cases
2500	N/A	> 75	75	N/A	> 6.25	6.25
>2500	> 150	150	75	> 12.5	12.5	6.25
> 10,000	> 75	N/A	75	> 6.25	N/A	6.25

Notes:

- [1] Area is defined by the catchment area draining to a given site discharge. Sub-dividing a given drainage catchment shall not reduce its 'effective area' if runoff from these sub-areas ultimately discharges from the site at the same general location. The 'area' does not include any 'clean' water catchment that bypasses the sediment trap. The catchment area shall be defined by the 'worst case' scenario, i.e. the largest effective area that exists at any instance during the soil disturbance.
- [2] Soil loss defines the maximum allowable soil loss rate (based on RUSLE analysis) from a given catchment area. A slope length of 80 m should be adopted within the RUSLE analysis unless permanent drainage or landscape features reduce this length.
- [3] RUSLE analysis on a monthly basis shall only apply in circumstances where the timing of the soil disturbance is/shall be regulated by enforceable development approval conditions. When conducting monthly RUSLE calculations, use the worst-case monthly R-Factor during the nominated period of disturbance.
- [4] Refer to the relevant regulatory authority for assessment procedures. The default standard is a Type 3 sediment trap.
- [5] Exceptions to the use of sediment basins shall apply in circumstances where it can be demonstrated that the construction and/or operation of a sediment basin is not practical, such as in many forms of linear construction where the available work space or Right of Way does not provide sufficient land area. In these instances, the focus must be erosion control using techniques to achieve an equivalent outcome. The 'intent' shall always be to take all reasonable and practicable measures to prevent or minimise potential environmental harm.

Step 2: Select basin type

Selection of the type of sediment basin is governed by the site's location and soil properties as outlined in Table B2.

Table B2 – Selection of basin type

Basin type	Soil and/or catchment conditions ^[1]
Type A	The duration of the soil disturbance, within a given drainage catchment, exceeds 12 months. ^[2, 3, 4]
Type B	The duration of the soil disturbance, within a given drainage catchment, does not exceed 12 months. ^[2, 3, 4]
Type C	Less than 33% of soil finer than 0.02 mm (i.e. $d_{33} > 0.02$ mm) and no more than 10% of soil dispersive. ^[5, 6]
Type D	An alternative to a Type A or B basin when it can be demonstrated that automatic chemical flocculation is not reasonable nor practicable. ^[3]

Notes:

- [1] If more than one soil type exists on the site, then the most stringent criterion applies (i.e. Type A supersedes Type B/D, which itself supersedes Type C).
- [2] The duration of soil disturbance shall include only those periods when there is likely to be less than 70% effective ground cover (i.e. C-Factor of 0.05 or higher, refer to Appendix E (IECA, 2008)).
- [3] Because the footprints of Type A, B and D basins are similar, the issue of reasonableness and practicability comes down to whether or not effective automated dosing can be implemented. Situations where this is not practical are likely to occur only when the physical layout results in multiple inflow locations, and alternative configurations are not achievable.
- [4] Alternative measures such as batched sediment basins (i.e. enlarged Type D) may be implemented in lieu of Type A or B basins where it can be shown that such measures will achieve a commensurate performance outcome. Alternative designs should be able to demonstrate through long-term water-balance modelling: (i) the equivalent water quality outcomes of existing Type A basins in the local area; (ii) if local data on the performance of Type A basins is not available, at least 80% of the annual average runoff volume can achieve the specified WQO.
- [5] A Type C basin shall not be used if the adopted Water Quality Objectives (WQOs) specify turbidity levels and/or suspended solids concentrations for the site's discharged waters are unlikely to be achieved by a Type C basin. Particle settlement testing is recommended prior to adopting a Type C basin to confirm unassisted sediment settling rates, and to ensure that the Type C design will achieve the desired discharge water quality.
- [6] The percentage of soil that is dispersive is measured as the combined decimal fraction of clay (<0.002 mm) plus half the percentage of silt (0.002–0.02 mm), multiplied by the dispersion percentage (refer to Appendix C – *Soils and revegetation*).
- [7] For highly sensitive receiving environments, where higher than normal water quality standards are required, the solution maybe one or a combination of: a focus on erosion control, larger retention times (i.e. larger basin volume), and/or more efficient flocculants/coagulants.
- [8] The most appropriate flocculant/coagulant is likely to vary with the type of exposed soil. Consequently, there is need to proactively review the efficacy of these products over time.

Discussion:

Table B3 provides an overview of the design and operational features of the different sediment basins.

Table B3 – Overview of the design and operation features of various sediment basins

Basin	Features
Type A	<ul style="list-style-type: none"> • Type A basins are considered the most effective sediment traps for clayey soils. • Pond size is governed by both minimum volume and minimum surface area requirements. • Operation of the sediment basin relies on the installation of an automatic chemical dosing system. • A floating decant system collects water from the top of the water column during the storm event. • In most circumstances, the settling pond is required to be de-watered to the nominated static level prior to a rain event that is likely to produce runoff. • Temporary basins are typically sized for a the 1 year ARI, 24 hour storm event.
Type B	<ul style="list-style-type: none"> • Pond size is primarily governed by a minimum required surface area. • These basins are typically larger in volume and surface area than Type A basins. • Operation of the sediment basin relies on the installation of an automatic chemical dosing system. • Ideally the settling pond should be de-watered prior to a rain event that is likely to produce runoff; however, during dry conditions water may be retained in the pond as a source of water for usage on the construction site. • Temporary basins are typically sized for a discharge of 0.5 times the peak 1 in 1 year ARI critical duration storm.
Type C	<ul style="list-style-type: none"> • Type C basins are limited to works within non-dispersive, low-clay, sandy soils. • Pond size is governed by a minimum required surface area. • These basins are free-draining, which means they are normally 'empty' at the start of rainfall; however, under certain conditions water may be retained in the pond as supply a source of water for usage on the site. • Temporary basins are typically sized for a discharge of 0.5 times the peak 1 in 1 year ARI critical duration storm.
Type D	<ul style="list-style-type: none"> • Pond size is governed by a minimum required volume. • Operation of the sediment basin normally relies on chemical dosing, using either an automatic or manual chemical dosing system. • The settling pond is required to be de-watered to the bottom of the settling zone prior to a rain event that is likely to produce runoff. • Temporary basins are typically sized for an 80%ile, 5-day rainfall depth, depending on catchment conditions and risk.

Analysis of soil and water characteristics for the contributing catchment of each sediment basin is critical in selecting the chemical treatment requirements including the dosing system and coagulant/flocculant.

In some situations, analysis of the soil and water characteristics will also guide the selection of the basin type. If the local soil and water characteristics hinder the effective operation of a Type A or B basin, then sufficient justification must be provided documenting why an alternative sediment basin type has been adopted.

Soil characteristics such as low alkalinity and/or acidic soils can sometimes cause problems, but in some case these issues can be managed through broad scale soil management that will allow specific treatment systems to be feasible and effective. Determination of what actions to allow for an effective treatment system are considered reasonable and practicable an assessment is to be undertaken by a suitably qualified person. The assessment is to be well documented and include details on issues such as: constraints affecting automated treatment, receiving environment, area and length of exposure, erosion risk, and the project scope.

The sediment basin components and methodology utilised for Type A and B basins should always be adopted wherever practical. Even without a treatment system, the design approach promotes more effective settling compared to Type D basins that do not normally incorporate automatic dosing, forebays and hydraulically efficient settling pond designs. If automated chemical treatment is not incorporated into the operation of a basin, then the operational requirements will need to be modified to that presented for Type A and B basins.

Jar testing, in accordance with Section B3, is required in order to determine the chemical dosing requirements of sediment basins. It is recommended that this analysis is undertaken **prior** to designing the basins as the findings may influence the strategies adopted. It should be noted that the most suitable flocculant and/or coagulant is likely to vary with different soil types. Consequently, there is the need to proactively review the efficacy of these products over time as soil characteristics change during the various construction phases of the project.

Step 3: Determine basin location

All reasonable and practicable measures must be taken to locate sediment basins within the work site in a manner that maximises the basin's overall sediment trapping efficiency. Issues that need to be given appropriate consideration include:

- (i) Locate all basins within the relevant property boundary, unless the permission of the adjacent land-holder has been provided.
- (ii) Locate all basins to maximise the collection of sediment-laden runoff generated from within the site throughout the construction period, which extends up until the site is adequately stabilised against soil erosion, including raindrop impact.
- (iii) Do not locate a sediment basin within a waterway, or major drainage channel, unless it can be demonstrated that:
 - the basin will be able to achieve its design requirements, i.e. the specified treatment standard (water quality objective);
 - settled sediment will not be resuspended and washed from the basin during stream flows equal to, or less than, the 1 in 5 year ARI (18% AEP);
 - the basin and emergency spillway will be structurally sound during the design storm specified for the sizing of the emergency spillway.
- (iv) Where practical, locate sediment basins above the 1 in 5 year ARI (18% AEP) flood level. Where this is not practical, then all reasonable efforts must be taken to maximise the flood immunity of the basin.
- (v) The basin design should avoid disturbance to high water tables and/or potential to interception of groundwater.
- (vi) Avoid locating a basin in an area where adjacent construction works may limit the operational life of the basin.
- (vii) Assess and minimise secondary impacts such as disturbance to tree roots, particularly of significant individual trees. These impacts may extend to trees on adjacent lands (refer to AS4970 - *Protection of trees on development sites*).
- (viii) Ensure basins have suitable access for maintenance and de-silting.

If the excavated basin is to be retained as a permanent land feature following the construction period—for example as a stormwater detention/retention system—then the location of the basin may in part be governed by the requirements of this final land feature. However, if the desired location of this permanent land feature means that the basin will be ineffective in the collection and treatment of sediment-laden runoff, then an alternative basin location will be required.

Discussion:

It should be remembered that it is not always necessary to restrict the site to the use of just one sediment basin. In some locations it may be highly desirable to divide the work site into smaller, more manageable sub-catchments, and to place a separate basin within each sub-catchment.

Generally speaking, it is undesirable to divide a basin into a series of two or more in-line basins (i.e. basins operating in *series* rather than in *parallel*). Depending on the type of basins, several small basins operating in series can have significantly less sediment trapping efficiency than a single basin, even though the series of smaller basins may have the same total surface area or volume. This is because of the remixing that occurs when flow from one basin spills into, or is piped into, the subsequent basin. However, there are exceptions to this rule, such as in the following cases:

- (i) Type A basins where the combined basin volume satisfies the minimum volume requirement, and at least one of the basins is able to, on its own, satisfy the minimum surface area requirement.
- (ii) Type D basins where at least one of the basins has sufficient surface area and length to width ratio to satisfy the requirements of a Type C basin (Figure B2). The combined *settling volume* of the basins must not be less than that specified for a Type D basin.
- (iii) A series of Type C or D basins where each settling pond is connected by several pipes or culverts evenly spaced across the full width of the basin (Figure B3). Such a design must minimise the effects of inflow jetting from each pipe/culvert and allow an even distribution of flow across the full basin width. In such cases the minor sediment remixing that occurs as flow passes through the interconnecting pipes/culverts is usually compensated for by the improved hydraulic efficiency of the overall basin surface area.

In case (iii) above, the flow velocity through the interconnecting pipes/culverts should not exceed the relevant sediment re-suspension velocity specified in Step 8.

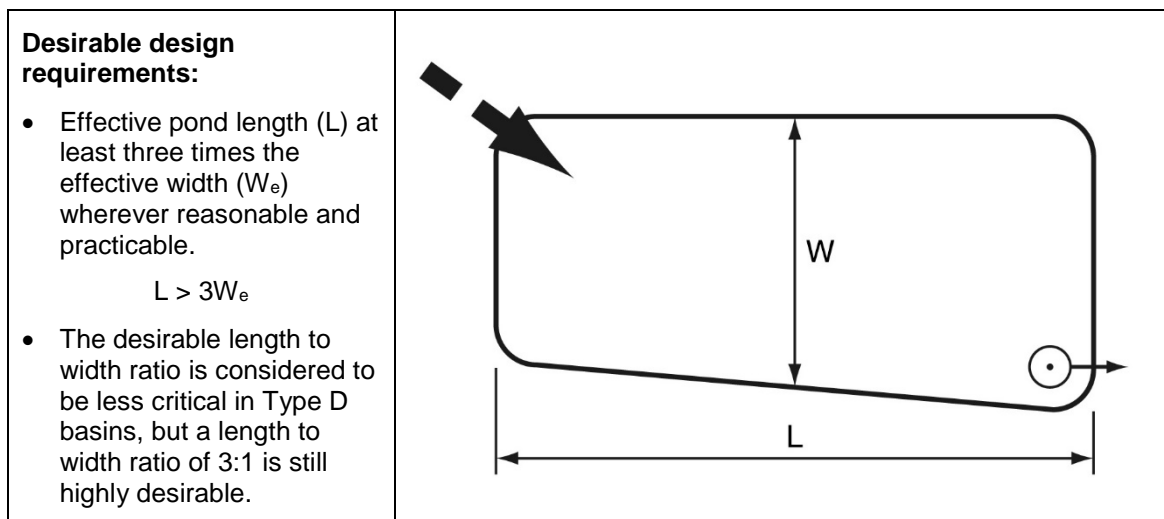

Figure B1 – Single sediment basin

The double basin shown in Figure B2 makes use of a narrow (say less than 5 m width) pre-treatment forebay that can be de-silted on a regular basis at low cost. The main settling pond has a surface area equivalent to a Type C basin independent of whether the basin is operated as a Type C or D basin. Type A & B basins make additional use of these forebays by using them to produce uniform inflow conditions to improve the basin's hydraulic efficiency.

If a Type D basin is required, then the combined settling volumes ($V_1 + V_2$) must satisfy that required for a Type D basin. In the case of Type A basins, the forebay volume cannot be included in the settling pond design because it is not free draining.

Discussion on the location of sediment basins and other sediment control devices adjacent to waterways is presented in Appendix I – *Instream works*.

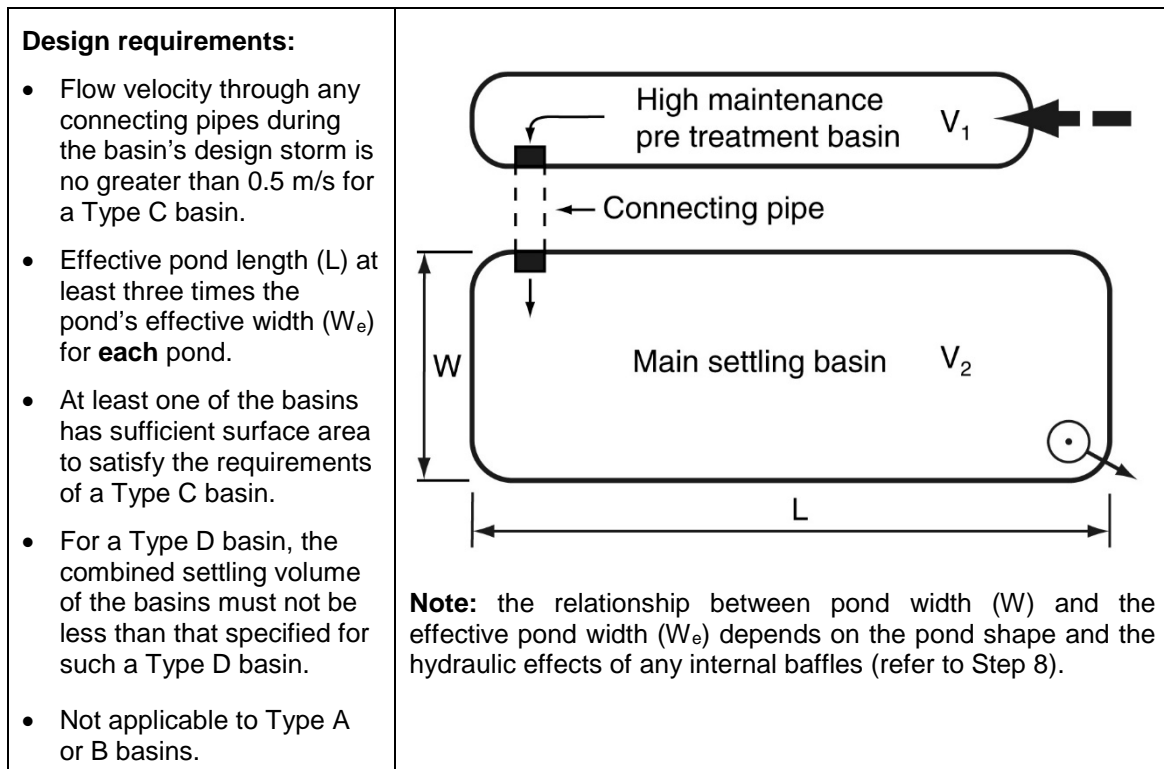

Figure B2 – Multiple sediment basins with single connecting pipe/culvert

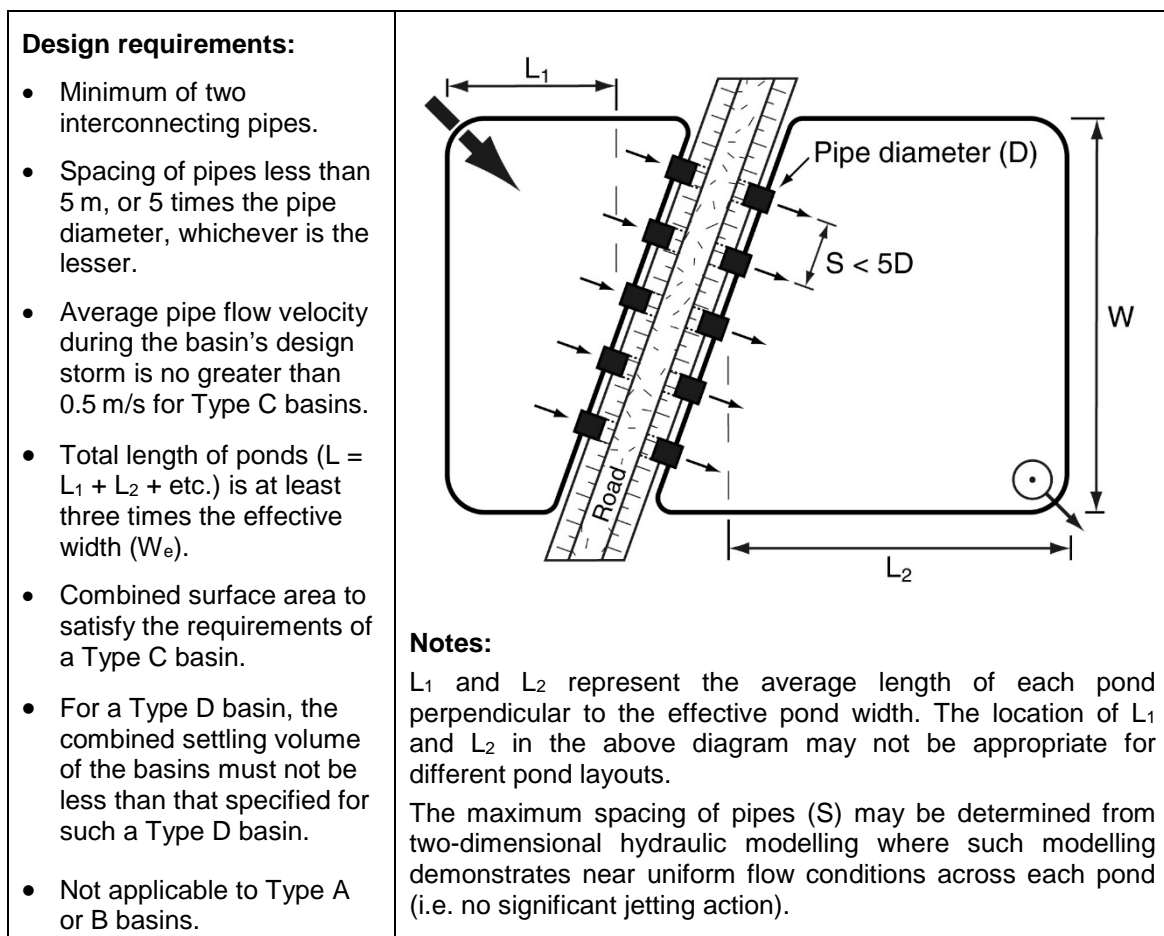

Figure B3 – Multiple sediment basins with multiple connecting pipes

Step 4: Divert up-slope 'clean' water

Wherever reasonable and practicable, up-slope 'clean' water should be diverted around the sediment basin to decrease the size and cost of the basin, and increase its efficiency. If flow diversion systems are used to divert clean water around the basin, then these systems will usually need to be modified as new areas of land are first disturbed, then stabilised.

'Clean' water is defined as water that either enters the property from an external source and has not been further contaminated by sediment within the property; or water that has originated from the site and is of such quality that it either does not need to be treated in order to achieve the required water quality standard, or would not be further improved if it was to pass through the type of sediment trap specified for the sub-catchment.

The *intent* is to minimise the volume of uncontaminated water flowing to a basin at any given time during the operation of the basin, even if the basin has been sized for the full catchment area.

Discussion:

One of the primary goals of an effective erosion and sediment control program is to divert external run-on water and any uncontaminated site water around major sediment control devices such as a sediment basin as demonstrated in Figure B4.

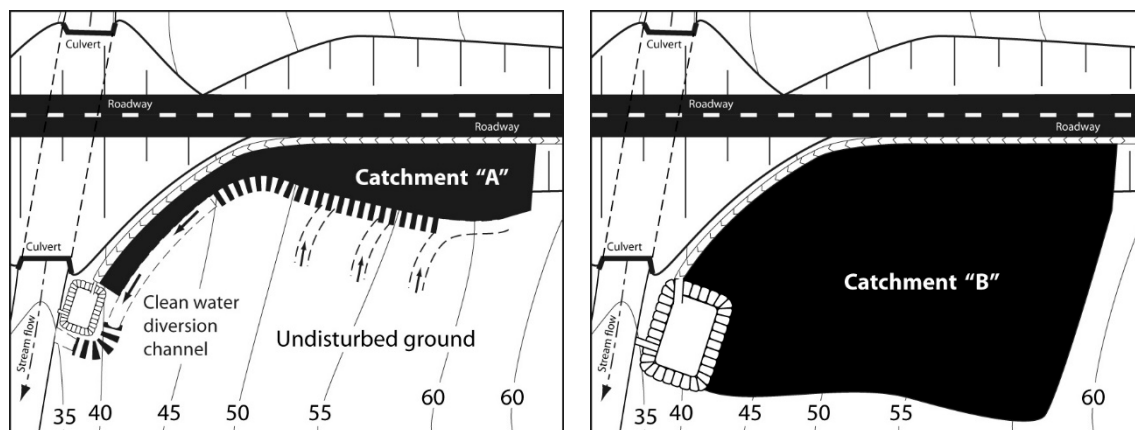

(a) Up-slope 'clean' water diverted around the sediment basin

(b) Up-slope 'clean' water not diverted around the sediment basin

Figure B4 – Beneficial effects of diverting 'clean' water around a basin

The effective catchment area may vary significantly during the construction phase as areas of disturbance are first connected to a sediment basin, then taken off-line as site rehabilitation occurs. It is considered best practice to prepare a Construction Drainage Plan (CDP) for each stage of earth works.

Step 5: Select internal and external bank gradients

It is usually necessary to determine the internal bank gradients of sediment basins before sizing the basin because this bank gradient can alter the mathematical relationship between pond surface area and volume.

Recommended bank gradients are provided in Table B4.

Table B4 – Suggested bank slopes

Slope (V:H)	Bank/soil description
1:2	Good, erosion-resistant clay or clay-loam soils
1:3	Sandy-loam soil
1:4	Sandy soils
1:5	Unfenced sediment basins that is accessible to the public
1:6	Mowable, grassed banks.

In circumstances where the failure of the basin wall has significant consequences for life and/or property, then all earth embankments in excess of 1 m in height should be certified by a geotechnical engineer/specialist.

If public safety is a concern, and the basin's internal banks are steeper than 1:5 (V:H), and the basin will not be fenced, then a suitable method of egress during wet weather needs to be installed. Examples include a ladder, steps cut into the bank, or at least one bank turfed for a width of at least 2 m from the top of bank to the toe of bank.

Step 6a: Sizing Type A basins

The settling pond within a Type A sediment basin is divided horizontally into three zones: an upper settling zone, a free water zone, and a sediment storage zone as shown in Figure B5.

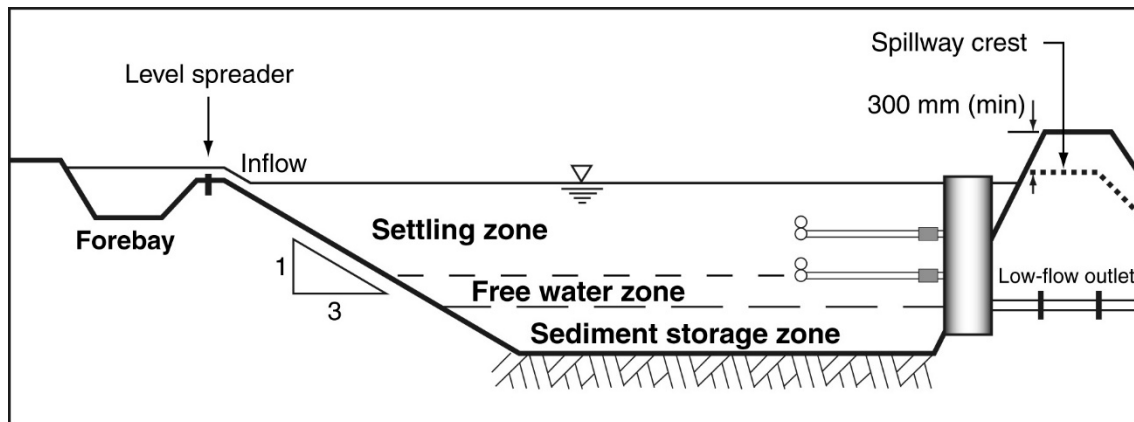

Figure B5 – Long-section of a typical Type A basin

The sizing of a Type A basin is governed by the requirements for both a minimum settling volume (V_s), and a minimum settling zone surface area (A_s). Under normal circumstances, a basin designer likely try to optimise the basin's dimensions such that both the pond volume and surface area are minimised, but site conditions can sometimes mean that one of these variables will dominate.

For a given low-flow decant rate (Q_A), there is an 'optimum' settling zone depth (D_s) that will allow the minimum settling volume and minimum settling zone surface area requirements to be achieved concurrently. Conversely, for a given settling zone depth, there is an 'optimum' low-flow decant rate that will also allow both of these design requirements to be achieved concurrently.

If site conditions place restrictions on the total depth of the sediment basin (D_T), then this will directly impact upon the maximum allowable depth of the settling zone (D_s); however, the relationship between the settling zone depth and the total pond depth is complex, and depends on a number of factors.

(i) Optimum low-flow decant rate:

If it is possible to determine, or nominate, a desirable settling zone depth (D_s), then the optimum low-flow decant rate may be determined from Equation B1.

$$Q_{A \text{ (optimum)}} = (K \cdot I^{1.8}) / (K_s \cdot D_s) \quad (\text{B1})$$

where:

- Q_A = the low-flow decant rate per hectare of contributing catchment [$\text{m}^3/\text{s}/\text{ha}$]
- K = equation coefficient that varies with the design event (X) and the low-flow decant rate (Q_A) refer to Table B8
- I = $I_{X \text{ yr}, 24 \text{ hr}}$ the average rainfall intensity for an X -year, 24-hour storm [mm/hr]
- K_s = inverse of the settling velocity of the critical particle size (Table B9)
- D_s = depth of the settling zone measured from the spillway crest [m]

For a 1 year ARI design event, the coefficient 'K' may be estimated from Equation B2:

$$K = 0.6836 Q_A^{-0.6747} \quad (B2)$$

This means the optimum low-flow decant rate can be estimated from Equation B3.

$$\text{For a 1 yr ARI design: } Q_{A(\text{optimum})} = 0.8 (I^{1.08}) / (K_A \cdot D_S)^{0.6} \quad (B3)$$

However, it is currently recommended that the low-flow decant rate should be limited to a maximum of 0.009 m³/s/ha (9 L/s/ha) to avoid settled sediment being drawn (lifted) towards the low-flow decant system, causing a decant water quality failure. It is this maximum low-flow decant rate that will govern the design in most parts of northern Australia. Recommend trial values of the low-flow decant rate (Q_A) are presented in Table B5 for various locations.

Table B5 – Suggested ‘trial value’ of the optimum low-flow decant rate, Q_A

Likely optimum Q_A	Locations
4 L/s/ha	Mildura, Adelaide, Mt Gambier ($D_S = 1.0$ to 1.5 m)
5 L/s/ha	Wagga, Melbourne, Bendigo, Ballarat, Hobart ($D_S = 1.0$ m) Bourke, Dubbo, Bathurst, Goulburn ($D_S = 1.5$ m)
6 L/s/ha	Bourke, Bathurst, Canberra, Perth ($D_S = 1.0$ m) Toowoomba (based on $D_S = 2.0$ m)
7 L/s/ha	Dubbo, Tamworth, Goulburn (based on $D_S = 1.0$ m) Roma, Toowoomba (based on $D_S = 1.5$ m)
8 L/s/ha	Dalby, Roma, Armidale (based on $D_S = 1.0$ m)
9 L/s/ha	Darwin, Cairns, Townsville, Mackay, Rockhampton, Emerald, Caloundra, Brisbane, Toowoomba ($D_S = 1.0$ m), Lismore, Port Macquarie, Newcastle, Sydney, Nowra

(ii) Optimum settling pond depth:

Alternatively, the designer may choose to nominate a low-flow decant rate (Q_A) based on the desired number of riser pipes and floating decant arms (refer to Figure B29), and then determine an optimum settling pond depth (D_S).

$$\text{For all ARI events: } D_{S(\text{optimum})} = (K \cdot I^{1.8}) / (K_S \cdot Q_A) \quad (B4)$$

$$\text{For a 1 yr ARI design: } D_{S(\text{optimum})} = 0.684 (I^{1.8}) / (K_S \cdot Q_A^{1.67}) \quad (B5)$$

For the Auckland-type decant system:

$$Q_A = 0.0045(\text{number of decant arms}) / (\text{catchment area}) \text{ [m}^3\text{/s/ha]}$$

The total basin depth (D_T) is made-up of various water layers as described in Table B6.

Table B6 – Components of the settling pond depth and volume (Type A basin)

Component		Term	Minimum depth	Term	Min. volume as a percentage of V_S	
Total depth	Settling zone	D_S	0.6 m	V_S	100%	
	Retained water zone	Free water	D_{FW}	0.2 m	V_F	—
		Sediment storage zone	D_{SS}	0.2 m	V_{SS}	30%

(iii) Design event:

The recommended design storm varies with the type of soil disturbance. It should be noted that nominating a particular design storm does not necessarily guarantee that the sediment basin will achieve the desirable performance outcomes during all storms up to that recurrence interval. The design event is used as a 'nominal' design variable, not a performance standard. Recommended design storms are provided in Table B7.

Table B7 – Recommended design storm for Type A basins

Design storm	Type of soil disturbance
1 yr	<ul style="list-style-type: none"> Short-term soil disturbances, such as civil construction and urban development.
5 yr	<ul style="list-style-type: none"> Long-term soil disturbances, such as landfill sites, quarries and mine sites.

(iv) Minimum settling zone volume, V_s :

The minimum settling volume shall be determined from the following equation:

$$V_s = K \cdot A (I_{X \text{ yr, 24 hr}})^{1.8} \quad (\text{B6})$$

where:

V_s = minimum settling volume [m³]

K = equation coefficient that varies with the design event (X) and the chosen low-flow decant rate (Q_A) refer to Table B8

A = area of the drainage catchment connected to the sediment basin [ha]

$I_{X \text{ yr, 24 hr}}$ = average rainfall intensity for an X -year, 24-hour storm [mm/hr]

X = the nominated design event (ARI) expressed in 'years' (Table B7)

Table B8 – Type A basin sizing equation coefficient 'K'

Low-flow decant rate ' Q_A '		Coefficient ' K ' for specific design events		
L/s/ha	m ³ /s/ha	1 year	2 year	5 year
2	0.002	45.0	46.0	46.9
3	0.003	34.5	36.7	39.5
4	0.004	28.4	30.8	33.9
6	0.006	22.7	22.9	26.0
8	0.008	17.6	18.8	20.9
9	0.009	16.2	17.4	19.3

For low-flow decants outside of the range of 2 to 9 L/s/ha, the value of the equation coefficient (K) can be estimated using the following equations; however, precedence must always be given to the values presented in Table B8.

$$X = 1 \text{ year ARI: } K = 0.684 Q_A^{-0.675} \quad (\text{B7})$$

$$X = 2 \text{ year ARI: } K = 0.784 Q_A^{-0.660} \quad (\text{B8})$$

$$X = 5 \text{ year ARI: } K = 1.159 Q_A^{-0.604} \quad (\text{B9})$$

(v) Minimum settling zone surface area requirement, A_s :

The minimum, average, surface area of the **settling zone** (A_s) is provided by Equation B10.

$$A_s = K_s Q_L \quad (\text{B10})$$

where: A_s = minimum, average, surface area of the settling zone [m^2]

K_s = sediment settlement coefficient = inverse of the settling velocity of the critical particle size [s/m]

Q_L = the maximum low-flow decant rate prior to flows overtopping the emergency spillway = $Q_A * A$ [m^3/s]

Q_A = the low-flow decant rate per hectare of contributing catchment [$\text{m}^3/\text{s/ha}$]

A = area of the drainage catchment connected to the basin [ha]

Based on the results of *Jar Testing*, as per Section B3(v), select an appropriate value of ' K_s '. from Table B9. If Jar Test results are not available, then choose $K_s = 12,000$.

Table B9 – Assessment of a design coefficient (K_s) from Jar Test results

Jar test settlement after 15 min (mm)	50	75	100	150	200	300
Laboratory settlement rate (m/hr)	0.20	0.30	0.40	0.60	0.80	1.20
Factor of safety	1.33	1.33	1.33	1.33	1.33	1.33
Design settlement rate, v_F (m/hr)	0.15	0.23	0.30	0.45	0.60	0.90
Design settlement coefficient, K_s (s/m)	24000	16000	12000	8000	6000	4000
Minimum depth of the settling zone:						
Minimum settling zone depth, D_s (m)	0.6	0.6	0.6	0.68	0.90	1.35

Typical water temperatures for capital cities are provided in Table B10. The water temperature within the settling pond is likely to be equal to the temperature of rainwater (approximately the air temperature during rainfall) at the time of year when rainfall intensity is the highest.

Table B10 – Recommended water temperature for use in performing a Jar Test

City	Suggested water temperature ($^{\circ}\text{C}$)
Darwin	30
Brisbane	20
Adelaide	15
Perth	15
Sydney	15
Canberra	10
Melbourne	10
Hobart	10

Design procedure for sizing a Type A sediment basin:

Step 1A: Determine the design event from Table B7.

Step 2A: **Select a trial low-flow decant rate (Q_A)** from Table B5.

Alternatively, use equations B1 or B3 to determine an optimum decant rate. This is the low-flow decant rate at maximum water level, i.e. when all decant arms (if multiple arms used) are operational.

A maximum decant rate of 9 L/s/ha is currently recommended until further field testing demonstrates that higher rates will not cause scour (lifting) of the settled sediment.

Step 3A: **Determine the optimum settling pond depth** using either equations B4 or B5.

Step 4A: **Choose a ‘design’ settling zone depth (D_S).**

To size a sediment basin such that it has the least volume and surface area, choose a settling zone depth equal to the optimum depth determined in Step 3A; however, a minimum depth of 0.6 m is recommended.

A minimum settling zone depth of 0.6 m is recommended because it:

- ensures a pond residence time in the order of 1.5 hours at the peak low-flow decant rate; and
- it reduces the risk of settled sediment being drawn up towards the floating decant arms.

Tables B13 to B15 can be used to estimate an appropriate settling zone depth (D_S) based on a desirable maximum basin depth (D_T), and a bank slope of 1 in 2 (excluding the inlet bank slope of 1 in 3).

If a greater settling zone depth is chosen, then the minimum surface area requirement will dominate, which will prevent the basin from being made smaller; however, the increased volume should improve the basin's overall treatment efficiency. A maximum settling zone depth of 2.0 m is recommended.

If a shallower settling zone depth is chosen, then the required minimum settling zone volume will dictate the basin's design, and the basin will have a surface area greater than that required by Step 5A. A settling zone depth less than 0.6 m is not recommended.

Step 5A: **Calculate the minimum, average, settling zone surface area (A_S)** based on Equation B10 and the following design conditions:

- (i) the expected settling rate of the treated sediment floc
- (ii) the expected water temperature within the pond during its critical operational phase (i.e. the local wet/rainy season).

It is noted that the water temperature influences water viscosity and the settling rate of a floc. The temperature within the settling pond is likely to be equal to the temperature of rainwater at the time of critical basin operation. As air temperatures approach zero-degrees, the pond temperature will be dictated by the surrounding soil temperature.

The minimum settling zone surface area as generated by Equation B10 is referred to as the ‘average’ surface area, meaning that when multiplied by the settling zone depth, it will equal the settling zone volume (V_S). In most cases it can be assumed that this average surface area is the same as the

surface area at the mid-depth of the settling zone (A_{MS}); however, this is not always technically correct (however, differences are usually minor).

If a more accurately determination of volume is required, then the Simpson's Rule can be used (Equation B11).

$$V_S = (D_S/6).(A_C + 4.A_{MS} + A_B) \quad (B11)$$

Step 6A: Calculate the required settling zone volume (V_S), being the greater of:

- (i) the minimum volume based on Equation B6
- (ii) the settling zone volume determined from the minimum average surface area obtained from Step 5A.

Step 7A: Nominate the depth (D_F) of the free water zone.

The free water zone is used to separate the settled sediment from the low-flow decant system to prevent settled sediment from being drawn into the decant system at the start of the next storm.

The free water zone is required to be at least 0.2 m in depth.

Step 8A: Check for the potential re-suspension.

The maximum allowable supernatant (clear liquor) velocity upstream of the overflow spillway has been set at 1.5 cm/s (0.015 m/s) based on decant testing of settled sludge blankets in wastewater treatment plants. Future field testing of Type A sediment basins may alter this value.

This means that a minimum free water depth of 0.2 m (refer to Table B6) is recommended for the Auckland-type, low-flow decant system, which has a decant rate of 2.25 L/s/m (i.e. 4.5 L/s through a 2 m wide arm).

Designers should also check that at the maximum decant rate (i.e. when all the decant arms are active) the average velocity of the clear supernatant above the settled sediment blanket (assumed to be around 0.6 m below the water surface) does not exceed 1.5 cm/s.

If a multi-arm decant system is used, then this velocity check should be performed for each increase in the decant rate.

Step 9A: Determine the length and width of the settling zone.

General requirement: settling zone length (L_C) > 3 times its width (W_C).

It is recommended that the length of the settling zone at the elevation of the spillway crest (i.e. at near maximum water level) should be at least three times the width of the settling zone at the elevation of the spillway crest.

For simplicity, designers may choose to set the length of the settling zone at the mid-elevation of the settling zone as equal to three times the mid-elevation width, then determine all other dimensions from these values.

Step 10A: Determine the remaining dimensions of the sediment basin.

Once the volume and dimensions of the settling zone are known, the remaining basin dimensions need to be determined based on the sizing requirements outlined in Table B6.

It is recommended that the bank slope of the inflow batter (adjacent the forebay) is 1 in 3 (refer to Figure B6).

Technical notes B2 to B4 outline a manual method for the determination of the minimum depth of the sediment storage zone (D_{SS}).

Technical Note B2 – Determination of basin dimensions given V_s and D_s

The initial design steps for a Type A basin result in the determination of two key parameters:

- the settling zone volume, V_s (m^3)
- the settling zone depth, D_s (m)

The settling zone volume (V_s) is taken as the greater of:

- the minimum settling zone volume determined from Equation B6; or
- the settling zone volume based on the minimum average settling zone surface area (A_s). This condition would dictate the settling zone volume in cases where the basin's design is controlled by the minimum surface area requirement presented by Equation B10.

The next step is to determine the depth of the basin (D_T), the bank slope (m), and the basin's width and length. Once the bank slope and base dimensions are known, all other dimensions can be determined (the following analysis assumes the slope of the inlet bank is 1 in 3).

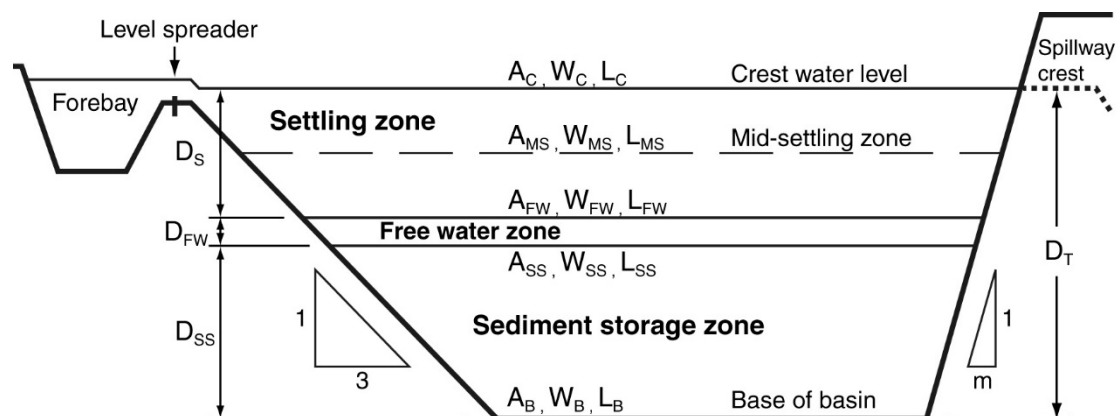

Figure B6 – Basin long-section with suggested dimensional terminology

If the parameters, V_s & D_s are known, then the basin's total depth (D_T) can be determined by one of the following methods:

- trial and error analysis of the basin's dimensions in order to achieve the various dimensional requirements of a Type A basin, including those outlined in Table B6
- utilisation of a spreadsheet program to determine suitable basin dimensions
- utilisation of the equations listed below to determine an 'approximation' of the sediment storage depth (D_{SS}) and total depth (D_T) based on the basin taking the shape of a trapezoidal prism.

Approximation of sediment storage depth (D_{SS}) and the total basin depth (D_T):

$$D_s/D_{SS} = K_1 \cdot \log_{10}(V_s - K_2) + K_3 \quad (\text{for values of } K_1, K_2, K_3 \text{ see Note B3}) \quad (\text{B12})$$

$$D_T = D_s + 0.2 + D_{SS} \quad (\text{B13})$$

Determination of the basin's length and width:

The basin's length and width is typically defined by its dimensions at the crest of the overflow weir (W_C & L_C); however, the basin's average surface area (A_s) is defined at the mid-elevation of the settling zone. It is recommended that basins are designed with a length:width = 3:1 at the elevation of the spillway crest; however, to simplify the design process, designers can choose to apply this recommended length:width ratio to the basin's dimensions at the mid-elevation of the settling zone, thus:

$$W_{MS} = (A_s/3)^{0.5} \quad (\text{B14})$$

$$L_{MS} = 3 \cdot W_{MS} \quad (\text{B15})$$

$$H_{MS} = 0.5D_s + 0.2 + D_{SS} \quad (\text{B16})$$

Technical Note B3 – Determination of equation coefficients

An approximation of sediment storage depth (D_{SS}) can be determined from Equation B17:

$$D_s/D_{SS} = K_1 \cdot \log_{10}(V_s - K_2) + K_3 \quad (\text{B17})$$

Values of the equation coefficients are provided in Table B11.

This equation is only an approximation, however, the resulting values of D_s/D_{SS} become increasingly questionable at low values of V_s when the base width of the basin approaches zero metres. In such cases, values of the sediment storage depth (D_{SS}) may be interpolated from the data provided in Technical Note B4 (Table B12).

Table B11 – Values of equation coefficients, K_1 , K_2 & K_3

Settling depth D_s (metres)	Bank slope m:1 (H:V)	Equation coefficients (equations B12 & B17)		
		K_1	$K_2 = V_{s1}$	K_3
0.6	1	0.9127	15	0.6945
0.6	1.5	0.8971	31	0.4859
0.6	2	0.8945	53	0.3082
0.6	3	0.8828	117	0.0656
0.6	4	0.8823	205	-0.1332
0.8	1	0.9164	31	0.4126
0.8	1.5	0.9029	64	0.2019
0.8	2	0.8912	111	0.0482
0.8	3	0.8834	244	-0.2021
0.8	4	0.8792	430	-0.3892
1	1	0.9127	56	0.2001
1	1.5	0.8974	116	-0.0019
1	2	0.8868	201	-0.1551
1	3	0.8793	442	-0.4036
1	4	0.8754	779	-0.5900
1.2	1	0.9150	91	0.0079
1.2	1.5	0.8948	190	-0.1771
1.2	2	0.8850	329	-0.3305
1.2	3	0.8754	726	-0.5695
1.2	4	0.8715	1280	-0.7542
1.5	1	0.9124	168	-0.2183
1.5	1.5	0.8902	352	-0.3911
1.5	2	0.8789	611	-0.5361
1.5	3	0.8694	1349	-0.7713
1.5	4	0.8652	2380	-0.9526

The above table provides typical values based on a rectangular basin with the inlet bank slope of 1 in 3, and all other banks having a gradient of 1 in 'm' (where values of 'm' are 1.0, 1.5, 2.0 & 3.0).

The term ' K_2 ' defines the minimum possible settling zone volume (V_{s1}) that can exist for given values of D_s & m at the point where the base width (W_B) approaches zero metres.

Technical Note B4 – Interpolation of basin dimensions for low values of 'Vs'

Low range values of V_s that can be used to interpolate an estimate of the sediment storage depth D_{SS} that achieves the minimum sediment storage volume, $V_{SS} = 0.3V_s$, are provided below.

Table B12 – Basin dimensions for low range values of V_s

D_s (m)	m (slope)	Minimum workable value				Low-range value			
		V_{S1} (m ³)	D_{SS} (m)	W_B (m)	L_B (m)	V_{S2} (m ³)	D_{SS} (m)	W_B (m)	L_B (m)
0.6	1	15	0.73	0	4.0	22	0.42	1.5	7.0
0.6	1.5	31	0.70	0	7.7	45	0.41	2.0	11.5
0.6	2	53	0.73	0	11.1	76	0.40	2.6	16.1
0.6	3	117	0.69	0	18.8	168	0.39	3.7	25.5
0.6	4	205	0.73	0	26.0	295	0.38	4.9	34.7
0.8	1	31	1.01	0	4.7	45	0.56	1.9	8.7
0.8	1.5	64	1.00	0	9.2	92	0.54	2.5	14.4
0.8	2	111	0.95	0	14.0	160	0.52	3.2	20.2
0.8	3	244	0.93	0	23.4	351	0.51	4.6	32.0
0.8	4	430	0.91	0	32.8	619	0.50	6.1	43.8
1	1	56	1.25	0	5.7	81	0.69	2.2	10.5
1	1.5	116	1.20	0	11.2	167	0.66	3.0	17.4
1	2	201	1.16	0	16.9	289	0.65	3.8	24.4
1	3	442	1.14	0	28.3	636	0.63	5.6	38.6
1	4	779	1.12	0	39.6	1122	0.62	7.3	52.9
1.2	1	91	1.54	0	6.3	131	0.83	2.6	12.2
1.2	1.5	190	1.45	0	13.0	274	0.79	3.5	20.3
1.2	2	329	1.40	0	19.7	474	0.77	4.5	28.6
1.2	3	726	1.35	0	33.2	1045	0.75	6.5	45.3
1.2	4	1280	1.33	0	46.5	1843	0.74	8.5	62.0
1.5	1	168	1.95	0	7.5	242	1.03	3.1	14.8
1.5	1.5	352	1.81	0	15.8	507	0.97	4.3	24.8
1.5	2	611	1.72	0	24.1	880	0.95	5.5	35.0
1.5	3	1349	1.67	0	40.5	1943	0.93	8.0	55.4
1.5	4	2380	1.65	0	56.9	3427	0.91	10.5	75.9

The term ' V_{S1} ' defines the minimum possible settling zone volume that can exist for given values of D_s , m , and $V_{SS} = 0.3V_s$ at the point where the base width (W_B) approaches zero metres.

The term ' V_{S2} ' defines a low-range value of the settling zone volume for which Equation B12 is considered to provide a suitable estimate of the term D_s/D_{SS} . Equation B12 can produce questionable values of D_s/D_{SS} for settling volumes between the values of V_{S1} and V_{S2} .

In some cases the basin's preferred dimensions will be governed by a desirable maximum total basin depth (D_T). In such cases, tables B13 to B15 can be used to interpolate typical values of D_s and D_{SS} for a basin with side slopes of 1 in 2.

Table B13 – Typical Type A settling zone, free water & sediment storage depths

Type A basin geometry with sediment storage volume, $V_{SS} = 30\%$ (V_S):						
Inlet bank slope, 1 in 3	All other bank slopes, 1 in 2			Total depth, $D_T = 1.5$ m		
Typical basin dimensions based on a length:width ratio of 3:1 at top of the settling zone:						
Settling zone volume, V_S [m ³]	50	100	200	400	800	1600
Total basin volume, V_T [m ³]	75	147	292	585	1176	2364
Settling zone surface area [m ²]	85	136	241	449	863	1682
Settling zone depth (D_S) [m]	0.59	0.73	0.83	0.89	0.93	0.95
Ratio D_S/D_T as a percentage	39%	49%	55%	60%	62%	64%
Free water depth (D_{FW}) [m]	0.20	0.20	0.20	0.20	0.20	0.20
Ratio D_{FW}/D_T as a percentage	13%	13%	13%	13%	13%	13%
Sediment storage (D_{SS}) [m]	0.71	0.57	0.47	0.41	0.37	0.35
Ratio D_{SS}/D_T as a percentage	48%	38%	32%	27%	25%	23%

* The settling zone surface area represents the 'average' surface area, $A_S = V_S/D_S$.

Table B14 – Typical Type A settling zone, free water & sediment storage depths

Type A basin geometry with sediment storage volume, $V_{SS} = 30\%$ (V_S):						
Inlet bank slope, 1 in 3	All other bank slopes, 1 in 2			Total depth, $D_T = 2.0$ m		
Typical basin dimensions based on a length:width ratio of 3:1 at top of the settling zone:						
Settling zone volume, V_S [m ³]	120	200	400	800	1600	3200
Total basin volume, V_T [m ³]	172	282	559	1119	2247	4514
Settling zone surface area [m ²]	143	202	351	648	1240	2412
Settling zone depth (D_S) [m]	0.83	0.98	1.13	1.23	1.29	1.32
Ratio D_S/D_T as a percentage	42%	49%	57%	61%	64%	66%
Free water depth (D_{FW}) [m]	0.20	0.20	0.20	0.20	0.20	0.20
Ratio D_{FW}/D_T as a percentage	10%	10%	10%	10%	10%	10%
Sediment storage (D_{SS}) [m]	0.97	0.82	0.67	0.57	0.51	0.48
Ratio D_{SS}/D_T as a percentage	48%	41%	33%	29%	26%	24%

Table B15 – Typical Type A settling zone, free water & sediment storage depths

Type A basin geometry with sediment storage volume, $V_{SS} = 30\%$ (V_S):						
Inlet bank slope, 1 in 3	All other bank slopes, 1 in 2			Total depth, $D_T = 3.0$ m		
Typical basin dimensions based on a length:width ratio of 3:1 at top of the settling zone:						
Settling zone volume, V_S [m ³]	400	800	1600	3200	6400	12,800
Total basin volume, V_T [m ³]	558	1075	2146	4302	8632	17310
Settling zone surface area [m ²]	305	488	867	1623	3124	6102
Settling zone depth (D_S) [m]	1.33	1.62	1.83	1.96	2.04	2.10
Ratio D_S/D_T as a percentage	44%	54%	61%	65%	68%	70%
Free water depth (D_{FW}) [m]	0.20	0.20	0.20	0.20	0.20	0.20
Ratio D_{FW}/D_T as a percentage	7%	7%	7%	7%	7%	7%
Sediment storage (D_{SS}) [m]	1.47	1.18	0.97	0.84	0.76	0.70
Ratio D_{SS}/D_T as a percentage	49%	39%	32%	28%	25%	23%

Step 6b: Sizing Type B basins

The settling pond within a Type B sediment basin is divided horizontally into two zones: the upper settling zone and the lower sediment storage zone as shown in Figure B7.

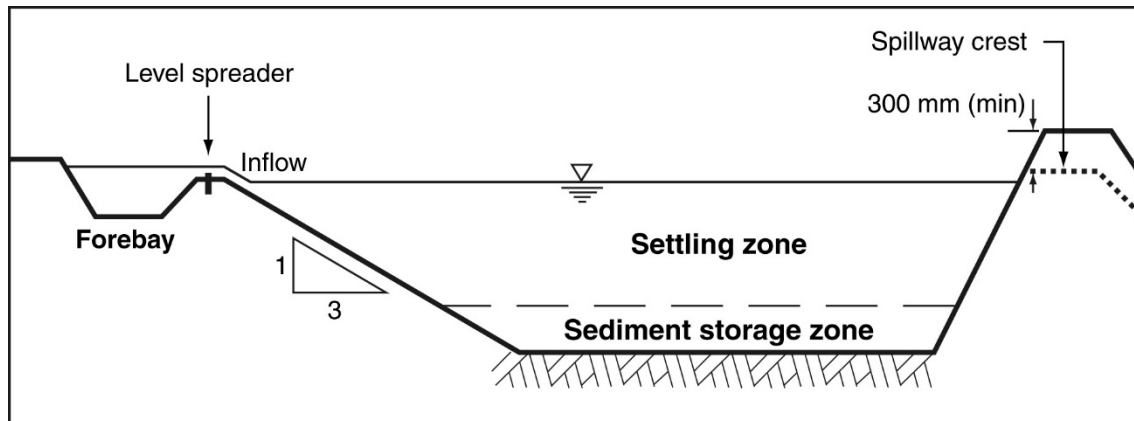

Figure B7 – Long-section of a typical Type B basin

Type B basins incorporate some features of the high-efficiency Type A basin, but these basins do not incorporate a low-flow decant system, and it is not considered mandatory during dry weather conditions for these basins to be de-watered immediately after the basins achieve a desirable water quality. This means valuable water captured by these basins during extended periods of infrequent storms can be utilised for on-site purposes. However, the penalty for being able to retain this water and for not having a low-flow decant system is that the basins are significantly larger than Type A basins.

Table B16 – Components of the settling pond depth and volume (Type B basin)

Component		Term	Minimum depth	Term	Min. volume as a percentage of V_s
Total depth	Settling zone	D_s	0.5 m Option 1B 0.6 m Option 2B	V_s	100%
	Sediment storage zone	D_{ss}	0.2 m	V_{ss}	30%

There are two design options for sizing Type B basins, as outlined below:

- (i) Option 1B is based on setting a minimum settling pond surface area (A_s) and depth (D_s) such that the settled sediment has sufficient settlement time to reach the existing settled sediment layer, which means the sediment floc is able to form a 'compact' sediment blanket. It is anticipated that such a sediment blanket would have a greater resistance to the effects of surface scour caused by the forward movement of the above supernatant layer.
- (ii) Option 2B is based on providing sufficient time to allow the sediment floc to settle at least 600 mm below the spillway crest, thus avoiding the risk of this suspended sediment floc being lifted towards the low-flow decant system. This design option allows for the design of basins with a greater depth, but smaller surface area than design option 1B.

There is a greater risk of sediment re-suspension in Option 2B because of the limited research into the hydraulic stability of decanting from a sediment basin while the sediment floc is in full suspension (i.e. still settling). Therefore, preference should be given to the adoption of Option 1B wherever possible.

Design procedure for a Type B, Option 1B:

Step 1B: Determine the design discharge, Q.

The design discharge may be governed by state, regional or local design standards; however, if such standards do not exist, then the recommended design storm is 0.5 times the peak 1 year ARI discharge.

$$Q = 0.5 Q_1 \quad (\text{B18})$$

where: Q_1 = peak discharge for the 1 in 1 year ARI design storm [m^3/s]

This peak design discharge should be based on the critical storm duration for the maximum drainage catchment likely to be connected to the basin.

Step 2B: Determine a design value for the sediment settlement coefficient (K_S)

The determination of the settling coefficient (K_S) should be based on the results of *Jar Testing* of the anticipated chemically treated sediment floc as per Section B3(v), select an appropriate value of ' K_S ' from Table B17.

If Jar Test results are not available, then choose $K_S = 12,000$.

Step 3B: Calculate the minimum required 'average' surface area (A_S) of the settling zone.

$$A_S = K_S Q \quad (\text{B19})$$

where: A_S = minimum, average, settling zone, surface area [m^2]

K_S = sediment settlement coefficient (Table B17)

= inverse of the settling velocity of the treated sediment blanket

Q = the design discharge = $0.5 Q_1$ [m^3/s]

Table B17 – Sediment settlement characteristics for design option 1B

Jar test settlement after 15 min (mm)	50	75	100	150	200	300
Laboratory settlement rate (m/hr)	0.20	0.30	0.40	0.60	0.80	1.20
Factor of safety	1.33	1.33	1.33	1.33	1.33	1.33
Design settlement rate, v_F (m/hr)	0.15	0.23	0.30	0.45	0.60	0.90
Design settlement coefficient, K_S (s/m)	24000	16000	12000	8000	6000	4000
Minimum depth of the settling zone:						
Minimum settling zone depth, D_S (m)	0.5	0.5	0.5	0.68	0.90	1.35
Critical settling zone length before Step 5B begins to dictate the basin size:						
Critical settling zone length (L_S) before Step 5B and Equation B21 begin to dictate the basin size (m)	180	120	90	81	81	81

Step 4B: Determine the minimum depth of the settling zone (D_S) from Table B17.

If the sediment-flocculant partnership results in a poor sediment settlement rate, such as less than 100 mm in 15 minutes, then the minimum depth of the settling zone (D_S) is governed by the minimum recommended depth of 0.5 m, which increases the volume of the settling zone compared to those basins that utilise an more effective flocculant.

Step 5B: Check for the potential re-suspension of the settled sediment.

A Type B basin does not incorporate a low-flow decant system, thus the spillway functions as the sole point of discharge during storm events.

To avoid the re-suspension of the settled sediment, the clear water (supernatant) flow velocity (v_c) should not exceed 0.015 m/s (1.5 cm/s).

$$v_c = Q / (D_s \cdot W_s) \quad [\text{m/s}] \quad (\text{B20})$$

where: v_c = flow velocity of the clear water supernatant [m/s]

D_s = depth of the settling zone [m]

W_s = average width of the settling zone [m]

For design option 1B, the supernatant velocity check outlined in Equation B20 will only become critical when the length of the settling zone (L_s) exceeds the critical value given by Equation B21 (also see Table B17).

$$L_{S(\text{critical})} = 0.015 \cdot K_s \cdot D_s \quad [\text{m}] \quad (\text{B21})$$

where: L_s = average length of the settling zone [m]

If a larger sediment basin is required, then the settling zone must be re-sized with Equation B20 dictating the basin size rather than Equation B19. Thus the settling zone surface area (A_s) determine in Step 3B will no longer be appropriate.

If the clear water supernatant velocity (v_c) is set at the maximum allowable value of 0.015 m/s, then Equation B20 can be rewritten as:

$$D_s \cdot W_s = 66.7(Q) \quad [\text{m}^2] \quad (\text{B22})$$

This means that either the depth (D_s) and/or the width (W_s) must be increased above the values obtained in Step 3B.

Increasing the depth (D_s) means increasing the basin volume, but not the surface area (A_s). Increasing the width (W_s) means increasing the basin volume, length (L_s) and surface area (A_s).

It is recommended that the width of the settling zone at the top water level (W_T) should not exceed a third of the length of the settling zone at the top water level (L_T).

Step 6B: Determine the width of the overflow spillway.

In order to reduce the risk of the re-suspension of settled sediment, the overflow spillway should have the maximum practical width.

Ideally the maximum allowable supernatant velocity upstream of the overflow spillway should be 1.5 cm/s (0.015 m/s) during the basin's design storm (i.e. $Q = 0.5 Q_1$); however, this may not always be practical. In such cases, designers should take all reasonable measures to achieve a spillway crest width just less than the top width of the settling zone.

Step 7B: Determine the remaining dimensions of the sediment basin.

Once the volume and dimensions of the settling zone are known, the remaining basin dimensions need to be determined based on the sizing requirements outlined in Table B16. Determining the depth of the sediment storage zone can be complex given the basin geometry; however, tables B19 to B21 can be used to estimate the storage depth.

Design procedure for a Type B, Option 2B:

Step 1B: Determine the design discharge, Q.

The design discharge may be governed by state, regional or local design standards; however, if such standards do not exist, then the recommended design storm is 0.5 times the peak 1 year ARI discharge.

$$Q = 0.5 Q_1 \quad (\text{B23})$$

where: Q_1 = peak discharge for the 1 in 1 year ARI design storm [m^3/s]

This peak design discharge should be based on the critical storm duration for the maximum drainage catchment likely to be connected to the basin.

Step 2B: Nominate the desired settling zone depth, D_s , and the floc settling depth, D_F .

D_F is the minimum depth that the sediment floc should settle before the floc reaches the outlet overflow weir. This depth should be at least 0.6 m.

$$D_F \geq 0.6 \quad (\text{B24})$$

The minimum settling zone depth is 0.6 m, which is an increase from the 0.5 m used in design option 1B. This is because in this design option the sediment floc is considered to be still settling as it approaches the overflow spillway, whereas in design option 1B the sediment floc is assumed to have fully settled, and thus more resistant to disturbance.

D_s is the effective depth of the settling zone (i.e. the maximum water depth above the sediment storage zone). Increasing this depth will reduce the forward velocity of the settling sediment floc, which increases the residence time and therefore the time available for the sediment floc to settling the required floc settling depth, D_F .

$$D_s \geq D_F \quad (\text{B25})$$

The nominated settling zone depth can be within the range of 0.6 to 2.0 m. The greater the nominated depth, the smaller the required surface area of the basin, but the volume of the settling zone (V_s), and consequently the total basin volume, will essentially remain unchanged.

Step 3B: Calculate the 'average' surface area (A_s) of the settling zone.

$$A_s = (D_F/D_s) K_s Q \quad (\text{B26})$$

where: A_s = minimum, average, settling zone, surface area [m^2]

K_s = sediment settlement coefficient (Table B18)

= inverse of the settling velocity of the treated sediment blanket

Q = the design discharge = $0.5 Q_1$ [m^3/s]

Table B18 – Sediment settlement characteristics for design option 2B

Jar test settlement after 15 min (mm)	50	75	100	150	200	300
Laboratory settlement rate (m/hr)	0.20	0.30	0.40	0.60	0.80	1.20
Factor of safety	1.33	1.33	1.33	1.33	1.33	1.33
Design settlement rate, v_F (m/hr)	0.15	0.23	0.30	0.45	0.60	0.90
Design settlement coefficient, K_s (s/m)	24000	16000	12000	8000	6000	4000

Step 4B: Check for the potential re-suspension of the settled sediment.

A Type B basin does not incorporate a low-flow decant system, and thus the overflow spillway functions as the sole point of discharge from the basin.

To avoid the re-suspension of the settling sediment floc, the clear water (supernatant) flow velocity (v_c) should not exceed 0.015 m/s (1.5 cm/s).

$$v_c = Q/(D_F \cdot W_{SF}) \text{ [m/s]} \quad (\text{B27})$$

where: v_c = flow velocity of the clear water supernatant [m/s]

D_F = depth of the settled sediment floc [m]

W_{SF} = average basin width of the clear water above the floc (i.e. measured over a depth of D_F , not D_S) [m]

This is the least understood operating condition of a Type B basin (option 2B), and there is currently no certainty that satisfying Equation B27 will always achieve optimum basin performance during high flows.

In order to satisfy Equation B27, the minimum average basin width (W_{SF}) can be determined from Equation B28.

$$W_{SF} = 66.7(Q/D_F) \text{ [m]} \quad (\text{B28})$$

Increasing the width of the settling zone (W_{SF}) can be problematic because it usually requires an increase the length of the settling zone (L_S).

In any case, the length of the settling zone (L_C) should ideally be at least three times the width of the settling zone (W_C) measured at the overflow weir crest elevation (Figure B6), thus:

$$L_C \geq 3 W_C \quad (\text{B29})$$

Step 5B: Determine the width of the overflow spillway.

In order to reduce the risk of the re-suspension of settled sediment as flows spill over the outlet weir, the width of the overflow spillway on Type B basins should be the maximum practical, and ideally at least equal to the average clear water width, W_{SF} .

Step 6B: Determine the remaining dimensions of the sediment basin.

Once the volume and dimensions of the settling zone are known, the remaining basin dimensions need to be determined based on the sizing requirements outlined in Table B16.

The minimum dimensions of a Type B basin must be based on concurrently satisfying the minimum average surface area (A_S), the minimum settling zone depth (D_S) or depth to the settled floc (D_F), and the maximum supernatant velocity (v_s) requirements.

Tables B19 to B21 provide typical Type B sediment basin dimensions for various 'average' settling zone surface areas based on a total basin depth (D_T) of 1, 2 and 3 m, for basins with side slopes of 1 in 2 (i.e. $m = 2$).

Table B19 – Typical Type B settling zone and sediment storage depths

Type B basin geometry with sediment storage volume = 30% (V_s):						
Inlet bank slope, 1 in 3	All other bank slopes, 1 in 2			Total depth, $D_T = 1.0$ m		
Typical basin dimensions based on a length:width ratio of 3:1 at top of the settling zone:						
Settling zone surface area [m^2]	36	50	100	200	400	800
Settling zone volume, V_s [m^3]	18	29	65	139	288	589
Total basin volume, V_T [m^3]	24	37	84	180	374	765
Settling zone depth (D_s) [m]	0.50	0.56	0.65	0.69	0.72	0.74
Ratio D_s/D_T as a percentage	50%	56%	65%	69%	72%	74%
Sediment storage (D_{ss}) [m]	0.50	0.44	0.35	0.31	0.28	0.26
Ratio D_{ss}/D_T as a percentage	50%	44%	35%	31%	28%	26%
Top length of settling zone [m]	12.6	14.7	20.1	27.5	37.7	52.1
Top width of settling zone [m]	4.2	4.9	6.7	9.2	12.6	17.4

* The settling zone surface area represents the 'average' surface area, $A_s = V_s/D_s$.

Table B20 – Typical Type B settling zone and sediment storage depths

Type B basin geometry with sediment storage volume = 30% (V_s):						
Inlet bank slope, 1 in 3	All other bank slopes, 1 in 2			Total depth, $D_T = 2.0$ m		
Typical basin dimensions based on a length:width ratio of 3:1 at top of the settling zone:						
Settling zone surface area [m^2]	150	300	600	1200	2400	4800
Settling zone volume, V_s [m^3]	154	373	815	1705	3506	7131
Total basin volume, V_T [m^3]	200	484	1058	2215	4553	9262
Settling zone depth (D_s) [m]	1.02	1.23	1.35	1.42	1.46	1.48
Ratio D_s/D_T as a percentage	51%	62%	68%	71%	73%	74%
Sediment storage (D_{ss}) [m]	0.98	0.77	0.65	0.58	0.54	0.52
Ratio D_{ss}/D_T as a percentage	49%	38%	32%	29%	27%	26%
Top length of settling zone [m]	25.6	35.3	48.2	66.1	91.1	126
Top width of settling zone [m]	8.5	11.8	16.1	22.0	30.4	42.1

Table B21 – Typical Type B settling zone and sediment storage depths

Type B basin geometry with sediment storage volume = 30% (V_s):						
Inlet bank slope, 1 in 3	All other bank slopes, 1 in 2			Total depth, $D_T = 3.0$ m		
Typical basin dimensions based on a length:width ratio of 3:1 at top of the settling zone:						
Settling zone surface area [m^2]	300	600	1200	2400	4800	9600
Settling zone volume, V_s [m^3]	438	1094	2416	5086	10475	21343
Total basin volume, V_T [m^3]	569	1421	3138	6605	13605	27720
Settling zone depth (D_s) [m]	1.44	1.81	2.00	2.11	2.18	2.22
Ratio D_s/D_T as a percentage	48%	60%	67%	70%	73%	74%
Sediment storage (D_{ss}) [m]	1.56	1.19	1.00	0.89	0.82	0.78
Ratio D_{ss}/D_T as a percentage	52%	40%	33%	30%	27%	26%
Top length of settling zone [m]	36.2	50.2	68.6	93.9	129	179
Top width of settling zone [m]	12.1	16.7	22.9	31.3	43.1	59.7

Step 6c: Sizing Type C basins

The settling pond within a Type C sediment basin is divided horizontally into two zones: the upper *settling zone* and the lower *sediment storage zone* as shown in Figure B8.

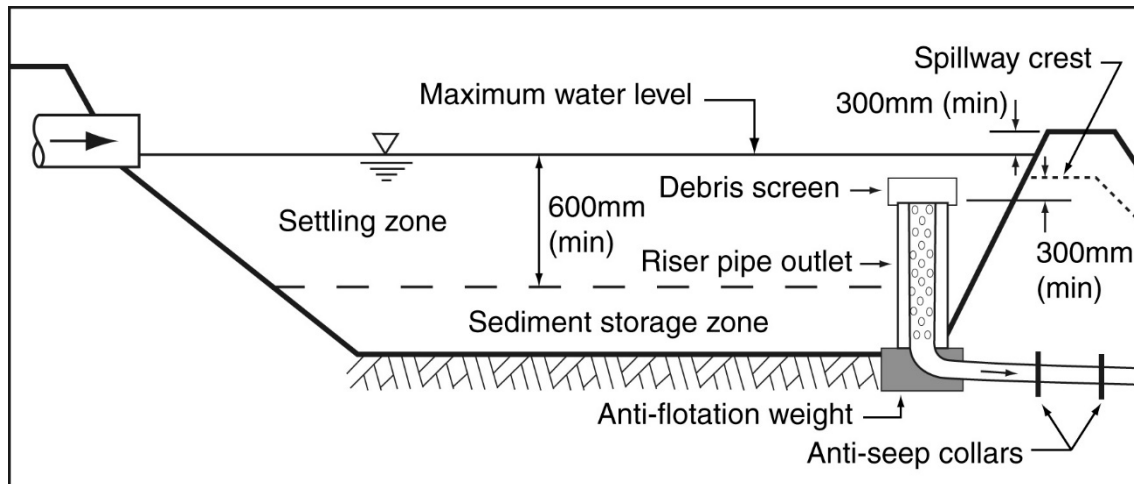

Figure B8 – Type C sediment basin with riser pipe outlet (long-section)

The minimum 'average' surface area of the settling zone (A_s) is given by Equation B30.

$$A_s = K_s H_e Q \quad (\text{B30})$$

- where:
- A_s = average surface area of settling zone = V_s/D_s [m^2]
 - K_s = sediment settlement coefficient = the inverse of the settling velocity of the 'critical' particle size (Table B22)
 - H_e = hydraulic efficiency correction factor (Table B23)
 - Q = design discharge = $0.5 Q_1$ [m^3/s]
 - Q_1 = peak discharge for the critical storm duration 1 in 1 year ARI event
 - V_s = volume of the settling zone [m^3]
 - D_s = depth of the settling zone [m]

Unless otherwise required by a regulatory authority, the design flow rate (Q) for a Type-C sediment basin should be 0.5 times the peak 1 in 1 year ARI discharge (Q_1).

Table B22 provides values for the sediment settlement coefficient (K_s) for a 'critical' particle size, $d = 0.02$ mm (0.00002 m), and various water temperatures and sediment specific gravities (s). The derivation of the coefficient is provided in Technical Note B5. If the critical particle size is not defined, then it may be set equal to the grain size of which 70% of the sediment is larger (i.e. d_{30}).

The hydraulic efficiency correction factor (H_e) depends on flow conditions entering the basin, and the shape of the settling pond. Table B23 provides recommended values of the hydraulic efficiency correction factor.

The minimum recommended depth of the settling zone (D_s) is 0.6 m. The desirable minimum length to width ratio at the mid-elevation of the settling zone is 3:1. Internal baffles may be required in order to prevent short-circuiting if the length-to-width ratio is less than three (refer to design Step 8).

Table B25 to B27 provide Type C basin typical dimension for a bank slope of 1 in 2.

Table B22 – Sediment settlement coefficient (K_s)

Water temperature (degrees C)	5	10	15	20	25	30
Kinematic viscosity ($m^2/s \times 10^6$)	1.519	1.306	1.139	1.003	0.893	0.800
Critical particle characteristics	Sediment settlement coefficient (K_s)					
d = 0.02 mm and s = 2.2	5810	4990	4350	3830	3410	3060
d = 0.02 mm and s = 2.4	4980	4280	3730	3290	2930	2620
d = 0.02 mm and s = 2.6 (default)	4360	3740	3270	2880	2560	2290
d = 0.02 mm and s = 2.8	3870	3330	2900	2560	2280	2040
d = 0.02 mm and s = 3.0	3480	3000	2610	2300	2050	1840
d = 0.02 mm and s = 3.2	3170	2720	2380	2090	1860	1670

Table B23 – Hydraulic efficiency correction factor (H_e)

Flow condition within basin	Effective ^[1] length:width	H_e
Uniform or near-uniform flow conditions across the full width of basin. ^[2] For basins with concentrated inflow, uniform flow conditions may be achieved through the use of an appropriate inlet chamber arrangement (refer to Step 9).	1:1	1.2
	3:1	1.0
Concentrated inflow (piped or overland flow), primarily at one inflow point, and no inlet chamber to evenly distribute flow across the full width of the basin.	1:1	1.5
	3:1	1.2
	6:1	1.1
	10:1	1.0
Concentrated inflow with two or more separate inflow points, and no inlet chamber to evenly distribute flow across the full width of the basin.	1:1	1.2
	3:1	1.1

Notes:

- [1] The effective length to width ratio for sediment basins with internal baffles (Step 8, Figure B12) is measured along the centreline of the dominant flow path.
- [2] Uniform flow conditions may also be achieved in a variety of ways including through the use of an inlet chamber and internal flow control baffles (refer to steps 8 & 9).

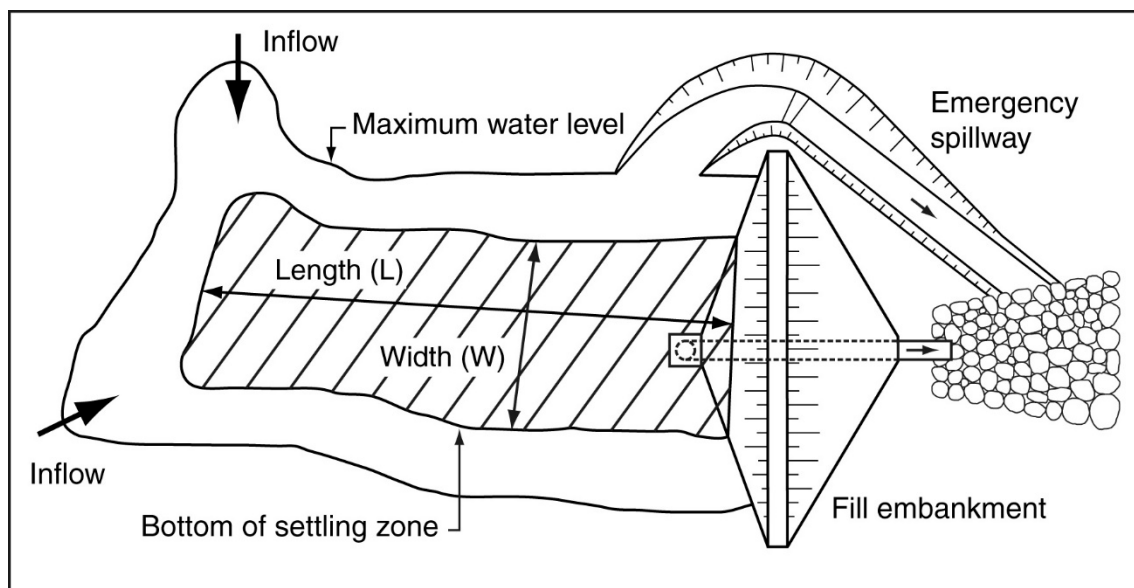
**Figure B9 – Type C sediment basin with riser pipe outlet (plan view)**

Technical Note B5 – Derivation of Type C basin sizing formula

Consider a rectangular sediment basin with uniform inflow (Q), width (W), depth (D) and length (L):

- the average forward velocity: $V_H = Q/(D.W)$
- the travel time across the basin: $t_H = L/(V_H)$
- thus, $t_H = (L.D.W)/Q = \text{Volume/Discharge}$
- in other words, $t_H = \text{retention time}$

The assumption of 'uniform flow' means that the hydraulic efficiency correction factor, $H_e = 1.0$.

The falling velocity of a particle may be determined from Stokes' Law; thus the falling velocity depends on:

- particle size, shape and relative density
- water temperature (a factor of viscosity) assumed to be based on temperature of rainfall
- water motion (turbulence and up-flow caused by mass settlement of sediment particles)
- electro-magnetic forces (not considered in the Stokes' Law equation).

Stokes' Law is presented as:

$$v_p = (g.(s-1).d^2)/(18.\mu) = 1/K_A \quad (\text{B31})$$

where: v_p = particle settling velocity [m/s]
 s = specific gravity of particle
 g = acceleration due to gravity [m/s²]
 d = particle diameter [m]
 μ = kinematic viscosity of the water at a given temperature [m²/s]

Particle settling velocities are presented in Table B24 for a specific gravity of 2.6:

Table B24 – Particle settling velocity (mm/s) for different water temperatures

Diameter (mm)	10° C	15° C	20° C
0.01	0.07	0.08	0.09
0.02	0.27	0.31	0.35
0.05	1.67	1.91	2.17
0.10	6.67	7.65	8.69

If the sediment basin is sized such that the critical particle size settles to the bed (t_p) just before reaching the end of the basin, then:

$$t_H = t_p$$

or

$$t_H = (L.D.W.)/Q = D/v_p$$

thus

$$\text{Surface Area } (A_s) = L.W = Q/v_p \quad (\text{B32})$$

So for a soil with critical particle size of 0.02 mm, and specific gravity of 2.6, and with a basin water temperature of 13° C, then $v_p = 0.000294$ m/s, and $K_s = 3400$, thus:

$$A_s = Q/0.000294 = 3400(Q) = K_s (Q) \quad (\text{B33})$$

where: A_s = surface area of sediment basin at the base of the settling zone

Q = design storm peak flow rate; typically $Q = 0.5 Q_1$

Q_1 = peak discharge from the 1 in 1 year ARI design storm

If near-uniform flow conditions do not occur throughout the basin, then the required surface area (A_s) is determined from the following equation:

$$\text{General equation:} \quad A_s = K_s . H_e . Q \quad (\text{B34})$$

Table B25 – Typical Type C & D settling zone and sediment storage depths

Type C & Type D basin geometry:						
Sediment storage = 50% (V_s)	All bank slopes, 1 in 2			Total depth, $D_T = 1.5$ m		
Typical basin dimensions based on a length:width ratio of 3:1 at mid-elevation of settling zone:						
Settling zone surface area [m^2]	80	100	200	400	800	1600
Settling zone volume, V_s [m^3]	48	65	158	346	730	1507
Total basin volume, V_T [m^3]	72	97	235	516	1090	2250
Settling zone depth (D_s) [m]	0.60	0.65	0.78	0.86	0.91	0.94
Ratio D_s/D_T as a percentage	39%	43%	52%	58%	61%	63%
Sediment storage (D_{ss}) [m]	0.91	0.85	0.72	0.64	0.59	0.56
Ratio D_{ss}/D_T as a percentage	61%	57%	48%	42%	39%	37%
Mid length of settling zone [m]	15.5	17.3	24.5	34.6	49.0	69.3
Mid width of settling zone [m]	5.2	5.8	8.2	11.5	16.3	23.1

* The settling zone surface area represents the 'average' surface area, $A_s = V_s/D_s$.

Table B26 – Typical Type C & D settling zone and sediment storage depths

Type C & Type D basin geometry:						
Sediment storage = 50% (V_s)	All bank slopes, 1 in 2			Total depth, $D_T = 2.0$ m		
Typical basin dimensions based on a length:width ratio of 3:1 at mid-elevation of settling zone:						
Settling zone surface area [m^2]	150	300	600	1200	2400	4800
Settling zone volume, V_s [m^3]	121	304	680	1444	2995	6128
Total basin volume, V_T [m^3]	181	454	1015	2155	4470	9146
Settling zone depth (D_s) [m]	0.81	1.01	1.13	1.20	1.25	1.28
Ratio D_s/D_T as a percentage	40%	51%	56%	60%	62%	64%
Sediment storage (D_{ss}) [m]	1.19	0.99	0.87	0.80	0.75	0.72
Ratio D_{ss}/D_T as a percentage	60%	49%	44%	40%	38%	36%
Mid length of settling zone [m]	21.2	30.0	42.4	60.0	84.9	120
Mid width of settling zone [m]	7.1	10.0	14.1	20.0	28.3	40.0

Table B27 – Typical Type C & D settling zone and sediment storage depths

Type C & Type D basin geometry:						
Sediment storage = 50% (V_s)	All bank slopes, 1 in 2			Total depth, $D_T = 3.0$ m		
Typical basin dimensions based on a length:width ratio of 3:1 at mid-elevation of settling zone:						
Settling zone surface area [m^2]	350	500	1000	1500	3000	6000
Settling zone volume, V_s [m^3]	433	706	1634	2577	5450	11276
Total basin volume, V_T [m^3]	646	1054	2438	3847	8135	16830
Settling zone depth (D_s) [m]	1.23	1.40	1.63	1.71	1.81	1.88
Ratio D_s/D_T as a percentage	41%	47%	54%	57%	60%	63%
Sediment storage (D_{ss}) [m]	1.77	1.60	1.37	1.29	1.19	1.12
Ratio D_{ss}/D_T as a percentage	59%	53%	46%	43%	40%	37%
Mid length of settling zone [m]	32.4	38.7	54.8	67.1	94.9	134.2
Mid width of settling zone [m]	10.8	12.9	18.3	22.4	31.6	44.7

Step 6d: Sizing Type D basins

The settling pond within a Type D sediment basin is divided horizontally into two zones: the upper *settling zone* and the lower *sediment storage zone* as shown in Figure B10.

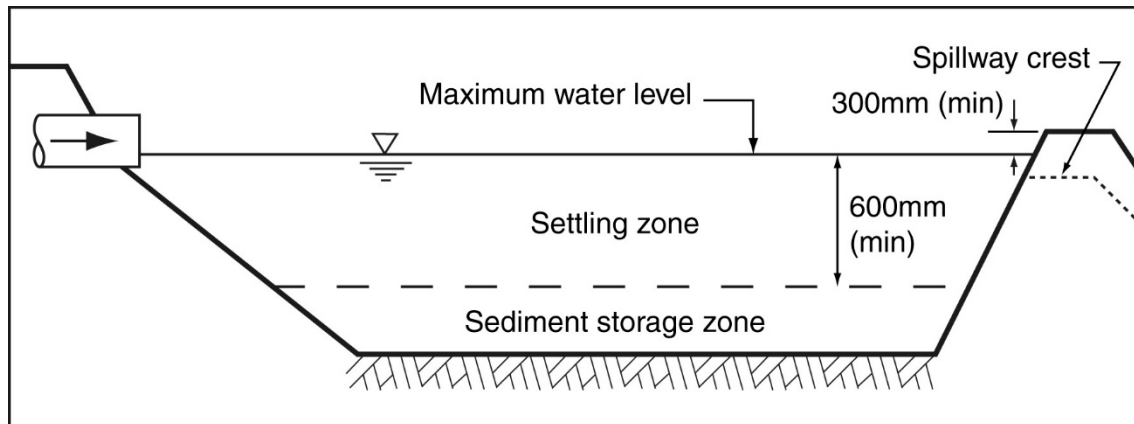

Figure B10 – Settling zone and sediment storage zone within a Type D basin

The minimum volume of the upper settling zone is defined by Equation B35.

$$V_S = 10 \cdot R_{(Y\%,5\text{-day})} \cdot C_v \cdot A \quad (\text{B35})$$

where: V_S = volume of the settling zone [m³]

$R_{(Y\%,5\text{-day})}$ = Y%, 5-day rainfall depth [mm]

C_v = volumetric runoff coefficient (refer to Table B31)

A = effective catchment surface area connected to the basin [ha]

The minimum recommended depth of the settling zone is 0.6 m, or L/200 for basins longer than 120 m (where L = effective basin length). Settling zone depths greater than 1 m should be avoided if particle settlement velocities are expected to be slow.

The desirable minimum length to width ratio of 3:1 is recommended for Type D basins. The length to width ratio is important for Type D basins because they operate as continuous-flow settling ponds (as per Type C basins) once flow begins to discharge over the emergency spillway. Step 8 provides guidelines on the use of internal baffles.

Equation B36 and tables B29 and B30 provide preliminary $R_{(Y\%,5\text{-day})}$ values for various locations. Both Equation B36 and tables B28 to B30 have been determined by developing a simple correlation between $R_{(Y\%,5\text{-day})}$ and the average 1 in 1 year, 120 hour (5-day) rainfall intensity based on the data obtained from Landcom (2004). It is highly recommended that actual $R_{(Y\%,5\text{-day})}$ values be determined for each region based on analysis of local rainfall records wherever practicable.

$$R_{(Y\%,5\text{-day})} = K_1 \cdot I_{(1\text{yr}, 120\text{hr})} + K_2 \quad (\text{B36})$$

where: K_1 = Constant (Table B28)

K_2 = Constant (Table B28)

$I_{(1\text{yr}, 120\text{hr})}$ = Average rainfall intensity for a 1 in 1 year ARI, 120 hr storm [mm/hr]

Recommendations on the choice of Y% and the respective K_1 and K_2 constants are provided in Table B28.

Table B28 – Recommended equation constants

Recommended application	Y%	K ₁	K ₂
Basins with design life less than 6 months	75%	12.9	9.9
Basins with a design life greater than 6 months	80%	17.0	11.2
Basins discharging to sensitive receiving waters.	85%	23.2	12.6
At the discretion of the regulatory authority	90%	33.5	14.2
At the discretion of the regulatory authority	95%	56.7	14.6

Where available space does not permit construction of the ideal sediment basin, then a smaller basin may be used; however, erosion control and site rehabilitation standards must be appropriately increased to a higher standard to compensate.

A Type D basin that is less than the ideal size must be considered either a Type 2 or Type 3 sediment trap based on the effective sediment trapping capabilities.

Type D basins are typically designed for a maximum 5-day cycle—that being the filling, treatment and discharge of the basin within a maximum 5-day period. In some tropical regions this may not be practical, and either a shorter or longer time frame may be required. The use of a shorter time period usually requires application of fast acting flocculants that may require a much higher degree of environmental management compared to gypsum. The use of a longer time period will require the construction of a significantly larger basin.

Unlike permanent stormwater treatment ponds and wetlands, Type D basins are not designed to allow high flows to bypass the basin. Even when the basin is full, sediment-laden stormwater runoff continues to be directed through the basin. This allows the continued settlement of coarse-grained particles contained in the flow. Such basin management practices may allow some re-suspension and discharge of previously settled fine sediments during heavy storms, but the task of trapping the anticipated large volume of sand and coarse silts washed from a construction site is considered more important.

In effect, Type D basins are designed to produce high quality outflows during the more frequent light storms (i.e. storms less than the 1 in 1 year ARI storm), but to also allow the continued trapping of coarse sediment during the less frequent heavy storms (i.e. storms equal to, or greater than, the 1 in 1 year ARI storm).

The volumetric runoff coefficient (C_v) is **not** the same as the discharge runoff coefficient (C) used in the Rational Method to calculate peak runoff discharges. Refer to Appendix A for further discussion on construction site hydrology.

Typical values of the volumetric runoff coefficient are presented in Table B31. These values are based on the soil groups presented in Section A3.1, Appendix A – *Construction site hydrology and hydraulics*. For impervious surfaces a volumetric runoff coefficient of 1.0 is adopted.

Table B29 – Queensland 1 year, 5-day rainfall intensity, and default values for 75%, 80%, 85% & 90% 5-day rainfall depth

Location (North to South)	South	East	Intensity (mm/hr) (1yr, 120hr)	Default 5-Day Rainfall depth "R" (mm)			
				75th%	80th%	85th%	90th%
Weipa	12.657	141.909	1.45	28.7	35.8	46.2	62.7
Cairns	16.917	145.767	2.65	44.2	56.2	74.1	103
Mareeba	17.000	145.433	1.34	27.2	33.9	43.7	59.0
Innisfail	17.533	146.017	3.50	55.2	70.6	93.8	131
Blunder Creek	17.733	145.433	1.39	27.9	34.8	44.8	60.7
Nitchaga Creek	17.733	145.617	2.72	45.1	57.4	75.7	105
Ingham	18.650	146.167	2.74	45.4	57.7	76.1	106
Blueswater Creek	19.167	146.533	2.08	36.8	46.5	60.8	83.8
Townsville	19.267	146.817	1.92	34.7	43.8	57.1	78.4
Ayr	19.567	147.400	1.63	31.0	38.9	50.4	68.7
Bowen	20.017	148.250	1.73	32.3	40.6	52.7	72.1
Charters Towers	20.083	146.267	0.85	20.9	25.6	32.3	42.6
Mt Isa	20.733	139.483	0.74	19.5	23.8	29.8	39.0
Mary Kathleen	20.783	139.983	0.77	19.9	24.3	30.5	40.0
Mackay	21.150	149.183	1.92	34.7	43.8	57.1	78.4
Winton	22.383	143.033	0.68	18.7	22.7	28.4	36.9
Yeppoon	23.133	150.733	1.64	31.1	39.0	50.6	69.1
Rockhampton	23.367	150.533	1.24	25.9	32.2	41.4	55.7
Longreach	23.450	144.250	0.70	19.0	23.1	28.8	37.6
Emerald	23.517	148.167	0.86	21.0	25.8	32.5	43.0
Blackwater	23.583	148.883	0.83	20.6	25.3	31.8	42.0
Gladstone	23.85	151.267	1.27	26.3	32.8	42.1	56.7
Biloela	24.400	150.517	0.82	20.5	25.1	31.6	41.6
Moura	24.567	149.983	0.80	20.3	24.8	31.2	41.0
Bundaberg	24.867	152.350	1.18	25.2	31.2	40.0	53.7
Maryborough	25.533	152.700	1.38	27.8	34.6	44.6	60.4
Gayndah	25.617	151.617	0.76	19.7	24.1	30.2	39.6
Gympie	26.183	152.667	1.38	27.8	34.6	44.6	60.4
Charleville	26.400	146.250	0.60	17.7	21.4	26.5	34.3
Kingaroy	26.533	151.833	0.73	19.3	23.6	29.5	38.6
Roma	26.583	148.783	0.62	17.9	21.7	27.0	34.9
Nambour	26.633	152.967	1.88	34.2	43.1	56.2	77.1
Maroochydore	26.650	153.100	1.79	33.1	41.6	54.1	74.1
Chinchilla	26.733	150.633	0.65	18.3	22.2	27.7	35.9
Mooloolah River	26.750	152.967	1.96	35.3	44.5	58.1	79.8
Caloundra	26.800	153.133	1.73	32.3	40.6	52.7	72.1
Caboolture	27.083	152.950	1.46	28.8	36.0	46.5	63.0
Dalby	27.183	151.250	0.59	17.5	21.2	26.3	33.9
South Pine River	27.333	152.917	1.45	28.7	35.8	46.2	62.7
Samford	27.367	152.883	1.41	28.1	35.1	45.3	61.4
Brisbane	27.467	153.017	1.34	27.2	33.9	43.7	59.0
Bulimba	27.533	153.133	1.54	29.8	37.3	48.3	65.7
Toowoomba	27.567	151.950	0.86	21.0	25.8	32.5	43.0
Ipswich	27.617	152.783	0.94	22.1	27.2	34.4	45.6
Beenleigh	27.717	153.200	1.56	30.1	37.7	48.8	66.4
Southport	27.967	153.417	1.68	31.6	39.7	51.6	70.4
Beaudesert	27.983	153.000	0.96	22.3	27.5	34.9	46.3
Canungra	27.983	153.150	1.68	31.6	39.7	51.6	70.4
Boonah	28.000	152.683	0.87	21.2	26.0	32.8	43.3
Nerang River	28.000	153.300	1.70	31.9	40.0	52.0	71.1
St George	28.050	148.583	0.61	17.8	21.6	26.7	34.6
Back Creek	28.117	153.183	1.84	33.7	42.4	55.3	75.7
Warwick	28.217	152.033	0.69	18.8	22.9	28.6	37.3
Inglewood	28.417	151.083	0.67	18.6	22.6	28.1	36.6
Goondiwindi	28.550	150.300	0.64	18.2	22.1	27.4	35.6
Stanthorpe	28.667	151.933	0.75	19.6	23.9	30.0	39.3

Table B30 – 1 year, 5-day rainfall intensity, and default values for 75%, 80%, 85% & 90% 5-day rainfall depth

Location	I _(1yr, 120hr)	R(75%)	R(80%)	R(85%)	R(90%)
New South Wales/ACT:					
Lismore *	1.56	28.6	35.3	45.2	60.2
Taree *	1.37	25.0	31.7	41.2	55.9
Newcastle *	1.21	24.4	30.5	38.9	51.8
Bathurst *	0.56	16.8	20.6	24.9	31.4
Sydney *	1.30	23.3	29.7	38.8	55.2
Bega *	–	19.5	24.6	32.5	46.2
Albury *	0.58	20.0	23.7	28.4	35.2
Canberra	0.54	16.9	20.4	25.1	32.3
Victoria:					
Mildura	0.32	14.0	16.6	20.0	24.9
Bendigo	0.41	15.2	18.2	22.1	27.9
Sale	0.46	15.8	19.0	23.3	29.6
Melbourne	0.55	17.0	20.6	25.4	32.6
Warrnambool	0.42	15.3	18.3	22.3	28.3
Ballarat	0.45	15.7	18.9	23.0	29.3
Tasmania:					
Launceston	0.48	16.1	19.4	23.7	30.3
Hobart	0.51	16.5	19.9	24.4	31.3
South Australia:					
Port Augusta	0.28	13.5	16.0	19.1	23.6
Port Lincoln	0.32	14.0	16.6	20.0	24.9
Adelaide	0.39	14.9	17.8	21.6	27.3
Mt Gambier	0.44	15.6	18.7	22.8	28.9
Western Australia:					
Broome	0.71	19.1	23.3	29.1	38.0
Geraldton	0.46	15.8	19.0	23.3	29.6
Perth	0.60	17.6	21.4	26.5	34.3
Bunbury	0.67	18.5	22.6	28.1	36.6
Albany	0.44	15.6	18.7	22.8	28.9
Northern Territory:					
Darwin	1.45	28.6	35.9	46.2	62.8
Katherine	1.01	22.9	28.4	36.0	48.0

* Rainfall depth (R) values sourced from Landcom (2004).

Table B31 – Typical single storm event volumetric runoff coefficients^[1]

Rainfall (mm) ^[2]	Soil Hydrologic Group (refer to Section A3.1, Appendix A)			
	Group A Sand	Group B Sandy loam	Group C Loamy clay	Group D Clay
10	0.02	0.10	0.09	0.20
20	0.02	0.14	0.27	0.43
30	0.08	0.24	0.42	0.56
40	0.16	0.34	0.52	0.63
50	0.22	0.42	0.58	0.69
60	0.28	0.48	0.63	0.74
70	0.33	0.53	0.67	0.77
80	0.36	0.57	0.70	0.79
90	0.41	0.60	0.73	0.81
100	0.45	0.63	0.75	0.83

Notes: [1] Sourced from Fifield (2001) and Landcom (2004).

[2] Rainfall depth based on the nominated 5-day rainfall depth, $R_{(Y\%,5\text{-day})}$.

The coefficients presented in Table B31 apply **only** to the pervious surfaces with a low to medium gradient (i.e. < 10% slope). Light to heavy clays compacted by construction equipment should attract a volumetric runoff coefficient of 1.0. For loamy soils compacted by construction traffic, adopt a coefficient no less than those values presented for Group D soils.

For catchments with mixed surface areas, such as a sealed road surrounded by soils of varying infiltration capacity, a composite coefficient must be determined using Equation B37.

$$C_{V(\text{comp.})} = \frac{\sum(C_{V,i} \cdot A_i)}{\sum(A_i)} \quad (\text{B37})$$

where:

$C_{V(\text{comp.})}$ = Composite volumetric runoff coefficient

$C_{V,i}$ = Volumetric runoff coefficient for surface area (i)

A_i = Area of surface area (i)

The volumetric runoff coefficient for impervious surfaces directly connected to the drainage system (e.g. sealed roads discharging concentrated flow to a pervious or impervious drainage system) should be adopted as 1.0.

The volumetric runoff coefficient for impervious surfaces **not** directly connected to the drainage system (e.g. a footpath or sealed road discharging sheet flow to an adjacent pervious surface) should be adopted as the average of the runoff coefficients for the adjacent pervious surface and the impervious surface (assumed to be 1.0).

If the coefficient is being determined for the design of a sediment basin established within a loamy or clayey soil catchment, then a volumetric runoff coefficient of 1.0 is recommended for all compacted soils and any areas exposed to heavy construction traffic.

Step 7: Determine the sediment storage volume

The sediment storage zone lies below the settling zone as defined in Figure B11. In the case of a Type A basin, the sediment storage zone also lies beneath the *free water zone*, which exists to separate the low-flow decant arms from the settled sediment.

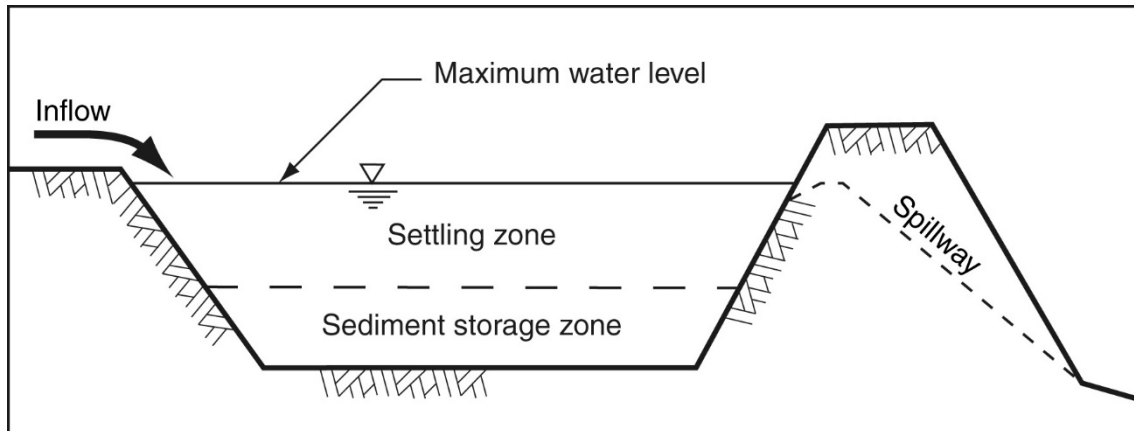

Figure B11 – Settling zone and sediment storage zone

The sediment storage zone is used to collect and hold settled sediment between periods of basin maintenance (de-silting). The minimum recommended volume of the sediment storage zone is defined below in Table B32. If less sediment storage volume is provided, then the basin will need to be de-silted more frequently. If a greater sediment storage volume is provided, then the frequency of basin maintenance will be reduced.

Table B32 – Sediment storage volume

Basin type	Minimum sediment storage volume
Type A and Type B	30% of settling volume (V_s)
Type C	50% of settling volume
Type D	50% of settling volume

Alternatively: the volume of the sediment storage zone may be determined by estimating the expected sediment runoff volume over the desired maintenance period, typically not less than 2 months.

Appendix E – *Soil loss estimation* provides guidance on the estimation of sediment runoff volumes. The analysis should be based on the rainfall erosivity for the most erosive month during the period in which construction is likely to occur.

Step 8: Design of flow control baffles

Baffles may be used for a variety of purposes including:

- energy dissipation (e.g. inlet chambers, refer to design Step 9)
- the control of short-circuiting (e.g. internal baffles)
- minimising sediment blockage of the low-flow outlet structure (outlet chambers).

For Type C & D basins, the need for flow control baffles should have been established in Step 6 based on the basin's length to width ratio. Both inlet baffles (inlet chambers) and internal baffles can be used to improve the hydraulic efficiency of Type C basins, thus reducing the size of the settling pond through modifications to the hydraulic efficiency correction factor.

Outlet chambers are technically not 'flow control baffles', but are instead used to prevent sediment settling around, and causing blockage to, certain types of decant structures. When placed around *riser pipe outlet systems* (Type C basins), these chambers can reduce the maintenance needs of the riser pipe. When placed around low-set, floating skimmer pipes, these chambers can prevent settled sediment stopping the free movement of these decant pipes. Outlet chambers are not required on Type A basins because the floating decant system sits above the maximum allowable elevation of the settled sediment.

(i) Internal baffles – flow redirection

Internal baffles are used to increase the effective length-to-width ratio of the basin. Figure B12 demonstrates the arrangement of internal flow control baffles for various settling pond layouts.

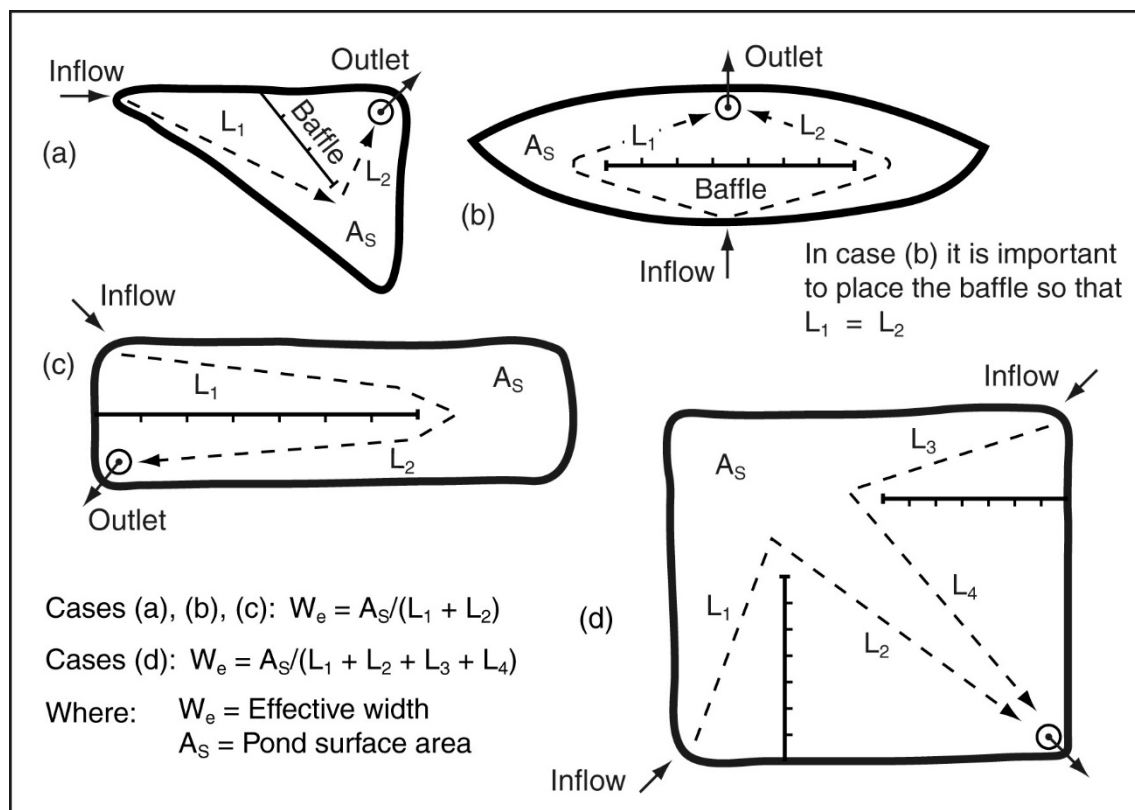

Figure B12 – Typical arrangement of internal flow control baffles (USDA, 1975)

If internal baffles are used, then the flow velocity within the settling pond must not exceed the sediment scour velocity as defined in Table B33.

Table B33 – Sediment scour velocities

Critical particle diameter (mm)	Scour velocity (m/s)
0.10	0.16
0.05	0.11
0.02	0.07

The crest of these baffles should be set level with, or just below, the crest of the emergency spillway. This is to prevent the re-suspension of settled sediment during severe storms (i.e. flows in excess of the basin's design storm should be allowed to overtop these baffles).

(ii) Internal baffles – in-line permeable

Internal baffles can also be used to ensure uniform flow through a basin. These permeable internal baffles can assist performance of all basin types even in standard basin shapes (Figure B13). The use of permeable internal baffles is especially recommended for Type A and Type B basins as they assist in limiting any short circuiting and can also assist in settling of flocs through against the mesh.

Permeable in-line baffles can typically be constructed using a fixed or floating system. Fixed systems will typically incorporate posts mounted in the floor and wall of the basins with a mesh attached to the posts. The height of the posts and mesh should be at approximately the same height as the emergency spillway to avoid a concentrated flow on the upper layer of the water column above the baffle. An alternative option is to use a baffle incorporating floats to keep the mesh on the top of the water column and weighting to fix the baffle to the floor of the basin. This can be generally be achieved by utilising proprietary silt curtains.

A critical component of in-line permeable baffles is the open area of the product. Too tight a weave and the baffles will actually hinder performance, with too open a weave providing little benefit. A 75% weave shade cloth or equivalent open area is recommended for in-line permeable baffles. Note this is significantly more open than typical silt curtains used on construction sites.

(iii) Outlet chambers

Outlet chambers (figures B14 and B15) are used to keep the bulk of the settled sediment away from certain low-flow outlet systems, particularly riser pipe outlets and flexible skimmer pipe outlets.

Maintenance of a sediment basin can be expensive if the basin's low-flow outlet system becomes blocked with sediment, or if the outlet is damaged during the de-silting operation. A sediment control barrier constructed around the outlet system limits the deposition of coarse sediment around the outlet structure, thus reducing maintenance costs and improving the long-term hydraulics of the basin.

The use of an outlet chamber is mandatory when a flexible skimmer pipe outlet system is employed.

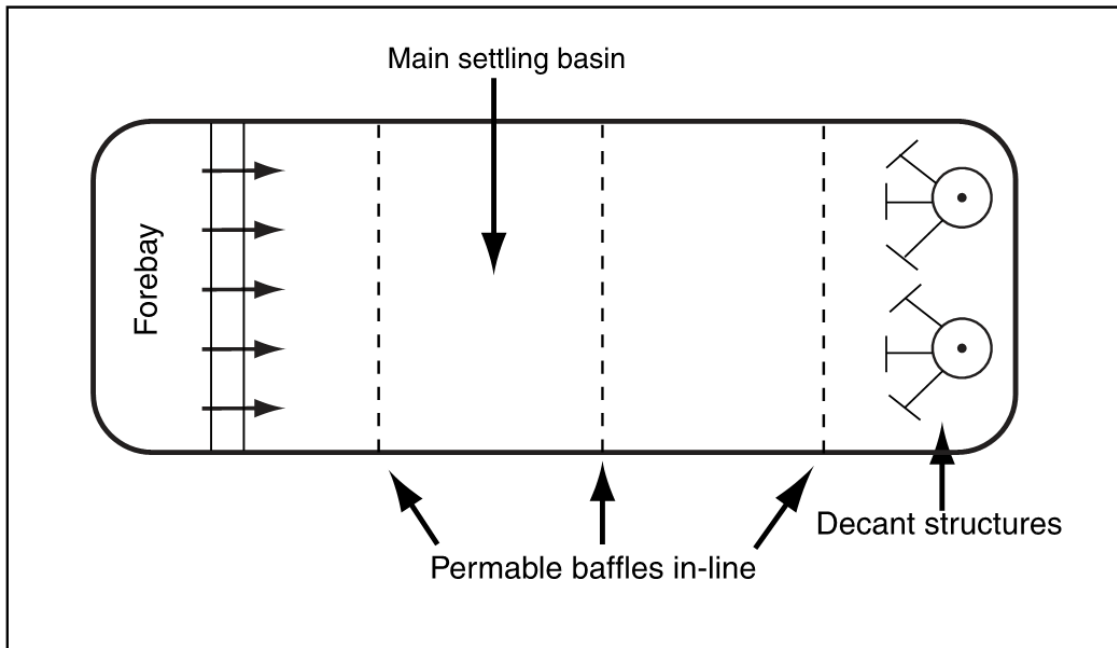

Figure B13 – Typical arrangement of in-line permeable baffles

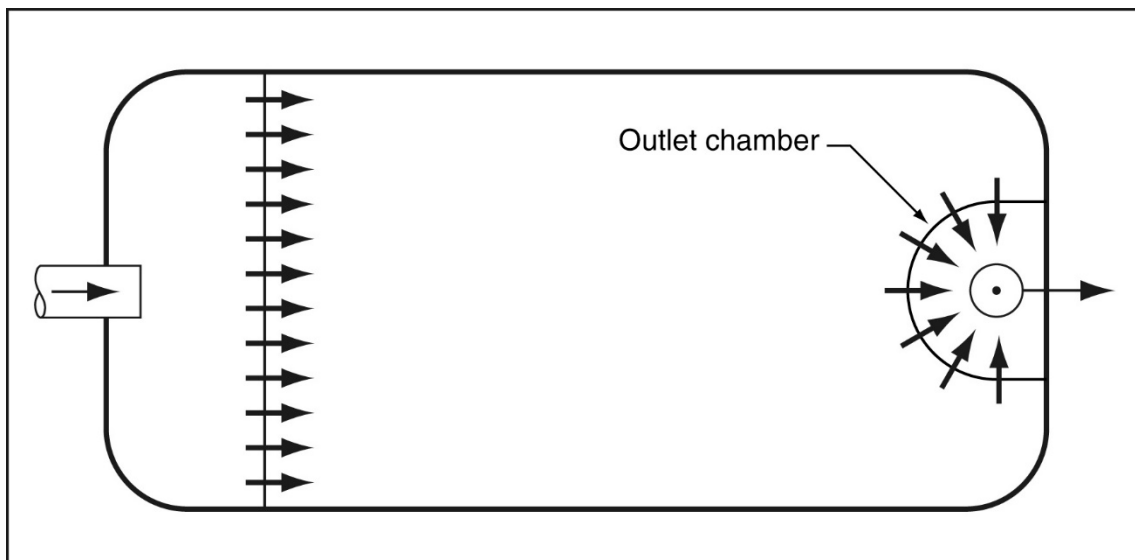

Figure B14 – Typical arrangement of an inlet and outlet chamber (plan view)

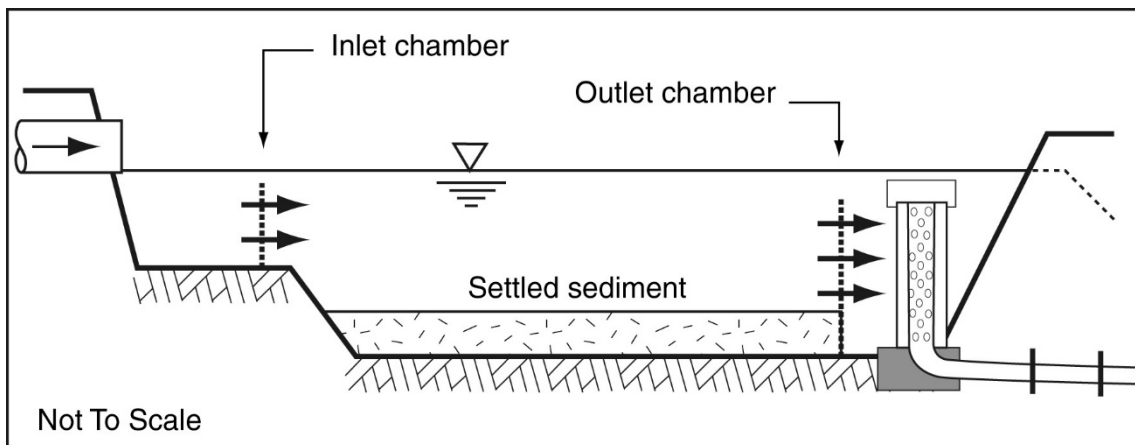

Figure B15 – Typical arrangement of an inlet and outlet chamber (long-section)

Step 9: Design the basin's inflow system

Surface flow entering the basin should not cause erosion down the banks of the basin. If concentrated surface flow enters the basin (e.g. via a *Catch Drain*), then an appropriately lined chute will need to be installed at each inflow point to control scour.

For Type A and B basins it is necessary to establish energy dissipation and an inlet chamber to promote mixing of the coagulant or flocculant and promote uniform flow into the main basin cell through the use of a level spreader.

If flow enters the basin through pipes, then wherever practicable, the pipe invert should be above the spillway crest elevation to reduce the risk of sedimentation within the pipe. Submerged inflow pipes must be inspected and de-silted (as required) after each inflow event.

Constructing an appropriately designed pre-treatment pond or inlet chamber can be used to both improve the hydraulic efficiency of the settling pond, and reduce the cost and frequency of de-silting the main settling pond.

Discussion:

Where space is available, the construction of an inlet (pre-treatment) pond or inlet chamber can significantly reduce the cost of regular de-silting activities for large and/or long-term basins. Figures B16–B21 and B24–B27 demonstrate typical arrangements. These ponds are designed to collect the bulk of the coarse sediment. Their size and location should allow de-silting by readily available on-site equipment such as a backhoe.

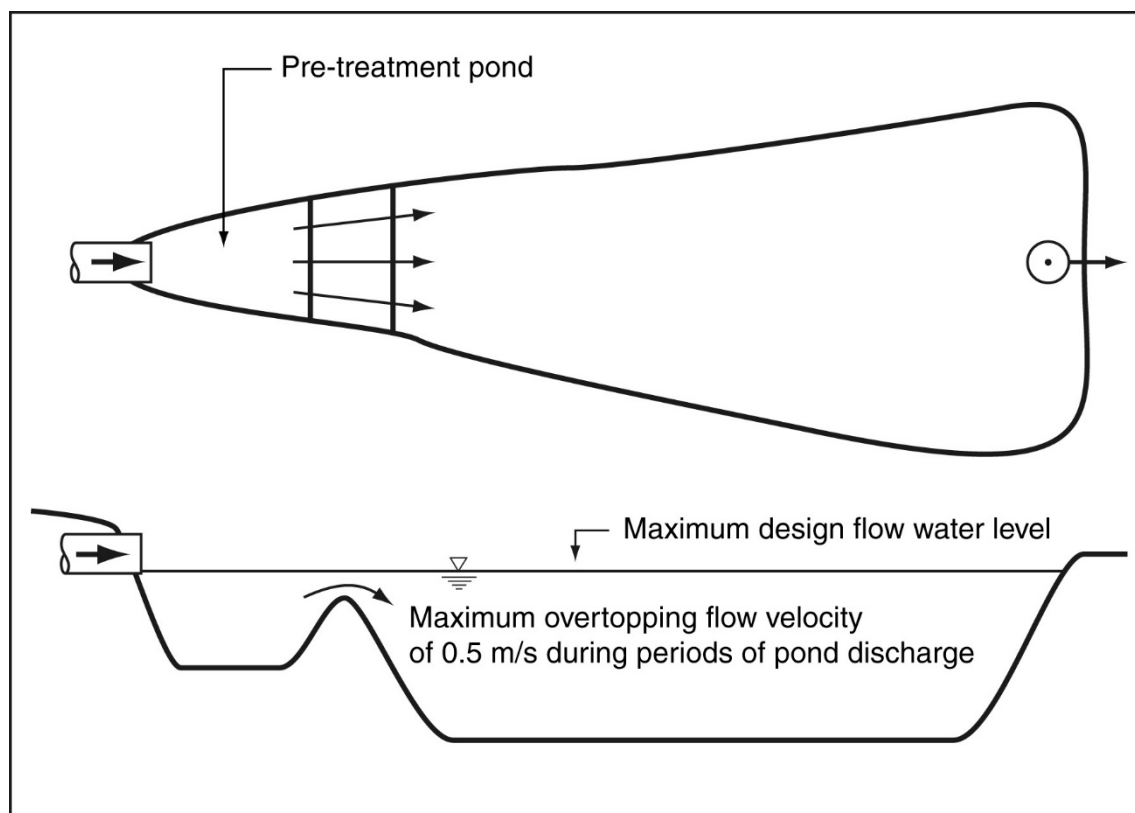

Figure B16 – Pre-treatment inlet pond

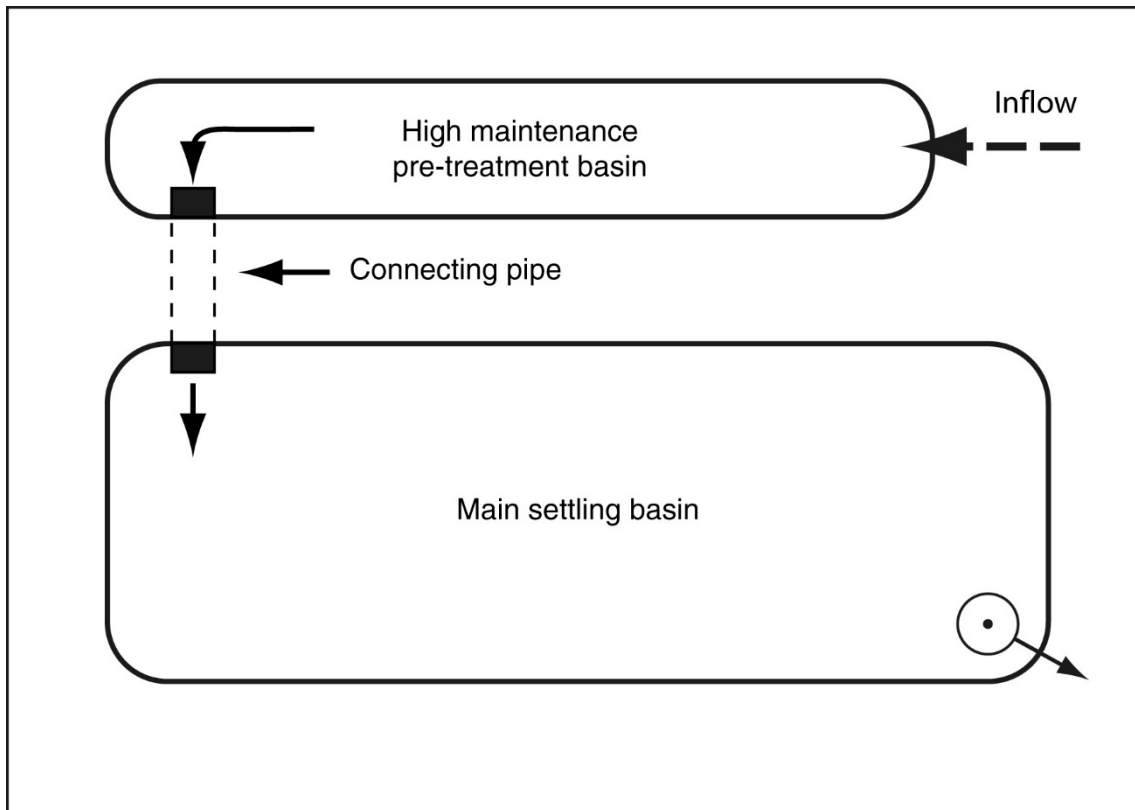

Figure B17 – Pre-treatment inlet pond

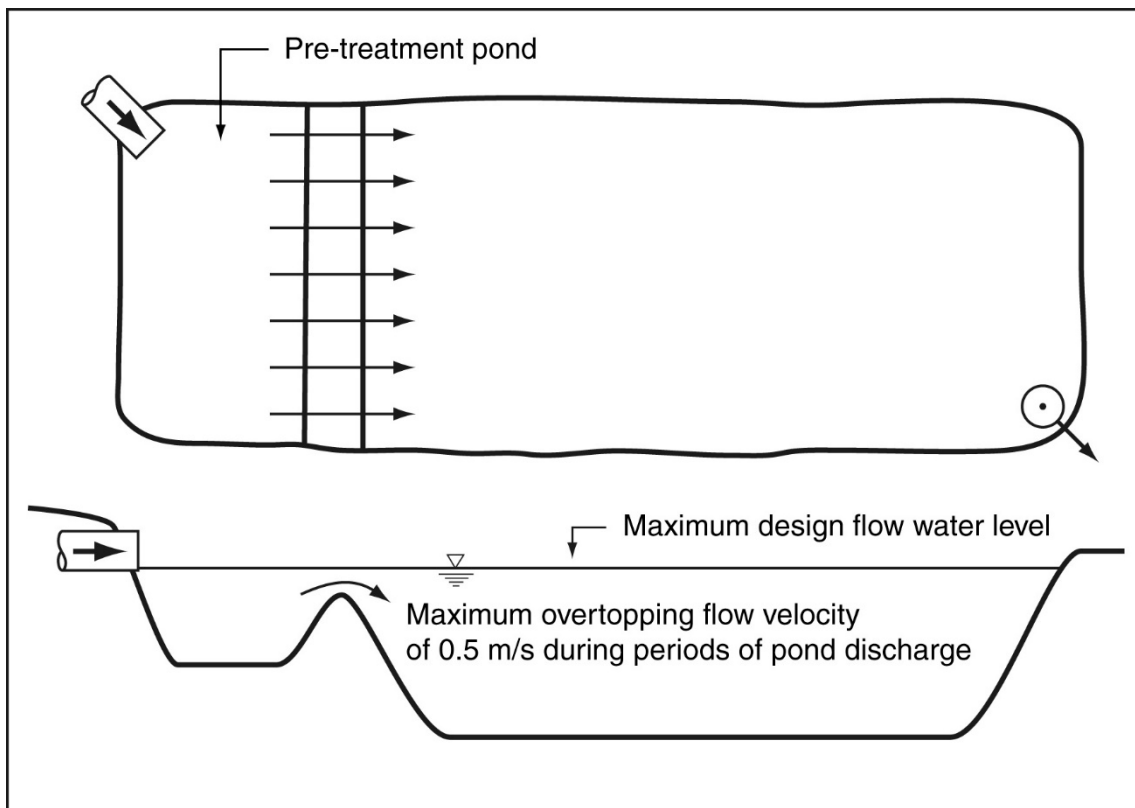

Figure B18 – Pre-treatment inlet pond

(i) Inlet chamber – Type A and B basins

For Type A and B basins it is necessary to establish an inlet chamber for energy dissipation, and to promote mixing of the coagulant or flocculant, and a level spreader to promote uniform flow into the main basin cell. It is critical that runoff enters the inlet chamber and not the main basin cell to ensure mixing of the coagulant and to avoid short-circuiting.

Topography and site constraints may dictate the location and number of inflow points. The optimum approach is to have a single inflow point as shown in Figure B19 to promote chemical mixing and flexibility in selection of the chemical dosing system.

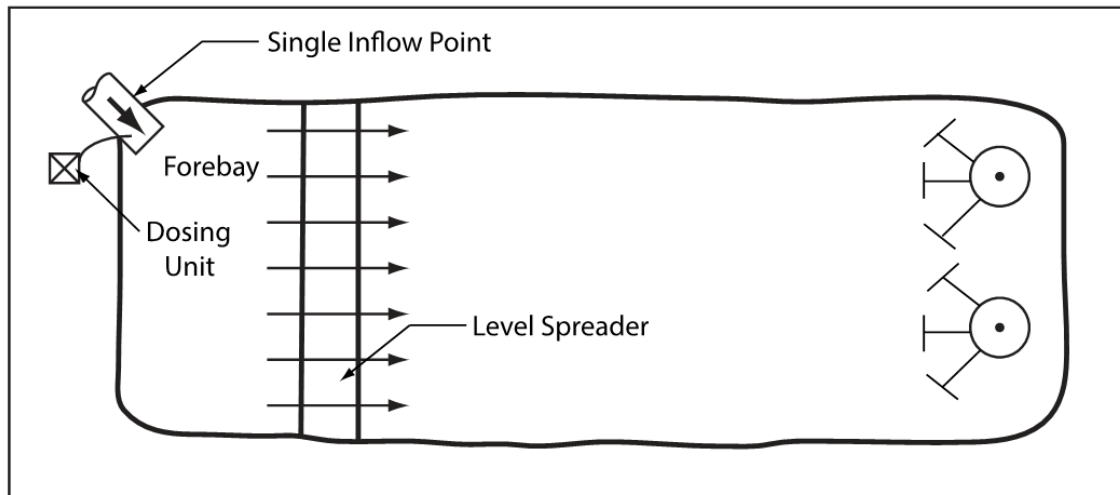

Figure B19 – Single inflow to Type A and B basin

Where constraints do not allow a single inflow point, runoff can be discharged into the forebay in multiple locations as shown in Figure B20. Multiple inlets may constrain the type, or govern the number of chemical dosing units required. In a multiple inlet location, the objective is for thorough mixing of the coagulant with all runoff. Consequently, where a single dosing system is adopted, inflow direction and location should be designed to optimise mixing of all runoff in the forebay.

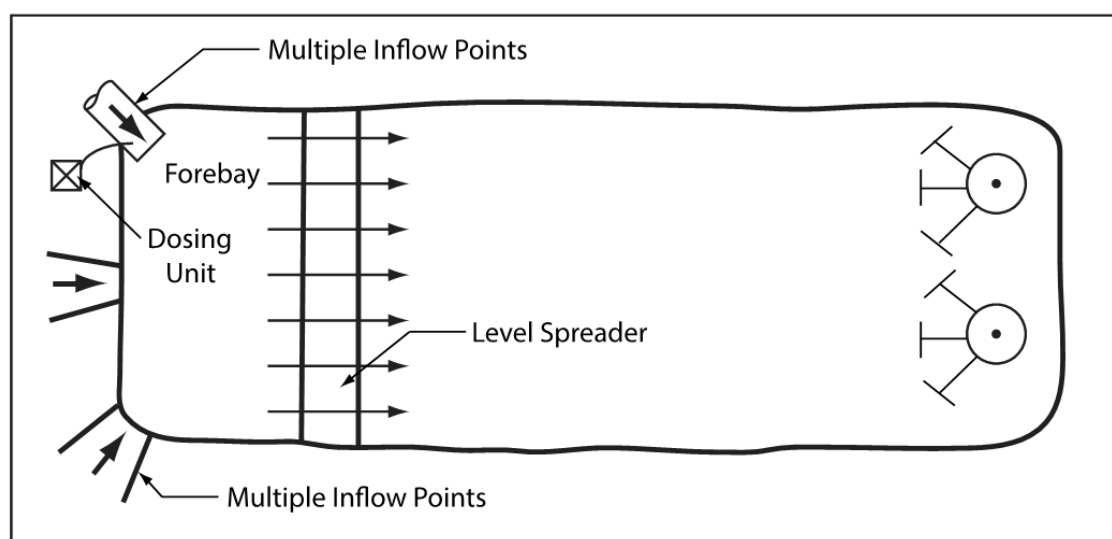

Figure B20 – Multiple inflows to a Type A or B basin

In some circumstances a catchment will be able to enter the main basin from the side. In these situations, a bund or drain should be placed along the length of the basin to direct runoff to the inflow point where feasible as shown in Figure B21. This situation is likely to frequently occur on linear infrastructure projects and can be managed through informative design and an understanding of progressive earthworks levels.

If all runoff cannot practicably be diverted back to the forebay, then a drain or bund should be constructed to divert the maximum catchment possible. The remaining catchment that cannot be diverted to the inflow point can then be managed through erosion control, or localised bunding to capture that runoff.

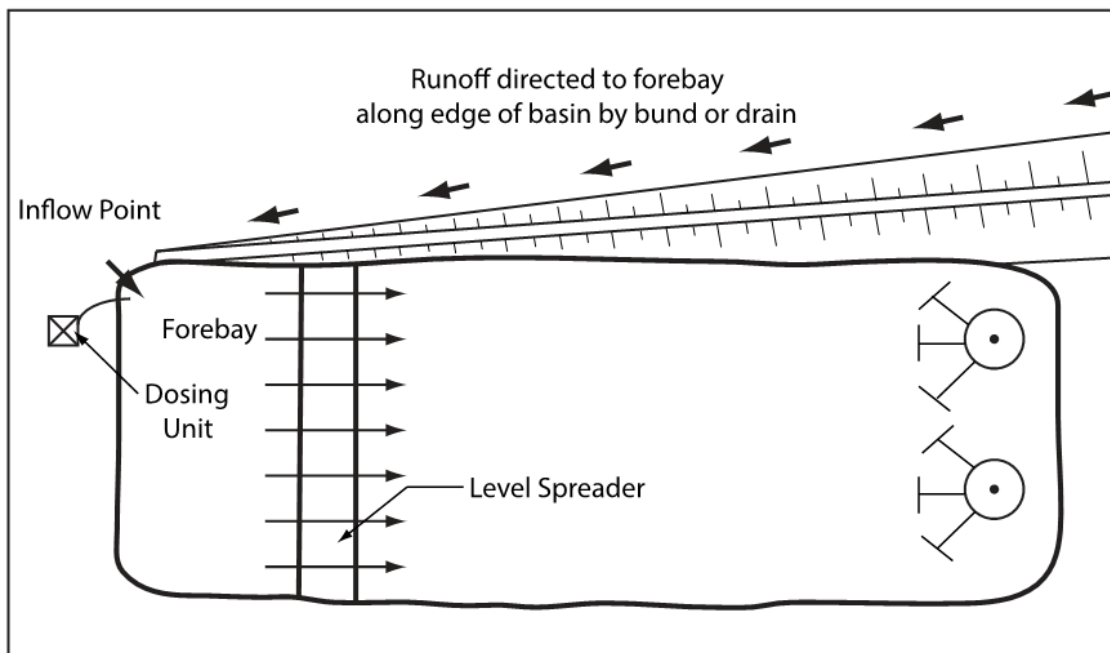

Figure B21 – Multiple inflows to a Type A or B basin

The inlet chamber (or forebay) should be sized at approximately 10% of the size of the main basin cell, and have a minimum length of 5 m unless site constraints preclude this size. To avoid re-suspension of floc particles a minimum depth of 1.0 m is recommended. Where site constraints do not allow the construction of a forebay to the recommended dimensions, monitoring of the performance of the forebay should be undertaken to determine the requirement for any modifications.

A critical component of the inlet chamber is to spread flow into the main basin cell to promote uniform flow to the outlet. To achieve uniform flow the construction of a level spreader is required. The level spreader can be constructed of a range of material including timber, concrete and aluminium. A typical detail of a level spreader is provided in Figure B22, however alternative approaches can be adopted as long as the design intent is achieved. Care is to be undertaken to minimise any potential for scour on the down-slope face of the level spreader. Protection of the soil surface will be required with concrete, geotextile, plastic or as dictated by the soil properties, slope of the batter face and flow velocity. The level spreader is to be constructed 100–200 mm above the emergency spillway level or as required to ensure the level spreader functions during high events and is not flooded due to water in the main basin cell.

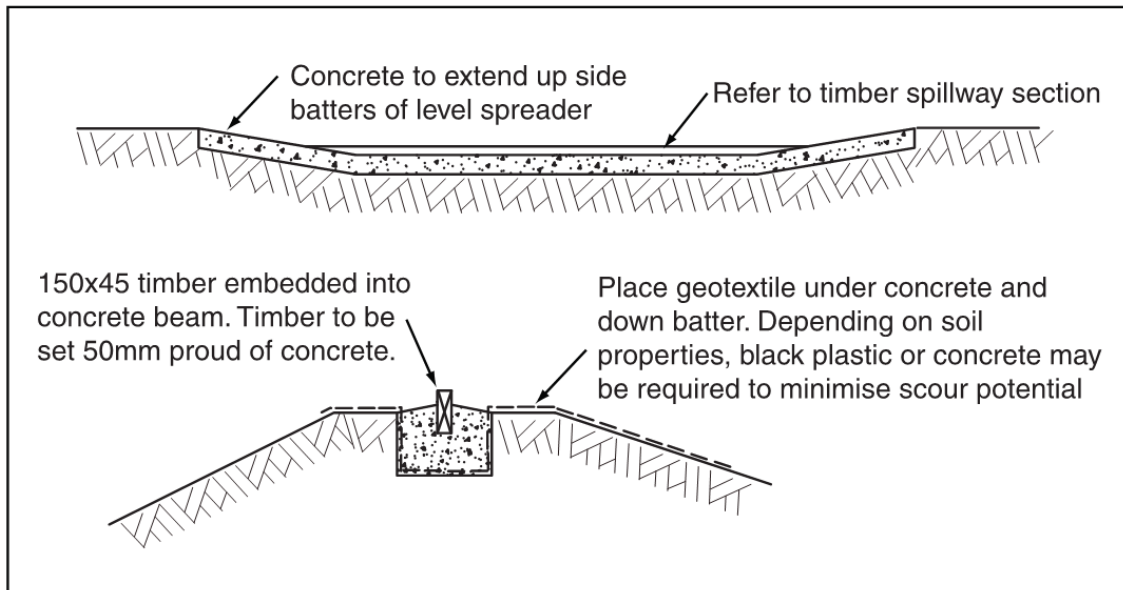

Figure B22 – Typical detail for a Type A and B basin level spreader

It is critical that the spreader is level because any minor inaccuracy in construction can direct flow to one side of the main basin cell resulting in short-circuiting and a significant reduction the performance of the basin. Where long spreaders are installed, the use of a multiple V-notch weir plate (Figure B23) is recommended to overcome difficulties with achieving the required construction tolerances. A multiple V-notch weir plate can be fixed to a piece of timber embedded in concrete.

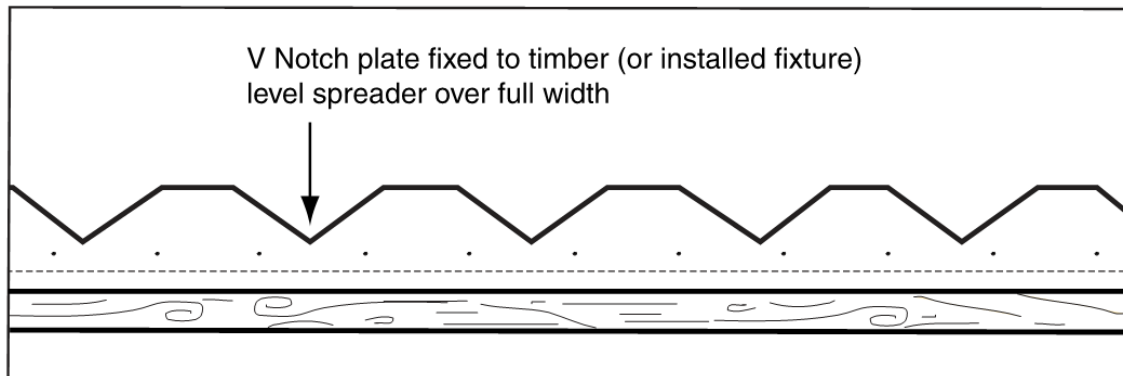

Figure B23 – Typical detail for multiple V-notch weir plate

(ii) Inlet chamber – Type C and D basins

Flow control baffles or similar devices may be placed at the inlet end of a *Sediment Basin* to form an inlet chamber in Type C and D basins (figures B24 to B27). These chambers are used to reduce the adverse effects of inlet jetting caused by concentrated, point source inflows. The objective of the inlet chamber is to produce near-uniform flow conditions across the width of the settling pond.

These types of inlet chambers are only applicable to Type C and D basins. For Type A and B basins it is necessary to establish energy dissipation and an inlet chamber. In Type C basins, inflow jetting can also promote the formation of dead water zones significantly reducing the hydraulic efficiency of the settling pond. As the length to width ratio decreases, the impact of these dead water zones increases.

Inflow jetting can also be a problem in Type D basins even though the sediment-laden water is normally retained for several days following the storm. During those storms when inflows exceed the storage volume of the basin, it is still important for the basin to be hydraulically efficient in order to maximise the settlement of the coarse sediment.

It is therefore always considered important to control the momentum of the inflow to:

- retain coarse sediments at the inlet end of the basin
- limit the re-suspension of the finer, settled sediments
- reduce short-circuiting within the basin
- reduce the frequency and cost of basin maintenance.

The main disadvantage of using an inlet chamber is that it can complicate the de-silting process, especially in small basins. Conversely, when used in large basins, an inlet chamber can reduce the long-term cost of de-silting operations by retaining the bulk of the coarse sediment within the inlet chamber where it can be readily removed by equipment such as a backhoe. In large basins, the inlet chamber effectively operates as a pre-treatment pond.

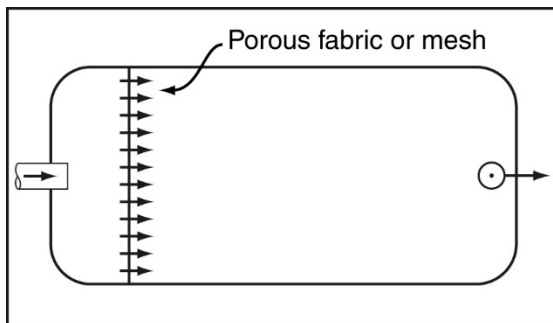

Figure B24(a) – Porous barrier inlet chamber

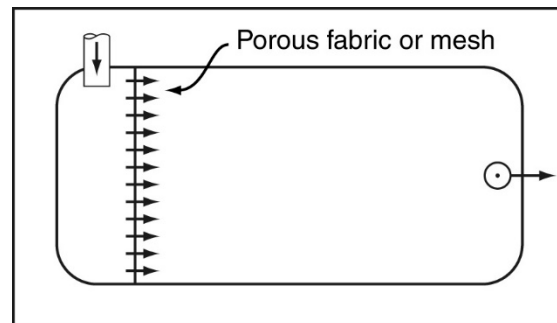

Figure B25(a) – Porous barrier with piped inflow entering from side of basin

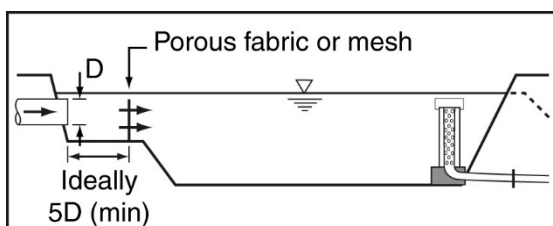

Figure B24(b) – Typical layout of inlet chamber with opposing inlet pipe (Type C basin)

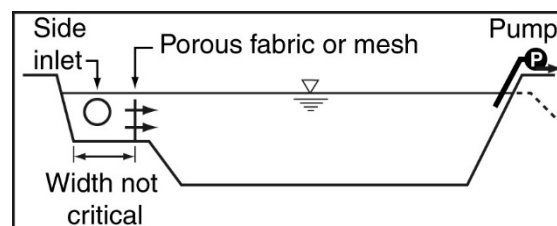

Figure B25(b) – Typical layout of inlet chamber with side inlet (Type D basin)

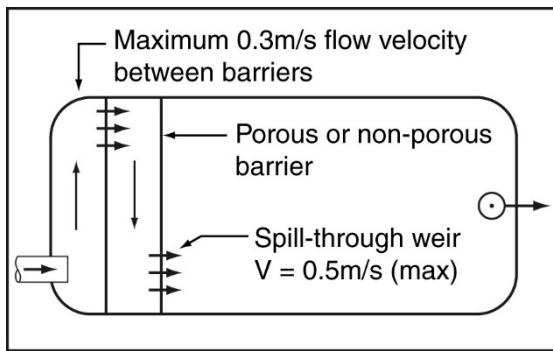

Figure B26(a) – Alternative inlet chamber design

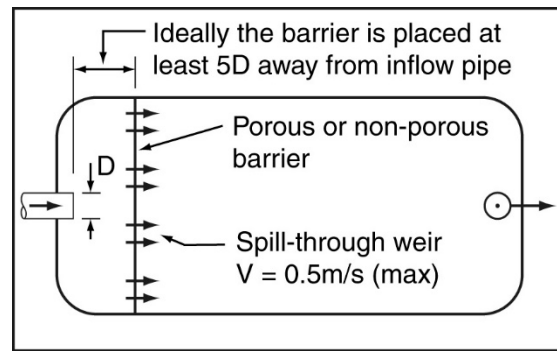

Figure B27(a) – Alternative inlet chamber design

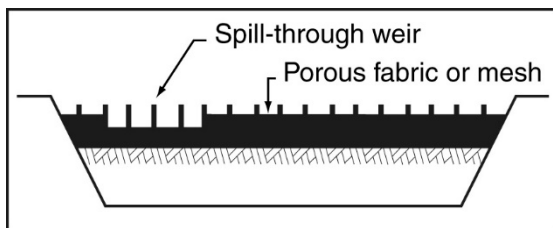

Figure B26(b) – Barrier with single spill-through weir per barrier

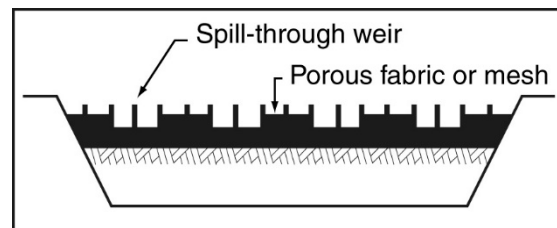

Figure B27(b) – Barrier with multiple spill-through weirs

The use of an inlet chamber is usually governed by the need to adopt a low hydraulic efficiency correction factor (H_e) in Step 6. The incorporation of inlet baffles should be given serious consideration within Type C basins if the expected velocity of any concentrated inflows exceeds 1 m/s.

Table B34 summarises the design of various inlet chambers.

Table B34 – Design of various inlet chambers

Baffle type	Description
Shade cloth	An inlet chamber formed by staking coarse shade cloth across the full width of the settling pond. Typical spacing between support posts is 0.5 to 1.0 m depending on the expected hydraulic force on the fence.
Perforated fabric	An inlet chamber formed from heavy-duty plastic sheeting or woven fabric. The sheeting/fabric is perforated with 50 to 100 mm diameter holes at approximately 300 mm centres across the full width and depth of the settling pond (Figure B28). Typical spacing between support posts is 0.5 to 1.0 m depending on the expected hydraulic force on the fence.
Solid porous or non-porous barrier, with or without spill-through weirs	A porous or non-porous barrier constructed across the full width of the settling pond. If the inlet pipe is directed towards the barrier, then the barrier should ideally be located at least 5 times the pipe diameter away from the inflow pipe. The barrier is designed to ensure that the inflow is distributed evenly across the width of the basin and that the velocity of flow passing over the barrier does not exceed 0.5 m/s during the 1 in 1 year peak discharge.

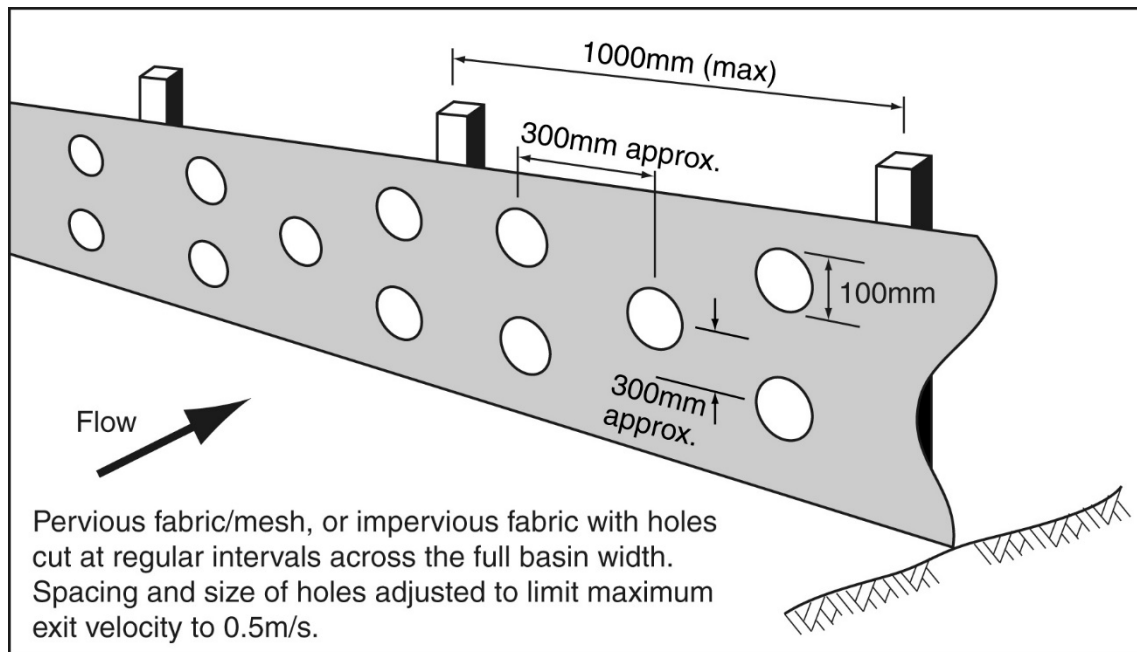

Figure B28 – Example arrangement of perforated fabric inlet baffle

The inlet chamber may have a pond depth less than the depth of the main settling pond (figures B24b & B25b) in order to allow for easy installation and maintenance of the barrier. An inlet chamber depth of around 0.9 m will allow the use of standard width *Sediment Fence* fabric as the baffle material.

The use of shade cloth (width of around 2.2 m) will allow the formation of a deeper inlet chamber, thus potentially reducing the frequency of de-silting operations.

Inflow pipes should ideally have an invert well above the floor of the inlet chamber to avoid sedimentation within the pipe.

Step 10: Design the primary outlet system

Historically, sediment basins were described as either 'dry' or 'wet' basins. This classification system can be seen as confusing because it refers only to the existence of an automatic draining system, and not to the option to retain water within the basin after storms so that the water can be used for on-site purposes. The traditional definition of wet and dry basins is provided below.

- Dry basins are free draining basins that fully de-water the settling zone after each storm. These usually include Type A and C basins.
- Wet basins are not free draining, but are designed to retain the stormwater runoff for extended periods in order to provide the basin with sufficient time for the gravitational settlement of fine sediment particles. These basins can include Type A, Type B, and Type D basins. Type A basins are included because the automatic decant system can be shut down if the basin's discharge fails to meet the pre-determined water quality objectives.

Type A basins require a floating low-flow decant system as described below.

Type B basins may not require a formal decant system, other than that required to de-water the basin prior to the next storm, or to extract the water for usage on the site.

Type C basins require a free-draining outlet system in the form of either a riser pipe outlet, or floating decant system. Gabion wall, *Rock Filter Dam*, and *Sediment Weir* outlet systems are not recommended unless a Type 2 sediment retention system has been specified.

The hydraulics of a Type C basin's primary outlet system must ensure that the peak water level is at least 300 mm below the crest of the emergency spillway during the basin's nominated design storm (i.e. $Q = 0.5 Q_1$).

Type D basins usually require a pumped discharge system similar to Type B basins. If a piped outlet exists, then a flow control valve must be fitted to the outlet pipe to allow full control of the basin discharge.

(i) Floating decant system for Type A basins:

Floating siphon outlet systems are designed to self-prime when the basin's water exceeds a predetermined elevation. These systems decant the basin by siphoning water from the top of the pond, thus always extracting the cleanest water. This also extends the settlement period by commencing decant procedures only when the pond level reaches the predetermined elevation.

Self-priming skimmer pipes are difficult to design and optimise. The Auckland-type, floating decant systems is depicted in Figure B29. This outlet system achieve 4.5 L/s per decant arm. Each decant arm has six rows of 10 mm diameter holes drilled at 60 mm spacings (totalling 200 holes) along the 2 m width of the decant arm.

If larger flow rates are required, multiple decants structures are to be installed. Flow rates can be controlled through the sizing and number of holes in the decant, or by using an orifice plate based on appropriate hydraulic calculations.

For small catchments, a single decant may be sufficient to achieve the required outflow rate. A single decant arm can connect directly into a pipe through the sediment basin wall negating the need for a manhole. Proprietary skimming systems are available and

can be used as long as they adhere to the design intent, and will not draw up floc particles due to concentrated flow.

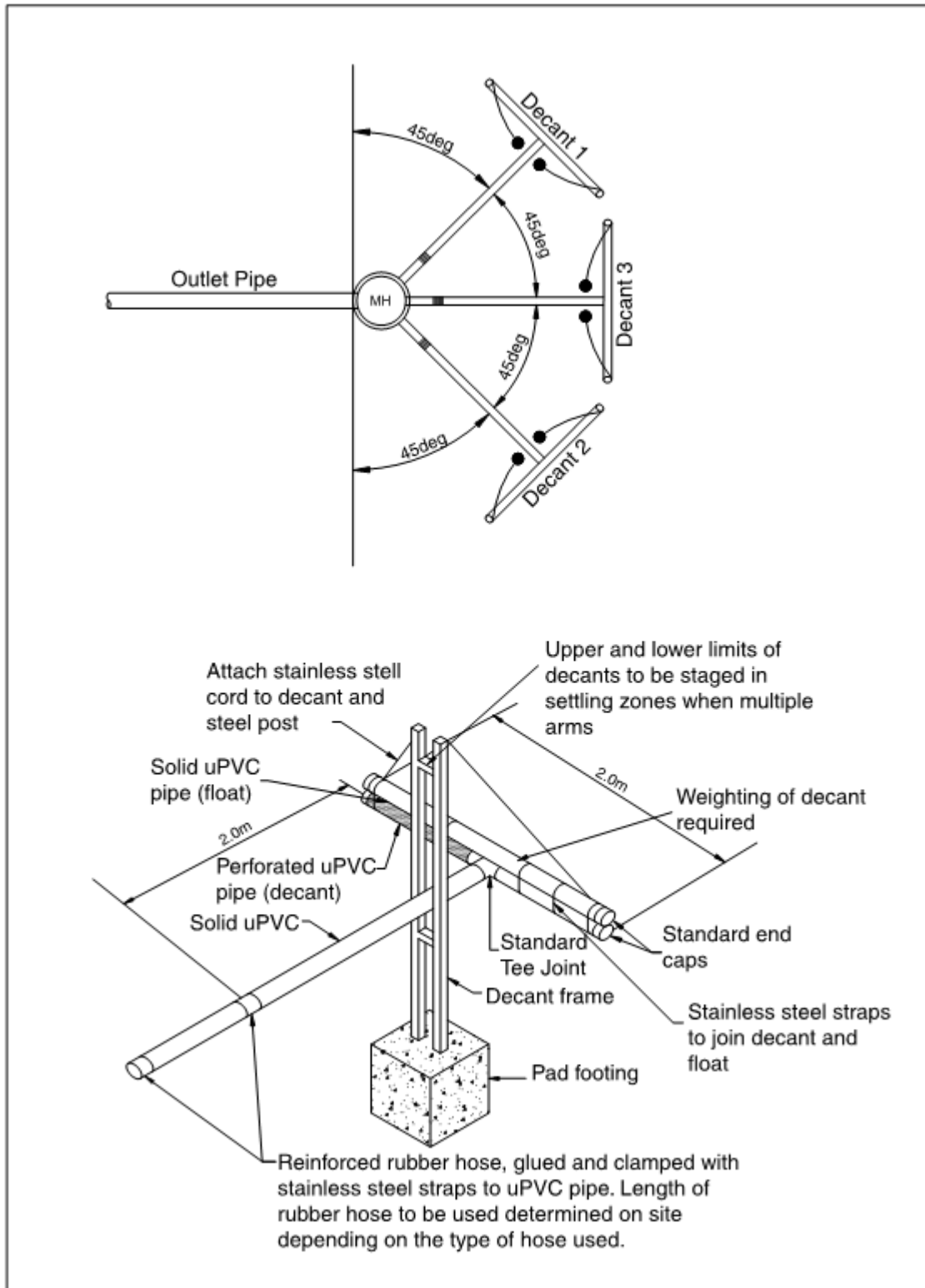

Figure B29 – Auckland-type floating decant system for Type A basins

(ii) Rock Filter Dam outlet systems (Type 2 system):

Rock Filter Dam outlet systems are only suitable for Type 2 sediment control devices. In this system a filter wall is constructed as the primary outlet system for the basin. The upstream face of the rock dam is either lined with aggregate, or a layer of non-woven filter cloth. Hydraulic design of the *Rock Filter Dam* should be in accordance with the relevant Fact Sheet presented in Book 4.

The use of an upstream aggregate filter has the advantage of generally being easy to replace with machinery such as a backhoe, but such filters are best used only in sandy soils.

Use of non-woven filter cloth as the primary filter medium has the advantage of being cheaper than aggregate; however, its replacement can be very messy and sediment leaks may occur if the replaced filter cloth is not installed properly. The filter cloth is usually placed over a layer of aggregate of uniform rock size, which is used to maintain the desired decant rate.

Due to the difficulties of replacing the filter cloth during maintenance operations, multiple layers of filter cloth can be installed, thus allowing the upper (sediment-laden) layer to be removed during maintenance. This procedure is not always successful because fine sediments can pass through several layers of filter cloth partially blocking each layer. Such sediment blockage, however, may indicate that multiple layers of filter cloth are actually required to achieve the desired water quality.

(iii) Gabion wall outlet systems (Type 2 system):

Gabion wall outlet systems are only suitable for Type 2 sediment control devices. The gabion walls should be lined on the inside with filter cloth, not aggregate or woven sediment fence fabric. The filter cloth should not be placed or anchored between the gabion baskets as this makes it very difficult to replace the filter cloth during maintenance.

Hydraulic design of gabion wall outlet systems should be in accordance with the relevant Fact Sheet presented for *Sediment Weirs* presented in Book 4.

(iv) Sediment weir outlet systems (Type 2 system):

Sediment Weir outlet systems are similar in structure and use to a gabion wall outlet system. They should only be used as an outlet system for Type 2 sediment control devices. Hydraulic design of the *Sediment Weir* should be in accordance with the relevant Fact Sheet presented in Book 4.

(v) Pumped outlet systems (Type B and D basins):

When de-watering any type of sediment basin it is extremely important for the process not to resuspend previously settled sediment. Thus, intake pipes must be housed in an appropriate flow control chamber to prevent settled sediment being removed from the basin. Intake pipes must **not** be allowed to rest on the bottom of the basin, or in any other location that will allow the entrainment of settled sediment.

An appropriate housing chamber for an intake pipe may be formed from a section of PVC drainage pipe, sealed at one end, and perforated along its length with intake holes.

As an alternative, the inflow pipe may be suspended from a floating raft that is designed to prevent the intake pipe from resting too close to the settled sediment. The intake pipe is normally placed inside a horizontal perforated PVC pipe attached to the underside of a floating raft. Perforations in the PVC pipe would only exist along the top of the pipe, thus minimising the risk of settled sediment being entrained into the outlet.

Pumped outlet systems should aim to discharge the basin's settling zone volume in **less** than 24 hours. The outflow must not cause erosion or adversely affect downstream environments, including occupied properties.

(vi) Perforated riser pipe outlets (Type C basins):

Key components of a perforated riser pipe outlet are listed below:

- Anti-flotation mass = 110% of the displaced water mass.
- Combined trash rack and anti-vortex screen placed on top of open riser pipe.
- Minimum outlet pipe size of 250 mm.
- Anti-seep collars (minimum of 1) placed on the buried outlet pipe.
- Designed to drain the basin's full settling zone volume in not less than 24 hours (to allow adequate settlement time).

(a) Pipe size: The minimum diameter of the outlet pipe should be 250 mm.

(b) Freeboard to spillway crest The top elevation of the riser pipe (or oil skimmer if used) should be a minimum 300 mm below the crest of the emergency spillway.

(c) Hydraulic capacity and freeboard: The primary outlet should be capable of discharging the peak flow from the relevant design storm when the pond water level is no less than 300 mm below the crest of the emergency spillway.

The screened open top of the riser pipe (Figure B30) can be used as a siphon spillway for storms in excess of the basin's design storm. Note; the basin's design storm is different from the design storm for the emergency spillway.

(d) Drainage holes: Minor perforation holes should exist throughout both the settling zone and the sediment storage zone. The primary (i.e. largest) drainage holes are located at the base of the settling zone. These holes are sized using the orifice discharge formula (Equation B38 – Goldman et al. 1986).

$$A_o = \frac{A_s \sqrt{2H}}{C_d T \sqrt{g}} \quad (\text{B38})$$

where:

A_o = surface area of primary drainage holes [m²]

A_s = average surface area of the settling zone = V_s/D_s [m²]

V_s = volume of settling zone [m³]

D_s = depth of settling zone [m]

H = head of water above orifice [m]

T = de-watering time [hours]

C_d = discharge coefficient (adopt $C_d = 0.60$)

g = gravitational constant (9.8 m/s²)

Equation B38 does **not** provide an appropriate analysis of basin drainage when multiple primary holes are used at various depths throughout the settling zone.

The de-watering holes must **not** be directly covered by filter cloth, instead spacers should be used to separate the filter from the surface of the riser pipe (Figure B33).

All de-watering holes must be covered with wire mesh if aggregate is used at the primary filter.

De-watering of the sediment storage zone can be achieved by locating additional minor drainage holes within the sediment storage zone.

(e) Primary filtration system:

An outlet riser pipe can be surrounded with a 'pyramid' of aggregate (Figure B30), or a vertical stand of rock-filled gabion baskets wrapped in heavy-duty filter cloth (Figure B32).

Alternatively, filter cloth can be used as the primary filter medium (figures B30 and B32). Outlet systems that incorporate the use of filter cloth must give appropriate consideration of ongoing maintenance issues, including regular replacement of the filter cloth. It should be noted that maintenance and sediment blockage of the filter cloth will be reduced as the total surface area of the filter cloth is increased.

The filter cloth must **not** be placed in direct contact with the riser pipe. An air gap is essential to ensure hydraulic efficiency of the filter cloth (Figure B33). Thus wire mesh should be wrapped around and secured to the perforated riser pipe before attaching the fabric.

To assist in separating the filter cloth from the riser pipe, vertical timber spacers (Figure B33) can be placed between the riser pipe and wire mesh.

(f) Oil skimmer:

An oil skimmer ring (figures B30 and B34) is normally placed around the top of the riser pipe to minimise the risk of floating debris and oil from entering the riser pipe.

(g) Debris screen:

A debris screen should be placed over the top of the riser pipe. Typically this screen is incorporated into the oil skimmer.

(h) Anti-vortex device:

An anti-vortex plate should be fitted to the top of the riser pipe as shown in Figure B34.

(i) Anti-flotation weight:

The design of any riser pipe system should include allowance for uplifting (buoyancy) forces on the structure in the form of a weighted concrete base. The weight of the anti-flotation mass (Figure B30) should be no less than 110% of the mass of water displaced by the riser pipe.

Gabion baskets must be securely fastened to the riser pipe if they are to act as the anti-flotation weight.

(j) Anti-seep collar:

At least 1 anti-seep collar must be placed on the riser pipe to prevent seepage along the outer surface of the pipe.

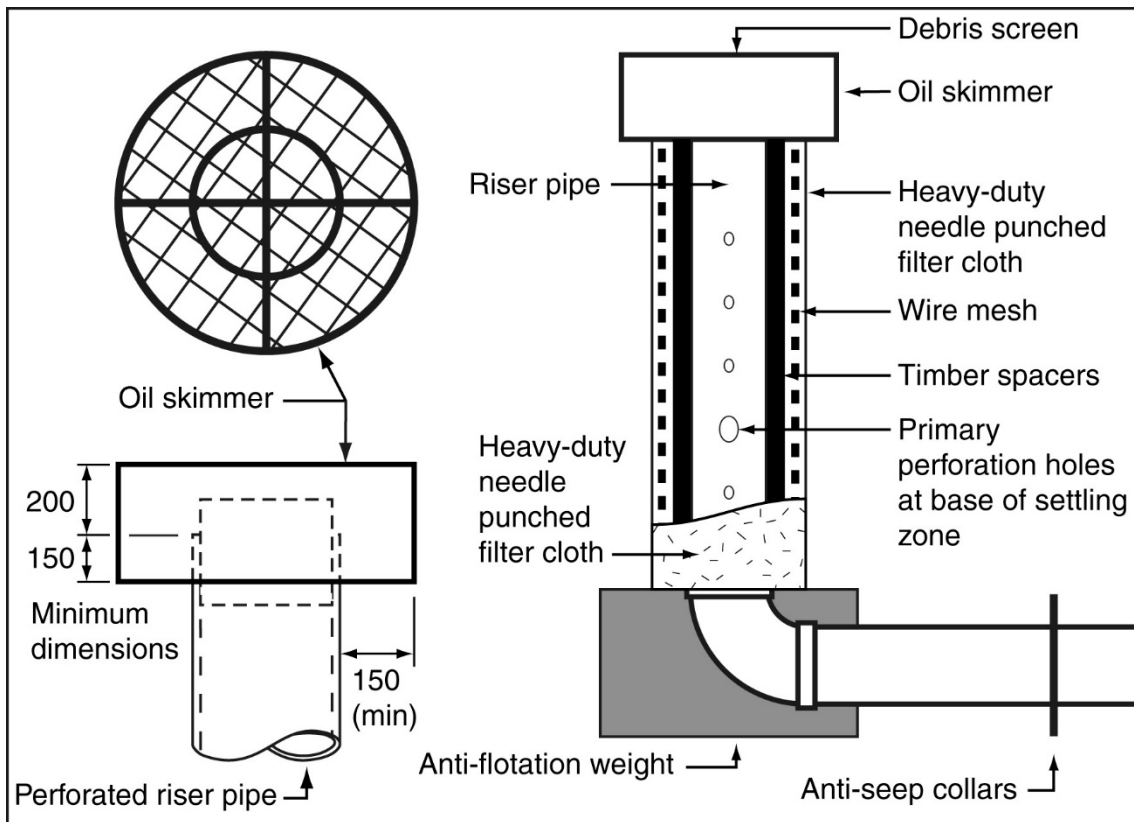

Figure B30 – Typical details of riser pipe outlet with fabric filter

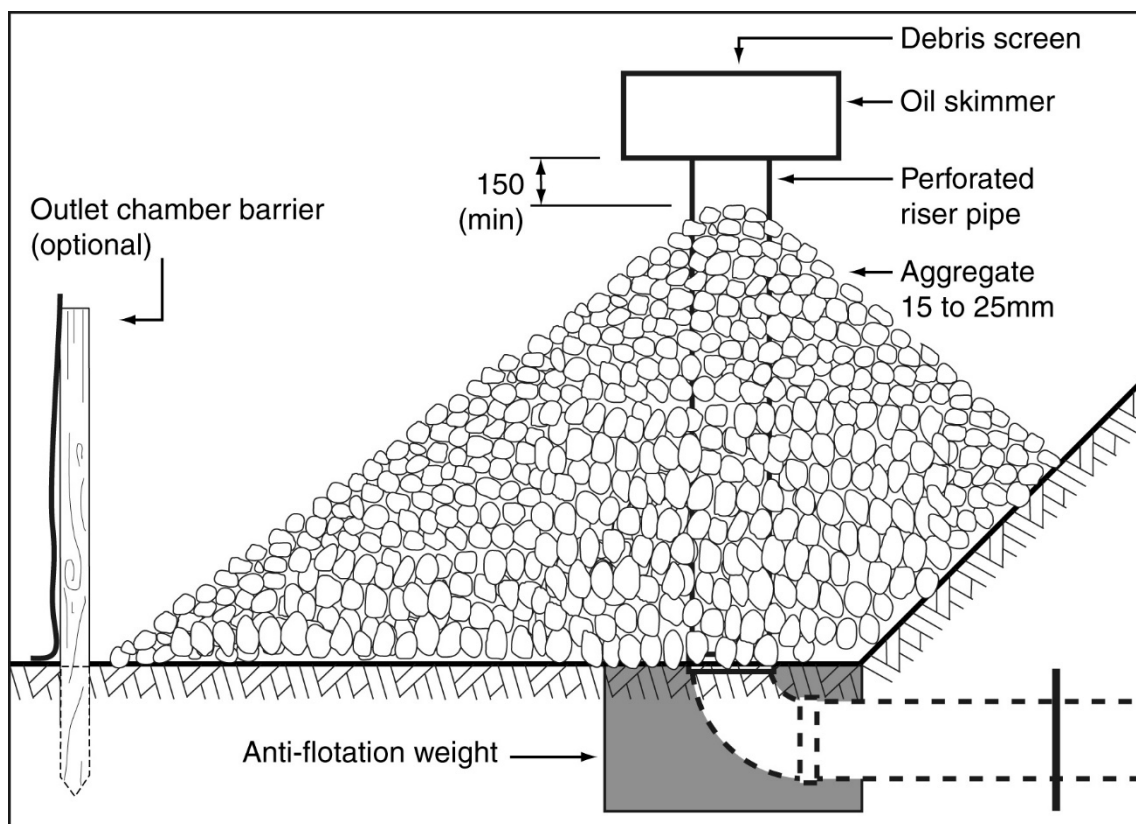

Figure B31 – Typical details of riser pipe outlet with aggregate filter

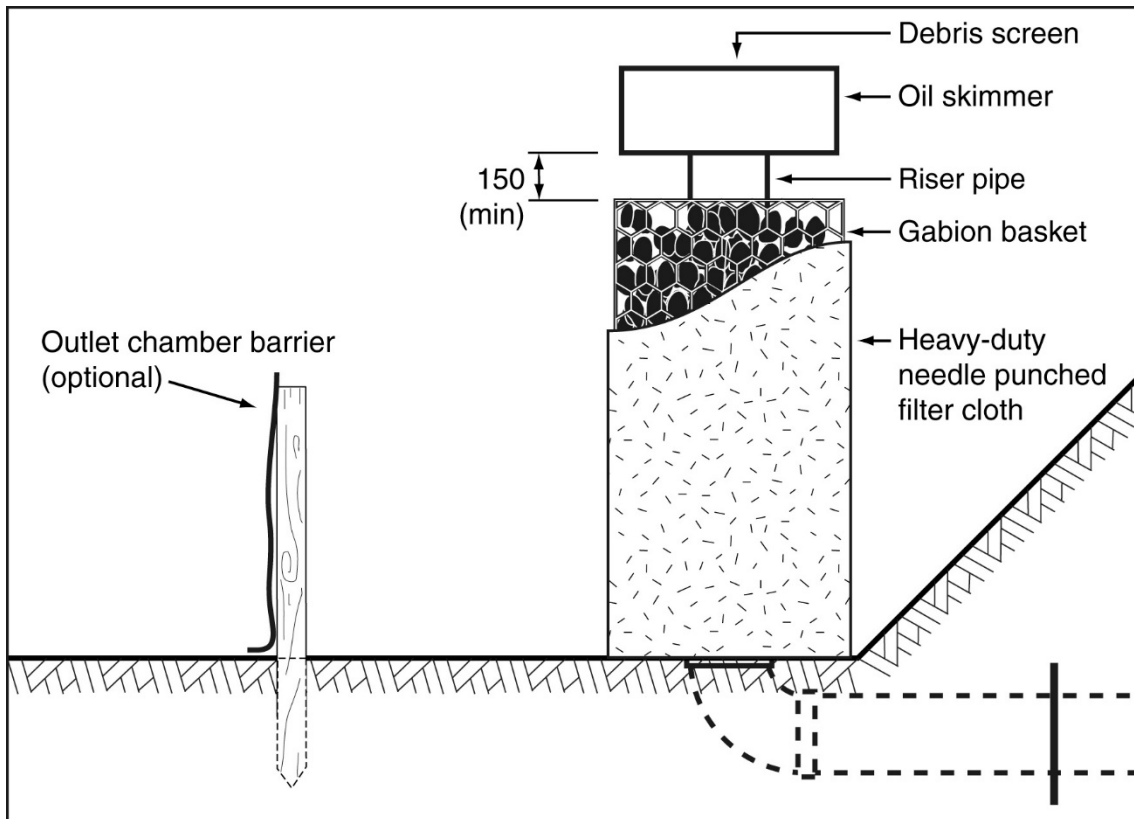

Figure B32 – Typical details of riser pipe outlet with rock-filled gabion baskets

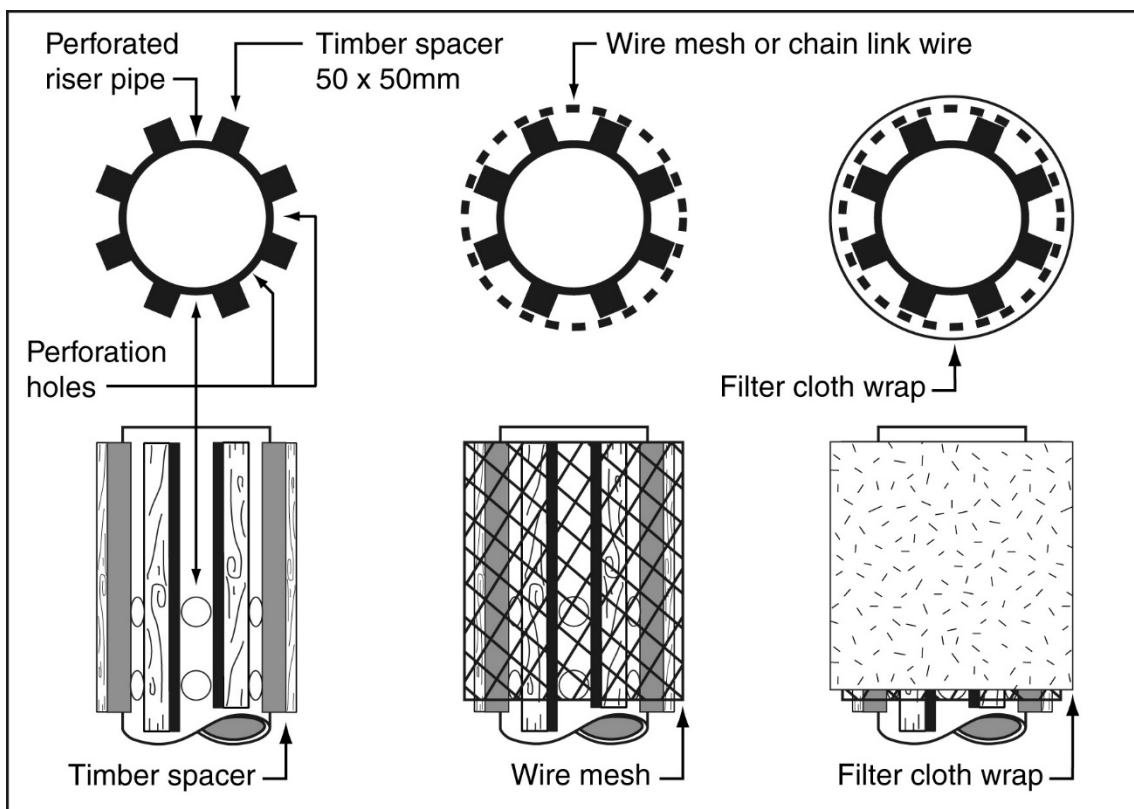

Figure B33 – Typical assembly of riser pipe with filter fabric

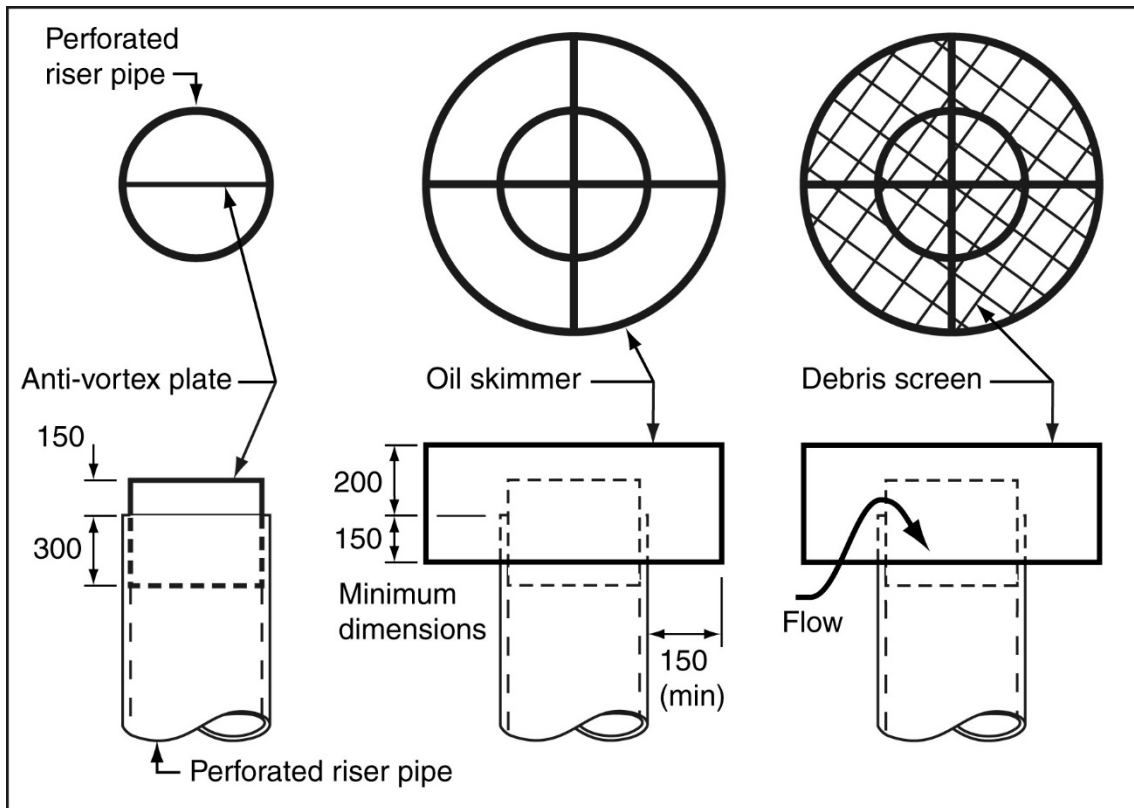

Figure B34 – Typical details of anti-vortex plate, oil skimmer and debris screen

Step 11: Design the emergency spillway

The minimum design storm for sizing the emergency spillway is defined in Table B35.

Table B35 – Recommended design standard for emergency spillways on temporary sediment basins^[1]

Design life	Minimum design storm ARI
Less than 3 months operation	1 in 10 year
3 to 12 months operation	1 in 20 year
Greater than 12 months	1 in 50 year
If failure is expected to result in loss of life	Probable maximum flood (PMF)

[1] Alternative design requirements may apply to Referable Dams in accordance with state legislation, or as recommended by the Dam Safety Committee (ANCOLD 2000a & 2000b)

The crest of the emergency spillway is to be at least:

- 300 mm above the primary outlet (if included)
- 300 mm below a basin embankment formed in virgin soil
- 450 mm below a basin embankment formed from fill.

In addition to the above, design of the emergency spillway must ensure that the maximum water level within the basin during the design storm specified in Table B35 is at least:

- 300 mm below a basin embankment formed from fill
- 150 mm plus expected wave height for large basins with significant fetch length (note; significant wind-generated waves can form on the surface of large basins).

The approach channel can be curved upstream of the spillway crest, but must be straight from the crest to the energy dissipater as shown in Figure B35. The approach channel should have a back-slope towards the impoundment area of not less than 2% and should be flared at its entrance, gradually reducing to the design width at the spillway crest.

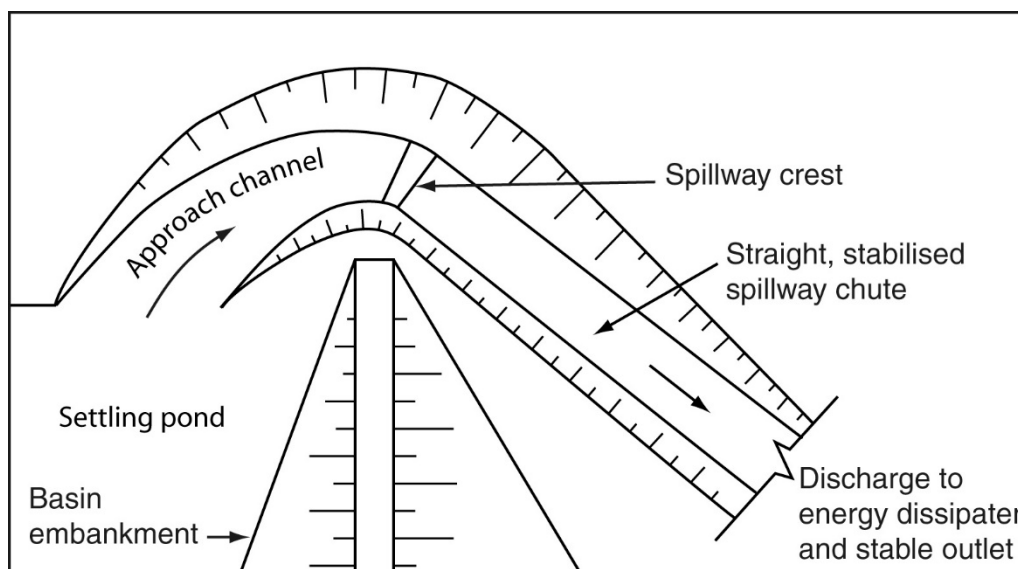

Figure B35 – Emergency spillway (plan view)

All reasonable and practicable efforts must be taken to construct the spillway in virgin soil, rather than within a fill embankment. Placement of an emergency spillway within a fill embankment can significantly increase the risk of failure.

Anticipated wave heights may be determined from the procedures presented in the *Shore Protection Manual* (Department of the Army, 1984).

The hydraulic design of sediment basin spillways (Figure B36) is outlined in Section A5.4 of Appendix A – *Construction Site Hydrology and Hydraulics*.

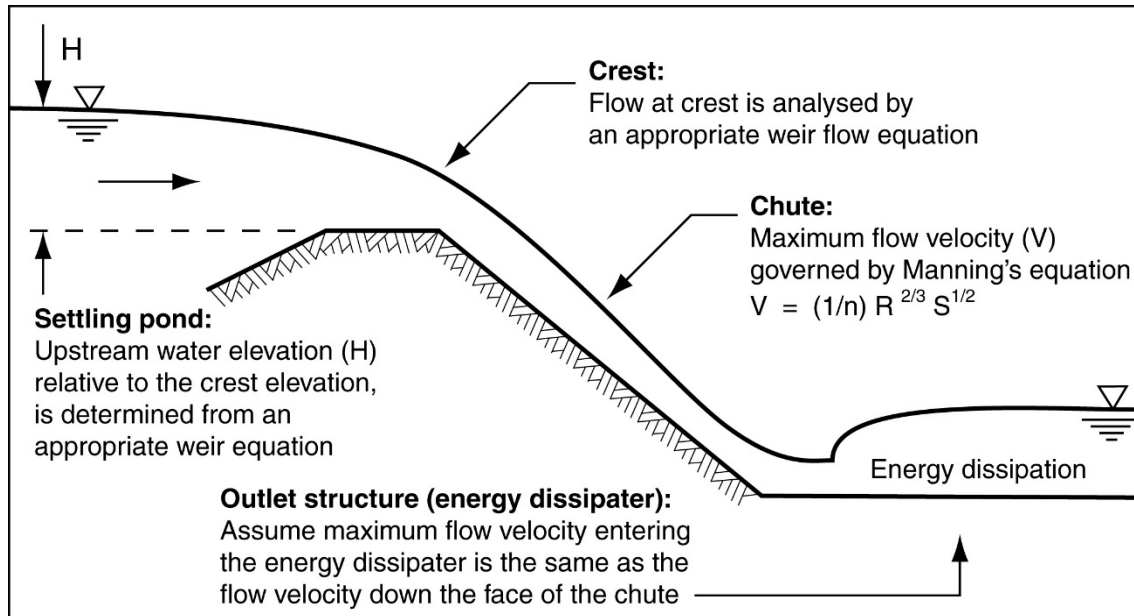

Figure B36 – Hydraulics of sediment basin spillways

The downstream face of the spillway chute may be protected with concrete, rock, rock mattresses, or other suitable material as required for the expected maximum flow velocity. Grass-lined spillway chutes are generally not recommended for sediment basins due to their long establishment time and relatively low scour velocity.

Recommended freeboard down the spillway chute is 300 mm.

Technical Note B6 – Design of rock chutes

Care needs to be taken to ensure that flow passing through voids of the crest of a rock or rock mattress spillway does not significantly reduce the basin's peak water level, or cause water to discharge down the spillway before reaching the nominated spillway crest elevation.

Discussion:

Unlike permanent stormwater treatment ponds and wetlands, construction site sediment basins are **not** designed to allow high flows to bypass the basin. Even if the basin is hydraulically full, sediment-laden stormwater runoff should continue to be directed through the basin. This allows the continued settlement of coarse-grained particles contained in the flow. Thus a side-flow channel does not need to be constructed to bypass high flow directly to the spillway.

Step 12: Determine the overall dimensions of the basin

If a *Sediment Basin* is constructed with side slopes of say 1:3 (V:H), then a typical basin may be 5 to 10 m longer and wider than the length and width of the settling pond determined in Step 6. It is important to ensure the overall dimensions of the basin can fit into the available space.

The minimum recommended embankment crest width is 2.5 m, unless justified by hydraulic/geotechnical investigations.

Where available space does not permit construction of the ideal sediment basin, then a smaller basin may be used; however, erosion control and site rehabilitation measures must be increased to an appropriately higher standard to compensate. **If the basin's settling pond surface area/volume is less than that required in Step 6, then the basin must be considered a Type 2 or Type 3 sediment control system.**

Equations B39 to B42 (over page) can be used to determine the outer dimensions of the settling pond given a required storage volume (or vice-versa) for various geometric shapes.

Volume calculations for prismatic shapes:

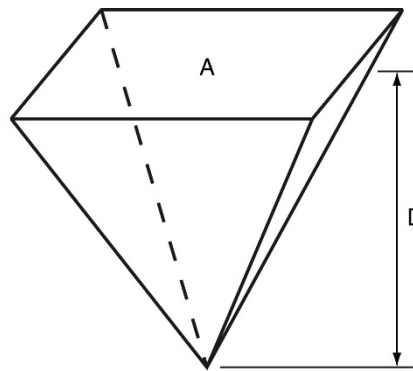
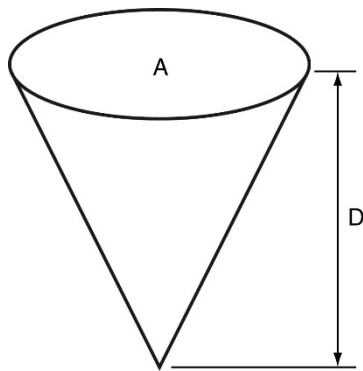

Volume (Eqn B39) =

$$V = (1/3).A.D$$

where:

V = volume [m³]

A = top surface area [m²]

D = depth of volume [m]

Volume (Equation B40) =

$$V = (1/3).W.(L - B).D + (1/2).W.B.D$$

where:

W = width of top surface [m]

L = length of top surface [m]

B = width of bottom edge [m]

D = depth of volume [m]

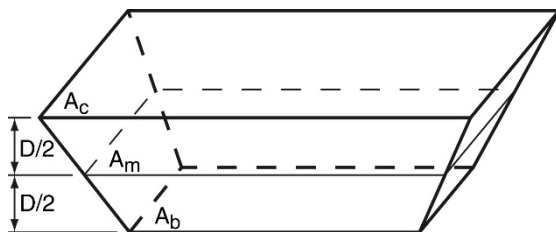
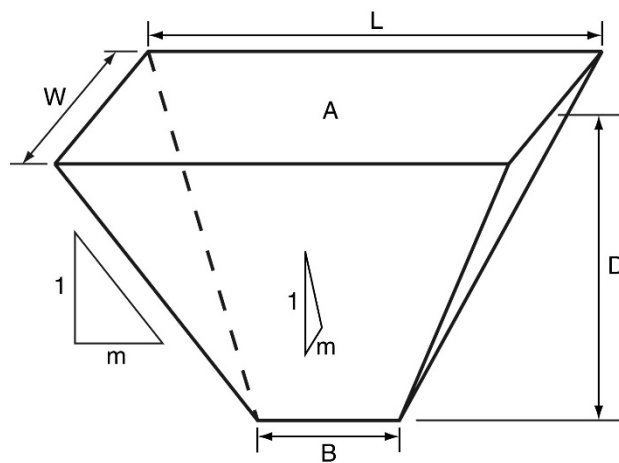

Simpson's Rule (Equation B41):

$$V = (D/6).(A_c + 4.A_m + A_b)$$

where:

D = depth of volume [m]

A_c = surface area at top of volume [m²]

A_m = surface area at mid depth [m²]

A_b = surface area at base of volume [m²]

Estimation of required basin depth (D) given pond surface area (A_s) and bank slope (m) (Equation B42)

$$D \approx \frac{-A_s + \sqrt{A_s^2 + 2.P.m.V}}{P.m}$$

where:

P = circumference of the base of the volume [m]

V = required basin volume [m³]

m = constant bank slope around the volume

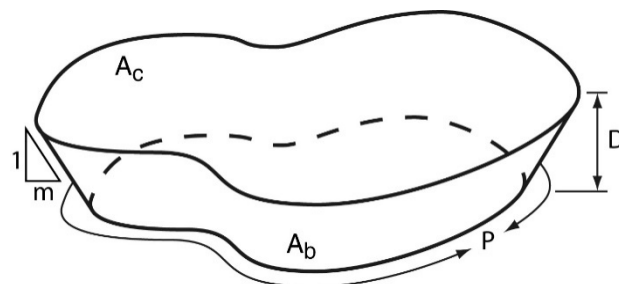

Step 13: Locate maintenance access (de-silting)

Sediment basins can either be de-silted using long-reach excavation equipment operating from the sides of the basin, or by allowing machinery access into the basin. If excavation equipment needs to enter directly into the basin, then it is better to design the access ramp so that trucks can be brought to the edge of the basin, rather than trying to transport the sediment to trucks located at the top of the embankment. Thus a maximum 1:6 (ideally 1:10, V:H) access ramp will need to be constructed.

If the sediment is to be removed from the site, then a suitable sediment drying area should be made available adjacent to the basin, or at least somewhere within the basin's catchment area.

Step 14: Define the sediment disposal method

Trapped sediment can be mixed with on-site soils and buried, or removed from the site. If sediment is removed from the site, then it should be de-watered prior to disposal. De-watering must occur within the catchment area of the basin.

If a coagulant or flocculant has been used in the treatment of runoff within the basin, guidance should be sought from the chemical supplier on the requirements for sludge removal or placement to ensure that any residual chemical bound to soil particles is managed appropriately and in accordance with the regulating authority requirements.

Step 15: Assess need for safety fencing

Construction sites are often located in publicly accessible areas. In most cases it is not reasonable to expect a parent or guardian of a child to be aware of the safety risks associated with a neighbouring construction site. Thus fencing of a sediment basin is usually warranted even if the basins are located adjacent to other permanent water bodies such as a stream, lake, or wetland.

Responsibility for safety issues on a construction site ultimately rests with the site manager; however, each person working on a site has a duty of care in accordance with the state's work place safety legislation. Similarly, designers of sediment basins have a duty of care to investigate the safety requirements of the site on which the basin is to be constructed.

Step 16: Define the rehabilitation process for the basin area

The Erosion and Sediment Control Plan (ESCP) needs to include details on the required decommissioning and rehabilitation of the sediment basin area. Such a process may involve the conversion of the basin into a component of the site's permanent stormwater treatment network.

On subdivisions and major road works, construction site sediment basins often represent a significant opportunity for conversion into either: a detention/retention basin, bioretention system, wetland, or pollution containment system. In rural areas, basins associated with road works are often constructed within adjacent properties where they remain under the control of the landowner as permanent farm dams.

Technical Note B7 – Pollution containment systems

Technically, pollution containment systems are not part of the stormwater treatment network because treatment of the pollutant does not occur on-site. Instead, the pollutant (usually liquid spills from traffic accidents) is contained within these devices for later removal and treatment and/or disposal off-site.

Detention/retention basins and wetlands can operate as pollution containment systems by modifying the outlet structure such that emergency services (e.g. EPA or fire brigade) can manually shut-off the outlet (usually with stop boards or sandbags) thus containing any pollutants within the basin.

Sediment basins that are to be retained or transformed into part of the permanent stormwater treatment system, may be required to pass through a staged rehabilitation process as outlined in tables B33 and B34.

In those circumstances where it is necessary to temporarily protect newly constructed permanent stormwater treatment devices (such as bioretention systems and wetlands) from sediment intrusion, there are a number of options as outlined in Table B38.

With appropriate site planning and design, the protection of these permanent stormwater treatment devices is generally made easier if the sediment basin is designed with a pre-treatment inlet pond as discussed in Step 9. The pre-treatment pond can remain as a coarse sediment trap during the maintenance and building phases, thus protecting the newly formed wetland or bioretention system located within the basin's main settling pond.

Continued operation of the sediment basin during the building phase of subdivisions (i.e. beyond the specified maintenance phase) is an issue for negotiation between the regulatory authority and the land developer on a case-by-case basis. Ultimately, the responsibility for the achievement of specified (operational phase) water quality objectives rests with the current land owner or asset manager.

During the construction, decommissioning, rehabilitation, or reconstruction of a sediment basin, the basin area including settling pond, embankment and spillway, must be considered a 'construction site' in its own right. Thus, these works must comply with the drainage, erosion, and sediment control standards outlined in Chapter 4 – *Design standards and technique selection*. This means that appropriate temporary sediment control measures will be required down-slope of the sediment basin during its construction and decommissioning.

Upon decommissioning of a sediment basin, all water and sediment must be removed from the basin prior to removal of the embankment (if any). Any such material, liquid or solid, must be disposed of in a manner that will not create an erosion or pollution hazard.

Table B36 – Modification of basin during construction phase (site not including a building phase)

Stage 1	Construction phase	<ul style="list-style-type: none"> • Basin operated as per the specifications of the ESCP and as required within this appendix to satisfy a Type 1 sediment trap. • If an alternative, permanent, outlet structure is to be constructed prior to stabilisation of the up-slope catchment area, then this outlet structure must not be made operational if it will adversely affect the required operation of the sediment basin. • The permanent stormwater treatment features (e.g. vegetation and filtration media) must be appropriately protected from the adverse effects of sediment runoff in accordance with the requirements of the proposed asset manager. It is usually considered insufficient to protect filter media by surrounding it with a Type 3 sediment control system. • The basin must not be modified to a Type 2 sediment trap (i.e. a sediment basin with surface area and/or volume less than that required by this appendix) until the assessed sediment runoff rate from the contributing catchment is less than the trigger value for a Type 1 sediment trap (refer to Tables 4.5.1 and 4.5.2, Chapter 4, as appropriate). • The basin must not be decommissioned until all up-slope site stabilisation measures have been implemented and are appropriately working to control soil erosion and sediment runoff in accordance with the specified ESC standard. This clause may require the basin to be fully operational during part of the maintenance and operational phases.
Stage 2	Maintenance phase	<ul style="list-style-type: none"> • Until such conditions are achieved where the basin can be decommissioned (as per above) the permanent stormwater treatment features (e.g. vegetation and filter media) must be appropriately protected from the adverse effects of sediment runoff in accordance with the requirements of the proposed (operational phase) asset manager. It is usually considered insufficient to protect filter media by surrounding it with a Type 3 sediment control system. • Upon suitable conditions being achieved within the basin's catchment area, the operational features of the permanent stormwater treatment system are to be made fully operational (i.e. maintenance and/or reconstruction as required).

Table B37 – Modification of basin during construction phase followed by a building phase

Stage 1	During construction phase	<ul style="list-style-type: none"> Basin operated as per the specifications of the ESCP and as required within this appendix to satisfy a Type 1 sediment trap. If an alternative, permanent, outlet structure is to be constructed prior to stabilisation of the up-slope catchment area, then this outlet structure must not be made operational if it will adversely affect the required operation of the sediment basin. The permanent stormwater treatment features (e.g. vegetation and filtration media) must be appropriately protected from the adverse effects of sediment runoff in accordance with the requirements of the proposed asset manager. It is usually considered insufficient to protect filter media by surrounding it with a Type 3 sediment control system. The basin must not be modified to a Type 2 sediment trap (i.e. a sediment basin with surface area and/or volume less than that required by this appendix) until the assessed sediment runoff rate for the contributing catchment is less than the trigger value for a Type 1 sediment trap (refer to Tables 4.5.1 and 4.5.2, Chapter 4, as appropriate). The basin must not be decommissioned until all up-slope site stabilisation measures have been implemented and are appropriately working to control soil erosion and sediment runoff in accordance with the specified ESC standard. This clause may require the basin to be fully operational during part of the maintenance and operational phases.
Stage 2	Maintenance phase whether pre, or during the building phase	<p>Default condition:</p> <ul style="list-style-type: none"> The permanent stormwater treatment features of the rehabilitated basin must not be made operational until all up-slope site stabilisation measures have been implemented and are appropriately working to control soil erosion and sediment runoff in accordance with the specified ESC standard. Until such conditions are achieved where the basin can be decommissioned, the permanent stormwater treatment features (e.g. vegetation and filtration media) must be appropriately protected from the adverse effects of sediment runoff in accordance with the requirements of the proposed asset manager. It is usually considered insufficient to protect filter media by surrounding it with a Type 3 sediment control system. <p>Alternative operational condition:</p> <ul style="list-style-type: none"> Upon the approval of the proposed (operational phase) asset manager and the regulatory authority, the newly constructed permanent stormwater treatment features of the basin may be made operational if such actions do not prevent the site from operating at the required sediment control standard.
Stage 3	Immediately prior to completion of maintenance phase	<ul style="list-style-type: none"> Upon suitable conditions being achieved within the basin's catchment area, the operational features of the permanent stormwater treatment system are to be made fully operational (i.e. maintenance and/or reconstruction as required).

Table B38 – Options for the temporary protection of newly constructed permanent stormwater treatment devices

Options	Comments
On-line operation with no protection or coarse sediment controls	<ul style="list-style-type: none"> • Generally requires the full reconstruction of the permanent stormwater treatment device at the end of the maintenance period. • Plant establishment within the wetland or bioretention system must be delayed until sediment intrusion is minimised. • May require significant maintenance or full reconstruction following completion, or near completion, of the building phase. • This option can provide good water quality controls and protection of receiving waters during the building phase.
On-line operation with placement of temporary surface protection over filter media	<ul style="list-style-type: none"> • Filter media typically covered by heavy-duty filter cloth and minimum 200 mm layer of earth or sacrificial filter media. • Rehabilitation of the permanent stormwater treatment device at the end of the maintenance period is cheaper due to protection of the filter media. • Plant establishment within the wetland, bioretention, or biofiltration system must be delayed until sediment intrusion is basically under control. • This option can provide moderate to high water quality controls and protection of receiving waters during the building phase.
On-line operation with temporary up-slope coarse sediment trap	<ul style="list-style-type: none"> • Often the preferred option when the sediment basin includes a pre-treatment inlet pond (refer to Step 9). • Adequate protection of the filter media is generally only achieved through the use of a Type 2 sediment control system. • On bioretention/biofiltration systems, protection of the filter media can be improved by placing <i>Filter Tubes</i> or a <i>Filter Tube Dam</i> down-slope of the coarse sediment trap. The filter tubes may be allowed to lie between the newly established plants, directly over the filter media. • In high clay content soils, it may still be necessary to rehabilitate the permanent stormwater treatment device at the end of the maintenance and building periods. • This option may allow early establishment of plants within the wetland or bioretention system. • This option can provide good water quality controls and protection of receiving waters during the building phase.
Off-line operation (full bypassing)	<ul style="list-style-type: none"> • No water quality benefit is obtained from the newly constructed permanent stormwater treatment devices. • Generally this is the lowest cost option with respect to the construction and maintenance of the permanent stormwater treatment system; however, overall site costs can be high due to the need to maintain separate sediment control measures (i.e. basins) during the maintenance and building phases. • On bioretention/biofiltration systems, higher water quality benefits can be achieved by integrating <i>Filter Tubes</i> into the flow bypass system, thus allowing limited treatment of those flows entering the <i>Filter Tubes</i>. The <i>Filter Tubes</i> are likely to be subject to blockage by coarse sediment unless their inlets are appropriately elevated above the level of expected coarse sediment deposition.

Step 17: Define the basin's operational procedures

This design step provides guidance on how to provide appropriate information to the basin operator, as part of the basin's *Operational Procedures*, on how the operator should review the basin's performance, and how to take appropriate actions to improve the basin's performance.

(i) Preparing the 'operating procedures' for basins

The operator of a sediment basin must be provided with a set of recommended *Operating Procedures* for that basin that have been prepared, or at least endorsed by, the designer of the basin. These operating instructions must include, as a minimum, the following information:

- decant water quality objectives
- description of proposed chemical treatment of the basin, including minimum Jar Testing performance requirements (refer to Section B3(V))
- performance assessment procedures
- guidance on corrective measures based on water quality monitoring outcomes
- description of de-watering 'triggers', including triggers for the temporary shut-off of the decant system in the event of poor water quality (applicable to Type A basins)
- description of de-silting 'triggers'
- description of those circumstances and/or weather conditions that would trigger the de-watering of the basin prior to an imminent storm
- For Type C basins: description of the 'triggers' for the chemical treatment of Type C basins (or the conversion of Type C basins to a Type B or Type D operation).

Table B39 provides an overview of the typical operational conditions of the various types of sediment basins.

Table B39 – Typical operational conditions of various *Sediment Basins*

Attribute	Type A	Type B	Type C	Type D
Desirable basin water level before a storm	Fully drained settling zone	Fully drained settling zone	Ideally fully drained, but may retain water	Fully drained
Allowable inter-storm basin water level during specific seasonal or weather conditions	May retain water between storms, but <u>must</u> be de-watered prior to any storm that is likely to produce runoff	May retain water between storms, but under certain conditions, <u>must</u> be de-watered prior to an imminent storm. These 'conditions' may include a specified wet season, or when weather forecasting predicts a significant storm event.		May retain water between storms, but <u>must</u> be de-watered prior to any storm that is likely to produce runoff
De-watering system	Floating	N/A	Free-draining	Pump, siphon or floating decant
Chemical treatment	Automatic	Automatic	None	Automatic or manual dosing

(ii) Water quality objectives

Prior to the discharge of water from a sediment basin, it is essential for the water quality to comply with all specified water quality objectives (e.g. water pH, suspended

sediment and/or turbidity). In the absence of state guidelines, the recommended water quality standard for waters released from sediment basins is presented in Table B40.

Table B40 – Recommended discharge standard for de-watering operations

Site conditions	Long-term discharge water quality standard
Default discharge water quality objective for Type A and Type B sediment basins	90 percentile total suspended solids (TSS) concentration not exceeding 50 mg/L.
Desired discharge water quality of free draining sediment basins (e.g. free draining Type C basins)	Take all reasonable and practicable measures to operate and/or modify the basin to achieve a 90 percentile total suspended solids concentration not exceeding 50 mg/L.
Post-storm de-watering of sediment basins (all basin types)	90 percentile total suspended solids (TSS) concentration not exceeding 50 mg/L.
All basins, all circumstances	Water pH in the range 6.5 to 8.5

Whenever possible, water samples collected from the sediment basin must be tested in a laboratory before discharge to prove that the suspended solid content is below recommended level. It is strongly recommended that sufficient water testing is conducted in order to enable a site-specific calibration between suspended solids concentrations (mg/L) and NTU turbidity readings. This would allow utilisation of the turbidity meters to determine when water quality is likely to have reached the equivalent of 50 mg/L.

In order to develop a **site-specific** relationship between suspended solids concentrations (mg/L) and NTU, there should be an absolute minimum number of five water samples (ideally 9-plus), all in the range of 20 – 150 mg/L. If the samples have a wider range of suspended sediments, such as 10 – 2000 mg/L, then the resulting relationship will be less reliable.

In the absence of a site-specific relationship, Table B41 is presented as an alternative NTU-based water quality standard for sediment basins.

Table B41 – Alternative discharge standard for de-watering operations

Site conditions	Long-term discharge water quality standard
Default discharge water quality objective for Type A and Type B sediment basins	90 percentile Nephelometric Turbidity Units (NTU) reading not exceeding 100, and 50 percentile NTU reading not exceeding 60.
Desired discharge water quality of free draining sediment basins (e.g. free draining Type C basins)	Take all reasonable and practicable measures to operate and/or modify the basin to achieve a 90 percentile Nephelometric Turbidity Units (NTU) reading not exceeding 100, and 50 percentile NTU reading not exceeding 60.
Post-storm de-watering of sediment basins (all basin types)	90 percentile Nephelometric Turbidity Units (NTU) reading not exceeding 100, and 50 percentile NTU reading not exceeding 60.
All basins, all circumstances	Water pH in the range 6.5 to 8.5

If the basin's operation is managed through the use of a specified or determined NTU reading, then water samples must still be taken daily during de-watering operations to determine the total suspended solids (TSS) concentration. Both the TSS and NTU values must be recorded and reported as appropriate.

(iii) Use of coagulants and flocculants

The appropriate chemical treatment of a Sediment Basin is required if the potential release water does not satisfy the specified water quality objectives. A discussion on use of coagulants and flocculants is provided in Section B3 of this appendix.

(iv) De-watering procedures

Unless specifically allowed by the regulating authority, Type A and Type D basins must be fully drained after each storm event to provide the necessary storage volume for subsequent storms (refer to Table B39). Authorities may stipulate a period of the year (typically the dry season) when Type A basins can retain water after storm events for the purpose of on-site usage; however, these basins must be drained prior to any storm that is likely to produce significant (i.e. measurable) basin inflows.

In the case of a Type A basin, the term 'fully drained' means the basin has drained to the bottom rest position of the floating decent system.

Technical Note B8 – Recommended operational procedure for the retention of water within Type A basins

Water should only be retained in a Type A basin (post storm) upon the agreement of the state, and only during those month recognised by the state as the 'dry season', and only if there is **good** reason to expect that the basin capacity will not be exceeded by a forecast rainfall event.

If, prior to further rainfall, the water level has not been lowered to the bottom of the settling zone, the valve should be opened, provided that the water quality is within the discharge limits. This process should occur well in advance of rainfall occurring, as de-watering will take some time.

Theoretically, Type B and Type C basins may be full, or partially-full, immediately prior to a storm, but it is still desirable for these basins to be fully drained prior to accepting further inflows in order to optimise the basin's overall performance.

Technical Note B9 – Recommended operational procedure for the retention of water within Type B basins

The basin shall be fully de-watered after rainfall events during the wet season (if a defined wet season exists). The basin shall also be fully de-watered if there is **good** reason to expect that the basin's remaining (i.e. pre de-watering) capacity will be exceeded by forecast rainfall.

If the long-term operation of Type C basins within a given region identifies the presence of fast and efficient settling sediments, and good water quality outcomes, then the low-flow drainage system can be ignored/decommissioned, and the basins can be operated as a 'wet ponds'.

Even if soil conditions satisfy the initial selection of a Type C basin, this does not guarantee that the water quality achieved by the basin will satisfy the required environmental objectives. If a Type C basin fails to regularly achieve the required water quality objectives, then the basin may need to be converted to, or operated as, a Type B or Type D basin in order to satisfy specified water quality objectives.

The operation of Type D basins is similar to Type A basins. In ideal circumstances, the treated water can be retained within these basins for use on site, but the basins must be drained prior to any storm that is likely to produce significant (i.e. measurable) basin inflows.

(v) De-silting procedures

An appropriately marked (e.g. painted) de-silting marker post must be installed in the basin to indicate the top of the sediment storage zone. The basin must be de-silted if the next storm is likely to cause the settled sediment to rise above this marker point, or if the settled sediment is already above this marker point.

Table B42 provides the recommended de-silting trigger points for sediment basins.

Table B42 – Recommended basin de-silting trigger points

Basin type	De-silting triggers
All basin types	<ul style="list-style-type: none"> If the next storm is likely to cause the settled sediment to rise above the nominated marker point. The settled sediment has exceeded 90% of the nominated sediment storage volume.
Type A basins	<ul style="list-style-type: none"> As above for all basins. The top of the settled sediment is less than 300 mm below the bottom rest position of the floating decant arms. <p><i>This means the basin should be de-silted <u>before</u> the settled sediment reaches the critical elevation of 200 mm below the decant arms (i.e. the theoretical top of the sediment storage zone).</i></p>

(vi) Performance assessment procedures

A performance review of should be carried out on all basins that utilise chemical treatment. For Type A and B basins, a performance report should be completed after each storm event that results in discharge from the basin. A template for a *Basin Performance Report* is provided in this section. This template has been prepared for Type A basins, but can be adapted to other types of sediment basins.

Although it is desirable for sediment basins to achieve the desired water quality standard during every storm, circumstances can exist that will cause uncontrolled discharges to exceed these standards. Due to the inherent complexity and variability of rainfall events, and variations in the performance of flocculants, it is possible for discharges above, say 50 mg/L, to occur. This of course does not necessarily make such discharges either lawful or unlawful. The resulting legal issues are complex and will likely vary from site to site.

Sediment basins are not designed to achieve a specific water quality; rather, they are designed to either capture and treat a specific volume of runoff, or to treat discharges up to a specified peak flow. A specific water quality cannot be guaranteed solely through the 'sizing' of the basin, but must be achieved in association with site-specific water quality management practices, such as those discussed above (Step 17). sediment basins cannot perform in an appropriate manner without the attentive input from suitably trained site personnel.

Irrespective of the circumstances, the operator should regularly inspect the critical design features of the basin, and should review the basin's performance against its design expectations. If a water quality failure is observed, then the operator should endeavour to take multiple samples during these releases to document the duration of such exceedances. Adjustments to the basin, and the basin's operation, should occur after each observed failure. The use of such adaptive management practices is critical to achieving the optimum performance of any sediment basin.

Being able to demonstrate that adaptive management practices are being implemented at the site is an important consideration noted by regulators when determining whether all things reasonable and practicable are being done to minimise sediment releases.

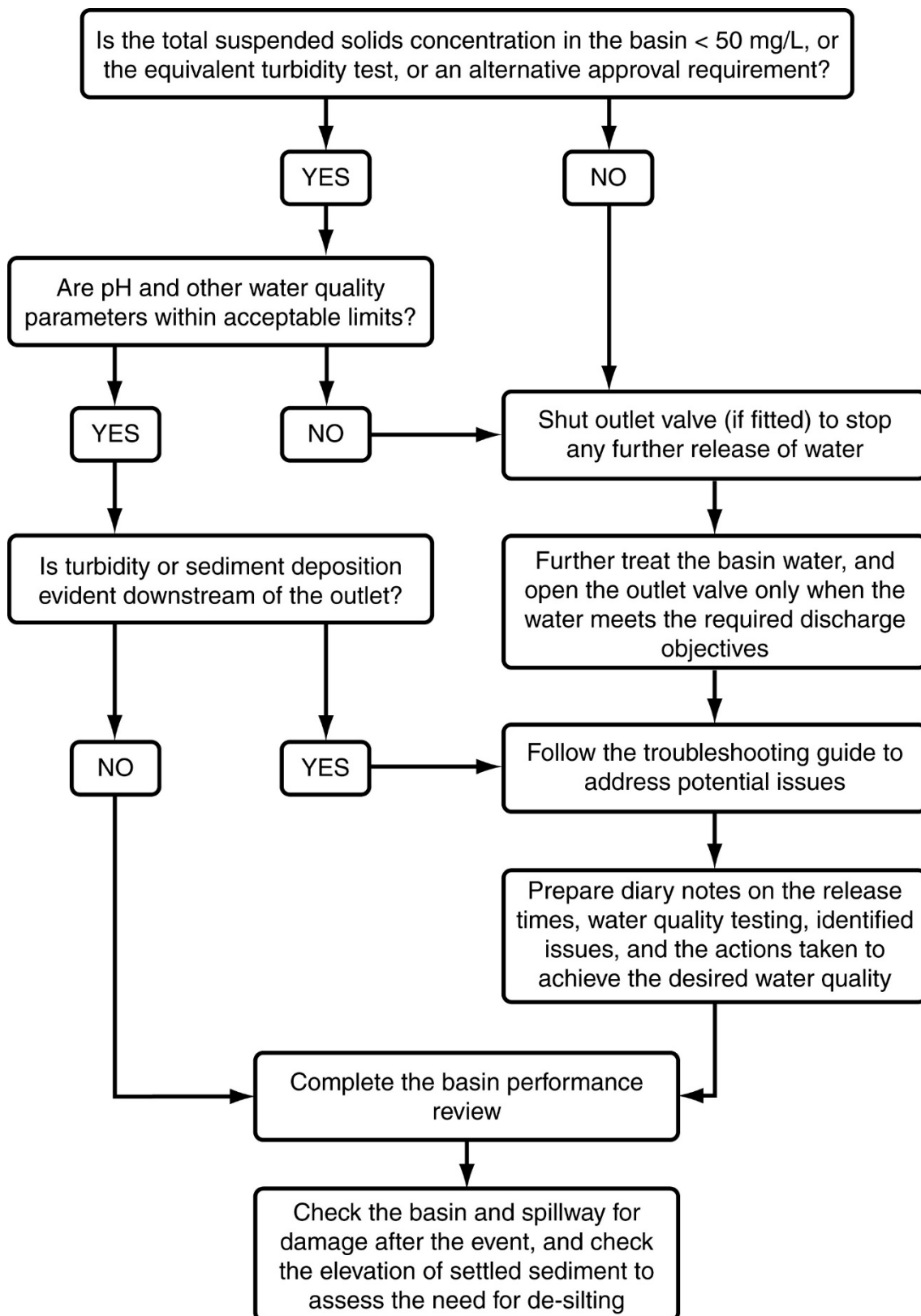

Figure B37 – Basin performance assessment process

(vii) Troubleshooting for Type A & B basins

Although all processes may have been followed in a basin design and construction, performance may not always meet expectations. Table B43 provides a list of potential issues, reasons for the issues and remediation actions that can be used to guide operators on how to improve basin performance.

Two critical items will typically be the cause for poor performance:

Chemical not working

Incorrect chemical
Incorrect dose rate
Lack of mixing and/or settling conditions

Not enough settling time in basin

Short-circuiting in main basin cell
Above design flow rate

Although the above items will be the common causes of performance issues, all items in the checklist should be assessed to determine any potential improvements to be made.

Table B43(a) – Type A and B basin troubleshooting

	Issue	Potential reason for issue	Proposed remediation action
Inflow channel	Channel/pipe overtopped	<ul style="list-style-type: none"> Channel/pipe undersized Rainfall event exceeded design capacity 	<ul style="list-style-type: none"> Check drain is constructed as per design If not an over-design event and drain is constructed as per design, review design
	Scour in channel	<ul style="list-style-type: none"> Lining not installed as per design Rainfall event exceeded design capacity 	<ul style="list-style-type: none"> Check drain is constructed as per design If not an over-design event and drain is constructed as per design, review design
	Chemical not mixing with inflow runoff in channel	<ul style="list-style-type: none"> Channel not well defined and runoff bypassing during low flows 	<ul style="list-style-type: none"> Formalise channel to ensure all flows achieve mixing with chemical
	Catchment bypassing channel	<ul style="list-style-type: none"> Upslope drainage not adequate 	<ul style="list-style-type: none"> Refer to ESCP on drainage required and modify if required to ensure the design catchment enters basin
	Lateral inflow to main basin cell	<ul style="list-style-type: none"> Runoff not conveyed back to single inflow point Runoff on side of basin cannot be conveyed back to inflow point due to levels 	<ul style="list-style-type: none"> Construct drain to convey runoff back to inflow point If drain cannot be constructed due to levels, form bund on edge of basin to limit lateral inflow
	Flow restricted through baffle too much	<ul style="list-style-type: none"> Weave too tight 	<ul style="list-style-type: none"> Replace with material as per specification

Table B43(b) – Type A and B basin troubleshooting (continued)

Issue		Potential reason for issue	Proposed remediation action
Chemical	Coagulant or flocculant not working	<ul style="list-style-type: none"> No dosing occurred Poor mixing Incorrect dose rate Incorrect chemical Other site constraints such as pH and Total Alkalinity 	<ul style="list-style-type: none"> Refer to dosing system Ensure defined inlet and mixing is promoted as it enters forebay Test raw water with chemical and dose rates as per testing process to determine required augmentation
	No dosing	<ul style="list-style-type: none"> System not operated or maintained as per suppliers specification System/componentry failure Dose line/dispensing material blocked 	<ul style="list-style-type: none"> Refer to suppliers specification or contact supplier of dosing system Clean dose line and modify line to minimise potential for repeat blockage
Dosing system	Incorrect dose rate	<ul style="list-style-type: none"> Incorrect parameters input to dosing system or placement of chemical dispenser Additional runoff pumped or directed to basin Insufficient chemical available for runoff volume that occurred 	<ul style="list-style-type: none"> Refer to suppliers specification or contact supplier of dosing system Review inflow catchment and determine if in accordance with design and rectify if required Ensure enough chemical is available for expected rain events
	Sediment being resuspended	<ul style="list-style-type: none"> Sediment built up on floor of basin No dissipation at inlet to forebay 	<ul style="list-style-type: none"> Remove sediment from forebay Provide dissipation to inlet to forebay
Level spreader	Concentrated flow over level spreader	<ul style="list-style-type: none"> Level spreader not level 	<ul style="list-style-type: none"> Reshape level spreader to get level or mount aluminium section to get within tolerance
	Scour on backside of level spreader	<ul style="list-style-type: none"> Batter Slope into main basin too steep Lining to backside of level spreader not adequate 	<ul style="list-style-type: none"> Flatten batter slope if possible Armour batter
Settling pond	Flow short circuiting in main basin	<ul style="list-style-type: none"> Level spreader not level Shape of basin is concentrating flow 	<ul style="list-style-type: none"> Fix level spreader Install permeable baffles to promote uniform flow
	Erosion on side of basin batters	<ul style="list-style-type: none"> Wind action Erosive soils 	<ul style="list-style-type: none"> Armour/protect batters of basin

Table B43(c) – Type A and B basin troubleshooting (continued)

	Issue	Potential reason for issue	Proposed remediation action
In-line baffles	Flow concentrating to one side of baffle	<ul style="list-style-type: none"> • Float failed on one side • Non-uniform weave of baffle 	<ul style="list-style-type: none"> • Review floats and weave to ensure uniform
	Flow conveyed over the top of the baffle	<ul style="list-style-type: none"> • Floats not adequate 	<ul style="list-style-type: none"> • Install more floats
	Flow restricted through baffle too much	<ul style="list-style-type: none"> • Weave too tight 	<ul style="list-style-type: none"> • Replace with material as per specification
	Flow passes through baffle too quick providing little benefit	<ul style="list-style-type: none"> • Weave too open 	<ul style="list-style-type: none"> • Replace with material as per specification
Decant system	Decant sinks below water surface	<ul style="list-style-type: none"> • Not enough float • Weighting too much 	<ul style="list-style-type: none"> • Review float and weighting and rectify
	Decant raised above water level	<ul style="list-style-type: none"> • Not enough weighting 	<ul style="list-style-type: none"> • Review weighting and rectify
	Decants dropped on one-side	<ul style="list-style-type: none"> • Weighting not uniform • Stays not installed correctly 	<ul style="list-style-type: none"> • Review weighting and rectify • Install cable stays to keep float level while suspended
	Decants blocked	<ul style="list-style-type: none"> • Debris 	<ul style="list-style-type: none"> • Remove debris from decants inlets
	Decants concentrating flow in basin	<ul style="list-style-type: none"> • Single decant in the middle of the basin with high flow rate 	<ul style="list-style-type: none"> • Review design and parameters to ensure multiple decants across the width aren't required, and rectify
Emergency spillway	Concentrated flow on spillway	<ul style="list-style-type: none"> • Spillway not level 	<ul style="list-style-type: none"> • Level spillway
	Spillway too low	<ul style="list-style-type: none"> • Incorrect construction • Cut off wall not installed • Poor design 	<ul style="list-style-type: none"> • Check design and rectify
	Spillway too high with limited freeboard	<ul style="list-style-type: none"> • Incorrect construction • Rock placement incorrect • Poor design 	<ul style="list-style-type: none"> • Check design and rectify

(viii) Optimising critical basin features:

Type A and Type B basins incorporate several critical design features, each of which can influence the performance of the basin. Site operators and inspectors need to know when and how to repair or modify these design features in order to optimise the basin's performance. Table B44 provides an overview of these key design features and the issues that should be considered during a site inspection.

Table B44(a) – Optimising the performance of critical design features of Type A and Type B basins

Feature	Critical issues that could impact upon basin performance
Inflow channel	<ul style="list-style-type: none"> • Optimum basin performance is achieved when all inflows discharge into the forebay (i.e. no mid-basin inflows). • If multiple inflows exist, then multiple dosing systems will be required. • For piped inflows, the dosing points must be sufficiently upstream of the forebay to achieve sufficient mixing, but not excessive mixing. • For open channel inflows, the dosing points must also be sufficiently upstream of the forebay to achieve sufficient mixing. If insufficient mixing is occurring, then consider installing <i>Rock Check Dams</i> in the channel to increase the mixing. • If a flow-activated dosing system utilises sensors to measure water depth in the channel, then the channel will need to be constructed as per the dosing system requirements and tolerances.
Coagulant and flocculant	<ul style="list-style-type: none"> • The results of <i>Jar Testing</i> performed during the design of the basin can provide useful information if the performance of the flocculants fails to achieve the desired outcomes. • The dosing rates developed from <i>Jar Testing</i> should only be considered the 'starting point'. Consideration must be given to altering these dosing rates if the basin fails to achieve the required water quality objectives. • Refer to the Book 4 fact sheet on <i>Chemical coagulants and flocculants</i>.
Dosing system	<ul style="list-style-type: none"> • Active and passive dosing systems can be utilised with Type A and Type B basins. • Passive systems will require specialist advice to ensure the application method and maintenance regime in order to achieve the required outcomes. • Active dosing systems will typically be provided by suppliers as a proprietary product. Details of commonly used rainfall activated displacement system can be found in Auckland Regional Council's <i>Technical Publication 227</i>.
Forebay	<ul style="list-style-type: none"> • The forebay is used to dissipate the remaining inflow energy, and to aid in the mixing of flocculants. • High-energy inflows should be dissipated prior to entering the forebay. • If excessive turbulence exists within the forebay, then it can cause non-uniform flows over the level spreader. In such cases, an additional energy dissipation pit/chamber may need to be constructed between the inflow points and the forebay. Increasing the depth of the forebay can also help to reduce excessive turbulence. • Settled sediment should be removed from the forebay after storm events once the sediment level has reached approximately one quarter of the depth of the forebay.

Table B44(b) – Optimising the performance of critical design features of Type A and Type B basins

Feature	Critical issues that could impact upon basin performance
Level spreader	<ul style="list-style-type: none"> • The level spreader is a critical design feature that ensures uniform flow conditions exist within the main settling pond. • Irregularities in the level spreader, that may not be visible to the eye, can impact on the basin's overall performance. • Sediment deposits must be removed.
Settling pond	<ul style="list-style-type: none"> • The design of Type A and Type B basins is based on the construction of long, rectangular ponds. If the shape of the constructed pond varies from the ideal rectangle, then additional 'baffles' may be required to provide optimum flow conditions. • Observing the movement of the suspended sediment as it flows through a settling pond during a storm is a very good way of confirming the actual flow patterns of a constructed basin.
Baffles	<ul style="list-style-type: none"> • If baffles are installed within the settling pond, then it is important to observe the movement of water through the basin during storm events to ensure that these baffles are not causing large-scale eddies. • The performance of baffles can be modified by increasing or decreasing their permeability. Most baffles are effectively impermeable, but the benefits provided by permeable baffles should not be ignored, especially if uniform flow conditions do not currently exist. • If sediment re-suspension is occurring at the end of a baffle, then this may be reduced, in some cases, by increasing the baffle's permeability.
Floating decant system	<ul style="list-style-type: none"> • Minor modifications to the floating decant system can improve water quality outcomes during the early and later stages of a storm event; however, major modifications can potentially impact on the basin's performance during severe storms. • The most common modifications are (i) adjusting the bottom resting position of the lowest decant arm to reduce the release of settled sediment during the initial stages of a storm event, and (ii) modifying the number of active decant holes within each of the floating decant arms to alter the frequency of spillway overflows.
Emergency spillway	<ul style="list-style-type: none"> • If the overflow spillway is too narrow, then settled sediment can be re-suspended by the approaching supernatant flow and carried over the spillway. Such occurrences would result in a water quality failure. If such events are observed, then the width of the spillway may need to be increased. • Damage to overflow spillways most commonly occurs along the edges of the placed rock, either along the sides, or at the base of the spillway. It is NOT sufficient to only place rock (or other approved scour protection) along the base of the spillway. Any form of scour protection MUST extend up the sides of the spillway so as to fully contain the flow. • Suitable scour protection must also extend beyond the base of the spillway to avoid soil scour undermining the spillway. • Emergency overflow spillways must be constructed in a 'straight' alignment. Bending or curving a spillway can cause undesirable flow conditions, which can cause water to spill out of the spillway chute, or cause damage to the scour protection. • Energy dissipation down a spillway should NOT be improved/modified by placing large impact boulders at mid-points down the spillway.

BASIN PERFORMANCE REPORT

Site / basin identification: _____

Inspector: _____

Date / time: _____

Recent rainfall: _____

Water quality in basin: NTU: _____ pH: _____

Water level in basin: _____

	Issue Item	Potential Issue / Action Required (Y/N)	Comments/Action Undertaken
Inflow channel	Channel/pipe overtopped		
	Scour in channel		
	Chemical not mixing with inflow runoff		
	Catchment bypassing channel		
	Lateral inflow to main basin cell		
	Other		
Chemical & dosing	Chemical not working		
	No dosing		
	Incorrect dose rate		
	Other		
Fore bay	Sediment re-suspension		
	Other		
Level spreader	Concentrated flow over level spreader		
	Scour on backside of level spreader		
	Other		

Issue Item		Potential Issue / Action Required (Y/N)	Comments/Action Undertaken
Settling pond	Flow short circuiting in main basin		
	Erosion on side of basin batters		
	Other		
In-line baffles	Flow concentrating to one side of baffle		
	Flow conveyed over the top of the baffle		
	Flow restricted through baffle too much		
	Flow passes through baffle too quickly		
	Other		
Decant system	Decant sinks below surface		
	Decant raised above water level		
	Decant dropped on one side		
	Decant blocked		
	Decants concentrating flow in basin		
	Other		
Emergency spillway	Concentrated flow on spillway		
	Spillway too low		
	Spillway too high		
	Other		
Other General Comments			

Refer to troubleshooting guide (Table B43) for details on potential remediation for issue items.

B3 Coagulants and flocculants

The following is a *brief* discussion on the use of coagulants and flocculants to enhance the settling characteristics of sediment-laden water. Readers should refer to the associated Book 4 design fact sheet – ‘Chemical coagulants and flocculants’ for the *latest* technical information on the testing, selection and use of these products.

If any part of this Appendix B is found to be in contradiction with the technical data provided within the latest version of the ‘Chemical coagulants and flocculants’ fact sheet, then the information contained within the fact sheet shall take precedence.

(i) Clay and colloid solutions

Clay is the predominant particle type found in suspension within runoff captured by sediment basins. Clay particles are extremely small (less than 0.002 mm in size) and will not settle readily, if at all, even in still water.

When negatively charged clay particles and other colloids are suspended in water, they tend to repulse each other, much the same way similar poles of two magnets repel each other. The cumulative effect of the repulsion of a vast number of small particles prevents their aggregation into larger, heavier particles that would settle more readily.

Colloids (which includes clay particles) remain suspended in water because:

- Colloids have a very large surface area relative to their mass.
- Colloids typically have a static electric charge. Most colloidal particles in water have a negative charge.
- Static charge is a surface effect. The greater the surface area relative to the particle mass, the greater the effect of the charge.
- The mass of the particles is small enough that even Brownian motion is sufficient to ‘stir’ the clay particles in suspension.
- The colloids cannot agglomerate into larger particles and settle because they repel one another.

(ii) Coagulation

A coagulant is utilised to neutralise or destabilise the charge on clay or colloidal particles. Most clay particles in water are negatively charged and therefore any positive ion (cation) can be used as a coagulant.

Charge neutralisation in water can occur very rapidly; therefore, mixing is important for effective treatment of turbid water. After a short time, the ions form hydroxide gels which trap particles, or bridge between particles creating a floc that may settle.

There is always the possibility of overdosing with coagulants and building up excess positive charge, hence complying within the optimum dosage range is critical. When a cationic coagulant is overdosed, the clay and colloidal particles will take on a positive charge and repel each other and limit any settling. The dosage range of a coagulant will vary depending on site water chemistry. Different coagulants also have an optimum pH range over which they are effective and pH buffering may be required depending on the coagulant and water chemistry.

The flocs generated by coagulation are generally small and compact. They can also be broken down under high velocity or high shear conditions.

(iii) Flocculation

Flocculation is a process of contact and adhesion whereby the particles of a dispersion form larger-size clusters. Flocculation can occur through the use of a coagulant, flocculant, or both. Coagulants achieve flocculation through charge neutralisation where as flocculants physically bind clay and colloidal particles together.

The use of natural and synthetic polymeric flocculants can be used to generate larger more stable flocs and may reduce treatment times. This is achieved by bringing dispersed particles together increasing the effective particle size. Flocculants can be used alone, or in combination with coagulants.

(iv) Ecotoxicity

The by-products of coagulants and flocculants can, in certain circumstances, become toxic to aquatic life. A high or low water pH is often the trigger for the release of these materials in a toxic form.

It is generally accepted that dissolved aluminium at a concentration between 0.050 and 0.100 mg/L and a pH between 6.5 and 8.0 presents little threat of toxicity. However, at lower pH, the toxicity increases with an effect of possible major concern being the coagulation of mucus on the gills of fish.

There is limited published data on the aquatic ecotoxicity of calcium based coagulants such as calcium sulphate and calcium chloride.

Designers of chemical treatment systems must always seek the latest advice on the potential impacts of coagulants and flocculants on receiving waters, and must have an adequate understanding of the types of receiving water associated with any *Sediment Basin* design.

Technical Note B10 – Ecotoxicity

Ecotoxicity information has been adopted from the Auckland Regional Council TP226 and TP227 documents.

Chemical specific ecotoxicity information should be sought from chemical suppliers in accordance with the regulating authority's requirements.

(v) Jar testing

The purpose of jar testing is to select appropriate coagulants and/or flocculants along with determining their optimum dose rates. The recommended testing procedure is described below.

Jar tests are conducted on a four or six-place gang stirrer. Jars (beakers) with different treatment programs or the same product at different dosages are run side-by-side, and the results compared to an untreated beaker. Where access to a laboratory is not practicable field tests can be undertaken following a similar process to that described in the procedure with stirring and settling timeframes in multiple beakers. Testing should be undertaken by a suitably qualified person in the use of coagulants and flocculants.

Preference is given to the use of raw water collected on site which is representative of runoff (including water temperature, which affect settlement characteristics) during the life cycle of the sediment basin. Where raw water is not available representative soil from the site is to be mixed with water to create indicative runoff water chemistry. To create a water sample from soil, a recommended procedure is provided below:

Soil / water solution procedure:

- Step 1. Obtain a soil sample from representative soils to be exposed during the life cycle of the sediment basin. Where multiple soil types are likely to be encountered within the life cycle of the basin, jar tests should be undertaken for the range of soil types.
- Step 2. Crush the soil (if dry) and shake through a 2 mm sieve to remove any coarse material.
- Step 3. Place approximately 100 grams of soil into 10 litres of water. Ensure the water has the same temperature as the expected water temperature within the sediment basin during the settling phase.
- Step 4. Stir rapidly until soil particles are suspended.
- Step 5. Leave solution for 10 minutes.
- Step 6. Stir rapidly to resuspend any settled material.
- Step 7. Decant into beakers for jar testing.

Jar testing procedure:

- Step 1. Fill the appropriate number of (matched) 1000 mL transparent beakers with well-mixed test water, using a 1000 mL graduate. Adjust the water temperature to an appropriate value representative of the expected sediment basin water temperature. Record starting pH, temperature and turbidity.
- Step 2. Place the filled beakers on the gang stirrer, with the paddles positioned identically in each beaker.
- Step 3. Mix the beakers at 40–50 rpm for 30 seconds. Discontinue mixing until coagulant or flocculant addition is completed.
- Step 4. Leave the first beaker as a control, and add increasing dosages of the first coagulant/flocculant to subsequent beakers. Inject coagulant/ flocculant solutions as quickly as possible, below the liquid level and about halfway between the stirrer shaft and beaker wall.
- Step 5. Increase the mixing speed to 100–125 rpm for 15–30 seconds (rapid mix).
- Step 6. Reduce the mixing to 40 rpm and continue the slow mix for up to 5 minutes.
- Step 7. Turn the mixer off and allow settling to occur.
- Step 8. After settling for a period of time, note clarity and record on *Floc Performance Report*. Record pH and turbidity.
- Step 9. Remove the jars from the gang stirrer, empty the contents and thoroughly clean the beakers.
- Step 10. Repeat the procedure as required for different chemicals, dose rates or soil/water mixtures.

Sometimes both a coagulant and flocculant are required to achieve the desired treatment efficiencies. In these situations, the coagulant should be tested first followed by the flocculant.

For all sediment basins, including Type A, B and D, a *Floc Performance Report* should be prepared to determine a suitable chemical and dose rate for the sediment basin. A report template is provided in this section. When a variety of soil properties are likely to enter a basin during its life cycle (e.g. subsoil and topsoil), testing should be completed for all soil types. A single floc report for multiple sediment basins on a site should only be undertaken when soil properties are uniform for all basins.

Floc Performance Report

BASIN IDENTIFICATION CODE/NUMBER:

SITE / PROJECT:

PREPARED BY: **DATE:**

Chemical name:	Soil description:					
Dose rate:	0.00 Control					
Starting pH						
Starting turbidity						
Clarity^[1] after 5 mins (mm)						
Clarity^[1] after 15 mins (mm)						
Clarity^[1] after 30 mins (mm)						
Clarity^[1] after 60 mins (mm)						
Final pH						
Final turbidity						

Chemical name:	Soil description:					
Dose rate:	0.00 Control					
Starting pH						
Starting turbidity						
Clarity^[1] after 5 mins (mm)						
Clarity^[1] after 15 mins (mm)						
Clarity^[1] after 30 mins (mm)						
Clarity^[1] after 60 mins (mm)						
Final pH						
Final turbidity						

Note:

[1] For the purposes of a floc report, 'clarity' is defined as a level of turbidity that is likely to meet discharge requirements at a depth from the water level surface in the beaker. Clarity can be estimated visually or with the use of a turbidity meter.

(vi) Chemical selection for Type A and B basins

Type A and B basins require a fast acting coagulant or flocculant to perform based on the design procedure in Step 6. To ensure a suitable coagulant or flocculant is specified for the automated dosing system, the jar test assessment is critical for selection. A coagulant or flocculant should therefore only be selected if the jar test demonstrates the product will achieve a clarity of at least 100 mm within 15 minutes to allow a factor of safety. A factor of safety is required as actual settling times in the basin are likely to be longer than that in the jar testing procedure due to many factors including dosing, mixing, flow velocity and wind action.

(vii) Application of coagulants and flocculants

Mixing of coagulants and flocculants is critical to the successful treatment of turbid water. The use of passive and active treatment systems where the coagulants and/or flocculants are added to turbid water as it enters the sediment basin is recommended to speed up sediment settling rates and reduce the risk of over-dosing.

(viii) Manual batch treatment

A broad range of application techniques can be utilised for batch treatment including broad casting or spraying and single point injection with circulation. The optimum treatment method will vary depending on basin size, basin characteristics and the chemical used. Guidance from chemical suppliers or a suitably qualified sediment basin operator should be sought for appropriate application methods including safety precautions.

(ix) Passive systems

Passive systems include:

- The application of dry products such as calcium sulphate to the entire disturbed contributing catchment area.
- The application of dry products such as calcium sulphate, PAMs and biopolymers to the basin inlet drains
- The placement of PAM or PAC block products in the basin inlet basins
- The placement of biopolymer gel socks in the basin inlet drains.

While passive systems can be cost effective in some situations it is difficult to control the dosing rate. It relies on the ability of the flowing water to dissolve and mix the chemical. Passive systems require regular maintenance during flow events to replenish the used products or replace blocks/socks that have been washed into the basin. They are generally ineffective in high intensity or long duration rainfall events.

Where passive systems are the preferred application system for a Type A or B basin, the performance of the strategy will need to be significantly monitored during a wide range of storm durations and intensities to determine the appropriateness of the approach. Where monitoring indicates the strategy is not performing to the required standard, adopting an active system should be undertaken.

(x) Active systems

Active systems involve either rain or flow activated liquid dosing systems that inject the chemical(s) into the turbid water flowing into a sediment basin. Such systems maximise mixing and minimise chemical usage compared with batch or passive dosing.

Flow activated systems in their simplest form apply a static dose rate determined from jar testing however the more sophisticated units utilise real time turbidity, as well as pH,

EC and flow monitoring to adjust the dose rate as flow and water quality conditions change.

Flow activated systems are preferred to rain activated systems as chemicals are dosed into the inflow as soon as it occurs with no assumptions around rainfall losses. Flow activated systems also have the benefit of being able to accurately dose pumped water entering basins from other holding zones after a rainfall event has occurred. The systems typically require little maintenance as large chemical holding tanks can be utilised.

Rainfall activated systems generally come in two forms:

- Displacement systems
- Electronic systems

Displacement systems utilise a catchment tray sized on the contributing catchment. A displacement tank utilises captured rainfall from the catchment tray to displace and inject the chemical through a hose. The systems have been widely used and accepted in New Zealand and can be constructed by the basin operator or purchased from proprietary suppliers. A typical detail of the commonly used rainfall activated displacement system can be found in Auckland regional Council's *Guideline Document 05 – Erosion and Sediment Control Guide for Land Disturbing Activities in the Auckland Region* available online to the public. The system requires the holding tank to be emptied of rainwater and the chemical to be replaced frequently depending on the capacity of the system.

Electronic systems typically utilise a tipping bucket rain gauge to control a dose pump connected to a chemical supply. The system typically requires little maintenance as large chemical holding tanks can be utilised.

Dosing systems will need to be maintained and operated in accordance with the supplier's specifications. Dosing systems should be capable of housing and/or deploying chemical for runoff volumes up to the 5 year 24 hour storm event (e.g. 171 mm in Brisbane, 169 mm in Sydney).

B4 Default construction specifications:

Appropriate construction, operation and maintenance of sediment basins is a critical component of construction site management and environmental protection. A default specification for the construction of Sediment Basins is provided below.

Attached to the end of this section is an example 'Certification of Basin Construction' form. This, or an equivalent form, should be submitted to the relevant regulatory authority for each sediment basin constructed. Regulatory authorities are encouraged to require the submission of such forms, as well as As-constructed Plans, as mandatory for all sediment basins.

Materials

- Earth fill: clean soil with Emerson Class 2(1), 3, 4, or 5, and free of roots, woody vegetation, rocks and other unsuitable material. Soil with Emerson Class 4 and 5 may not be suitable depending on particle size distribution and degree of dispersion. Class 2(1) should only be used upon recommendation from geotechnical specialist. *[Alternatively, set a standard based on exchangeable sodium percentage – seek expert advice.]*
- Riser pipe: minimum 250 mm diameter.
- Spillway rock: hard, angular, durable, weather resistant and evenly graded rock with 50% by weight larger than the specified nominal (d_{50}) rock size. Large rock should dominate, with sufficient small rock to fill the voids between the larger rock. The diameter of the largest rock size should be no larger than 1.5 times the nominal rock size. The specific gravity should be at least 2.5.
- Geotextile fabric: heavy-duty, needle-punched, non-woven filter cloth, minimum 'bidim' A24 or equivalent.

Construction

1. Notwithstanding any description contained within the approved plans or specifications, the Contractor shall be responsible for satisfying themselves as to the nature and extent of the specified works and the physical and legal conditions under which the works will be carried out. This shall include means of access, extent of clearing, nature of material to be excavated, type and size of mechanical plant required, location and suitability of water supply for construction and testing purposes, and any other like matters affecting the construction of the works.
2. Refer to approved plans for location, dimensions, and construction details. If there are questions or problems with the location, dimensions, or method of installation, contact the engineer or responsible on-site officer for assistance.
3. Before starting any clearing or construction, ensure all the necessary materials and components are on the site to avoid delays in completing the pond once works begin.
4. Install required short-term sediment control measures downstream of the proposed earthworks to control sediment runoff during construction of the basin.
5. The area to be covered by the embankment, borrow pits and incidental works, together with an area extending beyond the limits of each for a distance not exceeding five (5) metres all around must be cleared of all trees, scrub, stumps, roots, dead timber and rubbish and disposed of in a suitable manner. Delay clearing the main pond area until the embankment is complete. *[modify as necessary to limit total area of disturbance and any damage to protected vegetation]*

6. Ensure all holes made by grubbing within the embankment footprint are filled with sound material, adequately compacted, and finished flush with the natural surface.

Cut-off trench:

7. Before construction of the cut-off trench or any ancillary works within the embankment footprint, all grass growth and topsoil must be removed from the area to be occupied by the embankment and must be deposited clear of this area and reserved for topdressing the completing the embankment.
8. Excavate a cut-off trench along the centre line of the earth fill embankment. Cut the trench to stable soil material, but in no case make it less than 600 mm deep. The cut-off trench must extend into both abutments to at least the elevation of the riser pipe crest. Make the minimum bottom width wide enough to permit operation of excavation and compaction equipment, but in no case less than 600 mm. Make the side slopes of the trench no steeper than 1:1 (H:V).
9. Ensure all water, loose soil, and rock are removed from the trench before backfilling commences. The cut-off trench must be backfilled with selected earth-fill of the type specified for the embankment, and this soil must have a moisture content and degree of compaction the same as that specified for the selected core zone.
10. Material excavated from the cut-off trench may be used in construction of the embankment provided it is suitable and it is placed in the correct zone according to its classification.

Embankment:

11. Scarify areas on which fill is to be placed before placing the fill.
12. Ensure all fill material used to form the embankment meets the specifications certified by a soil scientist or geotechnical specialist.
13. The fill material must contain sufficient moisture so it can be formed by hand into a ball without crumbling. If water can be squeezed out of the ball, it is too wet for proper compaction. Place fill material in 150 to 250 mm continuous layers over the entire length of the fill area and then compact before placement of further fill.
14. Place riser pipe outlet system, if specified, in appropriate sequence with the embankment filling. Refer to specifications supplied below.
15. Unless otherwise specified on the approved plans, compact the soil at about 1% to 2% wet of optimum and to 95% modified or 100% standard compaction.
16. Where both dispersive and non-dispersive classified earth-fill materials are available, non-dispersive earth-fill must be used in the core zone. The remaining classified earth-fill materials must only be used as directed by *[insert title]*.
17. Where specified, construct the embankment to an elevation 10% higher than the design height to allow for settling; otherwise finished dimensions of the embankment after spreading of topsoil must conform to the drawing with a tolerance of 75 mm from the specified dimensions.
18. Ensure debris and other unsuitable building waste is not placed within the earth embankment.
19. After completion of the embankment all loose uncompacted earth-fill material on the upstream and downstream batter must be removed prior to spreading of topsoil.
20. Topsoil and revegetate/stabilised all exposed earth as directed within the approved plans.

Spillway construction:

21. The spillway must be excavated as shown on the plans, and the excavated material if classified as suitable, must be used in the embankment, and if not suitable it must be disposed of into spoil heaps.
22. Ensure excavated dimensions allow adequate boxing-out such that the specified elevations, grades, chute width, and entrance and exit slopes for the emergency spillway will be achieved after placement of the rock or other scour protection measures as specified in the plans.
23. Place specified scour protection measures on the emergency spillway. Ensure the finished grade blends with the surrounding area to allow a smooth flow transition from spillway to downstream channel.
24. If a synthetic filter fabric underlay is specified, place the filter fabric directly on the prepared foundation. If more than 1 sheet of filter fabric is required, overlap the edges by at least 300 mm and place anchor pins at minimum 1 m spacing along the overlap. Bury the upstream end of the fabric a minimum 300 mm below ground and where necessary, bury the lower end of the fabric or overlap a minimum 300 mm over the next downstream section as required. Ensure the filter fabric extends at least 1000 mm upstream of the spillway crest.
25. Take care not to damage the fabric during or after placement. If damage occurs, remove the rock and repair the sheet by adding another layer of fabric with a minimum overlap of 300 mm around the damaged area. If extensive damage is suspected, remove and replace the entire sheet.
26. Where large rock is used, or machine placement is difficult, a minimum 100 mm layer of fine gravel, aggregate, or sand may be needed to protect the fabric.
27. Placement of rock should follow immediately after placement of the filter fabric. Place rock so that it forms a dense, well-graded mass of rock with a minimum of voids. The desired distribution of rock throughout the mass may be obtained by selective loading at the quarry and controlled dumping during final placement.
28. The finished slope should be free of pockets of small rock or clusters of large rocks. Hand placing may be necessary to achieve the proper distribution of rock sizes to produce a relatively smooth, uniform surface. The finished grade of the rock should blend with the surrounding area. No overfall or protrusion of rock should be apparent.
29. Ensure that the final arrangement of the spillway crest will not promote excessive flow through the rock such that the water can be retained within the settling basin at an elevation no less than 50 mm above or below the nominated spillway crest elevation.

Establishment of settling pond:

30. The area to be covered by the stored water outside the limits of the borrow pits must be cleared of all scrub and rubbish. Trees must be cut down stump high and removed from the immediate vicinity of the work.
31. Establish all required inflow chutes and inlet baffles, if specified, to enable water to discharge into the basin in a manner that will not cause soil erosion or the re-suspension of settled sediment.
32. Install a sediment storage level marker post with a cross member set just below the top of the sediment storage zone (as specified on the approved plans). Use at least a 75 mm wide post firmly set into the basin floor.
33. If specified, install internal settling pond baffles. Ensure the crest of these baffles is set level with, or just below, the elevation of the emergency spillway crest.

34. Install all appropriate measures to minimise safety risk to on-site personnel and the public caused by the presence of the settling pond. Avoid steep, smooth internal slopes. Appropriately fence the settling pond and post warning signs if unsupervised public access is likely or there is considered to be an unacceptable risk to the public.

Additional requirements for Riser Pipe Outlet Structure (Dry Basins):

1. Drill de-watering holes in the riser as specified on the plan.
2. Excavate anti-flotation pit.
3. Securely attach the riser to the conduit or conduit stub to make a watertight structural connection. Secure all connections between conduit sections by approved watertight assemblies.
4. Attach the anti-seep collars to the conduit as shown on the approved plan, or otherwise as specified.
5. Place the conduit and riser on a firm, smooth foundation of impervious soil. Do not use pervious material such as sand, gravel, or crushed rock as backfill around the conduit or anti-seep collars.
6. Place fill material around the conduit in 100 mm layers and compact around the pipe to at least the same density as the adjacent embankment. Ensure appropriate care is taken not to raise the pipe from firm contact with its foundation when compacting under the pipe haunches.
7. Place a minimum depth of 600 mm of lightly compacted backfill over the conduit before crossing it with construction equipment.
8. Anchor the riser in place by concrete or other satisfactory means to prevent flotation. Ensure the anti-flotation mass is at least 110% of water mass displaced by the riser pipe outlet system, including the volume displaced by the anti-flotation weight.
9. In no case should the conduit be installed by cutting a trench through the dam after the embankment is completed.
10. Attach anti-vortex device and trash guard to riser and as required (refer to specifications shown on the approved plan).

Certification of Sediment Basin Construction

BASIN IDENTIFICATION CODE/NUMBER:

LOCATION:

Legend: ✓ OK ✗ Not OK N/A Not applicable

Construction:

Item	Consideration	Assessment
1	Sediment basin located in accordance with approved plans.
2	Embankment material compacted in accordance with specifications.
3	Critical basin and spillway dimensions and elevations confirmed by as-constructed survey.
4	Required freeboard adjacent embankments and spillway confirmed by as-constructed survey.
5	Placement of rock on chute and upstream face of spillway in accordance with design details and standards.
6	Placement of rock within energy dissipation zone downstream of spillway in accordance with design details and standard.
7	All other sediment basin requirements in accordance with design details and standards.
8	As-constructed plan prepared for basin and spillway.

INSPECTION OFFICER **DATE**

SIGNATURE

Geotechnical:

Item	Consideration	Assessment
9	Suitable material used to form all embankments.
10	Appropriate compaction achieved in embankment construction (if observed).
11	No foreseeable concerns regarding stability or construction of the basin and spillway.

INSPECTION OFFICER **DATE**

SIGNATURE

B5 Basin maintenance

Maintenance of sediment basin

1. Inspect the sediment basin during the following periods:
 - (i) During construction to determine whether machinery, falling trees, or construction activity has damaged any components of the sediment basin. If damage has occurred, repair it.
 - (ii) After each runoff event. Inspect the erosion damage at flow entry and exit points. If damage has occurred, make the necessary repairs.
 - (iii) At least weekly during the nominated wet season (if any) otherwise at least fortnightly.
 - (iv) Prior to, and immediately after, periods of 'stop work' or site 'shutdown'.
2. Clean out accumulated sediment when it reaches the marker board/post, and restore the original storage volume. Place sediment in a disposal area or, if appropriate, mix with dry soil on the site.
3. Do not dispose of sediment in a manner that will create an erosion or pollution hazard.
4. Check all visible pipe connections for leaks, and repair as necessary.
5. Check fill material in the dam for excessive settlement, slumping of the slopes or piping between the conduit and the embankment; make all necessary repairs.
6. Remove all trash and other debris from the basin and riser.
7. Submerged inflow pipes must be inspected and de-silted (as required) after each inflow event.

Removal of sediment basin

1. When grading and construction in the drainage area above a temporary sediment basin is completed and the disturbed areas are adequately stabilised, the basin must be removed or otherwise incorporated into the permanent stormwater drainage system. In either case, sediment should be cleared and properly disposed of and the basin area stabilised.
2. Before starting any maintenance work on the basin or spillway, install all necessary short-term sediment control measures downstream of the sediment basin.
3. All water and sediment must be removed from the basin prior to the dam's removal. Dispose of sediment and water in a manner that will not create an erosion or pollution hazard.
4. Bring the disturbed area to a proper grade, then smooth, compact, and stabilise and/or revegetate as required to establish a stable land surface.

B6 References

ANCOLD 2000a, *Guidelines on Selection of Acceptable Flood Capacity for Dams*. Australian National Committee on Large Dams Inc.

ANCOLD 2000b, *Guidelines on Assessment of the Consequences of Dam Failure*. Australian National Committee on Large Dams Inc.

Auckland Regional Council 2004, *Overview of the Effects of Residual Flocculants on Aquatic Receiving Environments Technical Paper 226*, Auckland Regional Council, viewed June 2016, <<http://www.arc.govt.nz/>>.

Auckland Regional Council 2004, *Technical Publication No. 227: The Use of Flocculants and Coagulants to Aid the Settlement of Suspended Sediment in Earthworks Runoff Trials, Methodology and Design*, Auckland Regional Council, viewed June 2016, <<http://www.arc.govt.nz/>>.

Auckland Regional Council 2008, *Chemical treatment guideline*, Auckland Regional Council, viewed September 2008, <<http://www.arc.govt.nz/>>.

Brisbane City Council 2001, *Sediment Basin Design, Construction and Maintenance Guidelines*. Brisbane City Council, Brisbane.

Department of the Army 1984, *Shore Protection Manual*. Coastal Engineering Research Center, Department of the Army, US Army Corp of Engineers, Washington, DC, USA.

Englehardt, T.L. 2014, *Coagulation, Flocculation and Clarification of Drinking Water*, Hach Company, Colorado, USA.

Fifield, J.S. 2001, *Designing for Effective Sediment and Erosion Control on Construction Sites*. Forester Communications, California. ISBN 0-9707687-0-2.

Freeman, G. and Howells, L. 1995, *Saline Flocculation in Stormwater Quality Management*. Proceedings of 3rd Annual Conference on Soil and Water Management for urban Development, 12-15 September 1995. International Erosion Control Association of Australasia, Sydney.

Landcom 2004, *Managing Urban Stormwater: Soils and Construction - Volume-1*. Landcom, New South Wales Government, ISBN 0-9752030-3-7.

Ritchie, J.A. 1963, *Earthwork Tunnelling and the Application of Soil Testing Procedures*. Journal of the Soil Conservation Service of NSW, 19: 111-129.

USDA 1975, *Standards and Specifications for Soil Erosion and Sediment Control in Developing Areas*. United States Department of Agriculture, Soil Conservation Service, College Park, Maryland, USA.