

Best Practice Erosion & Sediment Control

Book 2 – Appendices A - G

November 2008

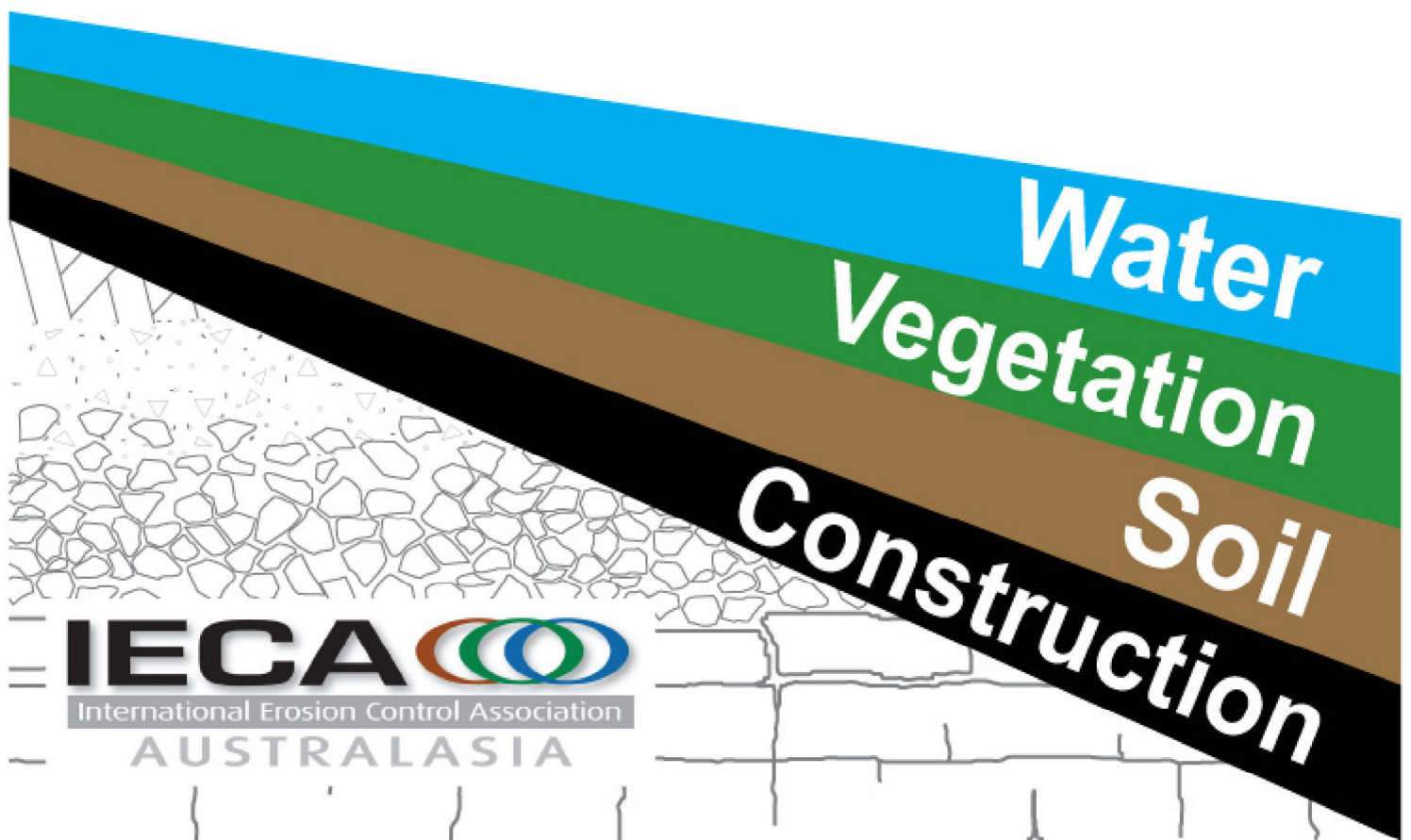

Best Practice Erosion & Sediment Control

– for building and construction sites

Book 2 – Appendices A-G

November 2008

International Erosion Control Association (Australasia)

Prepared by: Grant Witheridge, Catchments & Creeks Pty Ltd
Diagrams by: Grant Witheridge, Thomas (Jesse) Baber, and Bryde Cameron of
Catchments & Creeks Pty Ltd
Funding: Funding for the printing of this document was achieved through the
support of Natural Resource Assessment (NRA), Cairns

Published by: International Erosion Control Association (Australasian Chapter)
November 2008

1st Print: November 2008 (300 copies, coded 1000 to 1299)

1st Reprint: August 2009 (500 copies, coded 1300 to 1799)

2nd Reprint: June 2012 (500 copies, coded 1800 to 2299)

© International Erosion Control Association (Australasian Chapter), 2008

Except as permitted under various copyright laws,
no part of this publication may be reproduced or
distributed in any part form or by any means, or
stored in a database retrieval system without the
prior written permission of the publisher.

All diagrams and photos are supplied courtesy of
Catchments & Creeks Pty Ltd and remain the
ownership of Catchments & Creeks Pty Ltd. No
diagram may be reproduced or distributed in any
form or by any means, or stored in a database
retrieval system without the prior written
permission of the Director of Catchments & Creeks
Pty Ltd.

ISBN: 978-0-9806146-0-2

This document should be referenced as:

IECA 2008, *Best Practice Erosion and Sediment Control*. International Erosion Control
Association (Australasia), Picton NSW.

Key-words: ESC, erosion and sediment control plans, soil erosion, erosion control, sediment
control, soil management, land management, construction practices, building sites.

The following organisations, including the *Society for Sustainability and Environmental Engineering*, a technical society of *The Institution of Engineers Australia* (trading as *Engineers Australia*), support the continued development and application of best practice erosion and sediment control measures on building and construction sites. The “*Best Practice Erosion and Sediment Control*” document has been developed by the author for general information only and does not constitute professional advice. These organisations do not warrant the accuracy, content, completeness or suitability of the information for any purpose and will not be liable for any claims or damages resulting from reliance on the actual methodologies and/or recommendations contained within the document.



Stormwater
INDUSTRY ASSOCIATION (QLD) INC.



ENVIRONMENT
INSTITUTE OF
AUSTRALIA AND
NEW ZEALAND



**ENGINEERS
AUSTRALIA**

DISCLAIMER

Significant effort has been taken to ensure that this document is representative of current (2008) best practice erosion and sediment control; however, the authors and the International Erosion Control Association, Australasia (IECA) cannot and do not claim that the document is without error, or that the recommendations presented within this document will not be subject to future amendment. When using this document, users should ensure that they are aware of the latest (i.e. post-2008) requirements of best practice erosion and sediment control.

Use of this document, including all books and electronic media, requires professional interpretation and judgement. Appropriate investigation, planning, and design procedures must be applied in a manner appropriate for the given work activity and site conditions.

No warranty or guarantee, express, implied, or statutory is made as to the accuracy, reliability, suitability, or results of the methods or recommendations.

The authors and IECA shall have no liability or responsibility to the user or any other person or entity with respect to any liability, loss, or damage caused, or alleged to be caused, directly or indirectly, by the adoption and use of the methods and recommendations of any part of the document, including, but not limited to, any interruption of service, loss of business or anticipatory profits, or consequential damages resulting from the use of the document.

Specifically, the adoption of these best practice procedures will not guarantee:

- (i) compliance with any statutory obligations;
- (ii) compliance with specific water quality objectives;
- (iii) avoidance of environmental harm or nuisance.

Appendix A

Construction site hydrology and hydraulics

This appendix is provided as a guideline only and is not intended to replace recognised analysis and design procedures presented within hydrology/hydraulic manuals such as Australian Rainfall and Runoff (ARR). The information should only be used for the analysis and design of temporary ESC treatment measures. The procedures are not necessarily appropriate for the design of permanent drainage, erosion and sediment control systems.

This appendix greatly understates the actual complexity of catchment hydrology and the hydraulics of many drainage structures. Specifically this appendix does not provide sufficient information to allow inexperienced personnel to adequately determine design values of catchment discharge, flow velocity, and other surface flow characteristics for high-risk installations, or for the design of permanent structures.

Consultation with experienced hydraulic/hydrologic specialists and the relevant regulatory authority is always strongly recommended, unless unwarranted by the relatively small size, cost, and impact of the project or specific installation.

A1 Introduction to catchment hydrology

The design of temporary drainage and sediment control measures is generally related to either the “design discharge”, typically used in the design of drainage systems, or the “design volume” as required in the design of certain types of *Sediment Basins*.

The required design discharge (Q) or design volume (V) will depend of the specified storm frequency or Average Recurrence Interval (ARI) of the structure being designed. The nominated storm frequency may be different for different components of the same structure, for example, a *Sediment Basin* may be sized using the 1 in 1 year design storm, while the associated emergency spillway may be sized for the 1 in 10 year peak discharge.

The hydrologic methods used to determine the design discharge vary significantly from simple empirical formulas such as the Rational Method, to complex numerical models such as RORB, RAFTS, DRAINS, WBNM and URBS. The required complexity of the hydrologic method will vary with the complexity of the drainage catchment, the importance of the structure and the consequences of hydraulic failure.

The level of complexity of the hydrologic method, however, does not necessarily increase its *accuracy*, except when such methods are applied by suitably trained and experienced operators. In the hands of an inexperienced operator, a complex numerical model can potentially have a greater error range than a simple empirical formula such as the Rational Method.

Use of the Rational Method to determine peak discharges for the design of *temporary* construction-phase, hydraulic structures is generally considered satisfactory. The exception may be the design of an emergency spillway for a *Sediment Basin* where

failure of the basin would represent a significant risk to life. In urban areas the hydraulics and hydrology of emergency spillways should always be reviewed by an experienced hydraulic engineer.

Each state of Australia has recognised procedures for determining the design discharge for permanent structures. Such procedures should be adopted as recommended by the various government agencies.

A2 The Rational Method

The Rational Method is an empirical equation that uses the key hydrologic parameters of catchment area (A) and rainfall intensity (I) to estimate the peak discharge from a given catchment for a given storm frequency. The Rational Method is normally presented in the following format:

$$Q = C I A / 360 \quad (A1)$$

Where:

Q = peak discharge [m³/s] for a specified average recurrence interval (ARI) of (Y) years

C = “coefficient of discharge” for the specified average recurrence interval and catchment surface conditions (i.e. percentage urbanisation, vegetation cover, and/or degree of soil permeability)

I = average rainfall intensity [mm/hr] for a given average recurrence interval and critical storm duration (known as the “time of concentration”, t_c).

A = effective catchment area [ha] upstream of the point of interest.

For each location in a construction site where a discharge (Q) is to be determined, a new time of concentration (t_c), coefficient of discharge (C), rainfall intensity (I), and catchment area (A) will need to be determined.

The coefficient (C) is commonly referred to as either the “runoff coefficient” or the “coefficient of discharge”. This coefficient is simply a calibration term. It must **not** be confused with the “*volumetric runoff coefficient*” (refer to Section A3) which is a ratio of the total “volume of surface runoff” divided by the “volume of rainfall”.

Like any calibrated equation, a specified *coefficient of discharge* is only appropriate when used on catchments that have similar characteristics to those catchments studied during calibration of the coefficient. As such, the Rational Method is only considered suitable for use on small catchments, say less than 500 ha, that have a typical shape (i.e. not highly irregular in length or width) with gradually varying slope and infiltration characteristics.

The Rational Method has the following attributes:

- Commonly used for the design of minor drainage structures.
- Calculates peak discharge only.
- Does not provide a reliable basis for calculating runoff volume or the hydrograph shape.
- Does not make allowance for the flow attenuating effects of storage basins such as dams or *Sediment Basins*; therefore, if it is used to determine the design discharge for a *Sediment Basin* spillway, it must be assumed that the basin is full at the start of the storm.

Rational Method Procedure:

The design peak discharge for a given catchment area, average recurrence interval, and storm duration may be determined by following these steps.

- Step 1** Select the average recurrence interval (ARI) for the design storm.
- Step 2** Determine the effective catchment area (A).
- Step 3** Determine the coefficient of discharge (C).
- Step 4** Calculate the time of concentration (t_c).
- Step 5** Check for partial area effects.
- Step 6** Determine the average rainfall intensity for the nominated design storm (I).
- Step 7** Calculate the peak design discharge (Q).

Summary:

- Step 1 Either select a default design storm average recurrence interval (Y) from either Tables A1 or A2, or determine a design storm ARI based on the required probability of failure using Table A3.
- Step 2 Measure the catchment area (A) from a contour plan. Ensure all reasonable measures are taken to:
 - divert run-on water from up-slope properties around any sediment trap being designed; and
 - divert “clean” water from the construction site around any sediment trap.
- Step 3
 - Subdivide the catchment area into sub-areas of uniform soil permeability and/or vegetation cover.
 - Measure the area (ha) of each sub-area.
 - Determine an appropriate C_{10} value for each sub-area using Tables A4 and A5.
 - Determine a composite C_{10} value using Equation A3.
 - Select a Frequency Factor (F_v) from Table A7 based on the specified storm ARI (Y).
 - Determine the coefficient of discharge (C) using Equation A4.
- Step 4
 - Subdivide the longest flow path into segments of uniform flow condition.
 - Determine the flow travel time for each segment using the procedures outlined in Step 4 (a), (b), (c), (d) and (e).
 - Sum the individual segment flow times to determine the “time of concentration” (t_c).
- Step 5 If the drainage catchment has an unusual shape, either in length or width, then seek expert advice regarding possible *Partial Area Effects*.
- Step 6 Select the average rainfall intensity (I) from the local IFD chart.
- Step 7 Determine the design discharge (Q) using the Rational Method equation.

$$Q = C.I.A/360$$

Step 1 Select the average recurrence interval (ARI) for the design storm.

The recommended average recurrence interval for various ESC treatment measures is outlined in Tables A1 and A2.

Table A1 – Drainage design standard for temporary drainage works

| Drainage structure | Anticipated design life | | |
|---|---|--------------|--------------|
| | < 12 months | 12–24 months | > 24 months |
| Temporary drainage structures ^[1] Queensland, Northern Territory, and northern Western Australia | 1 in 2 year | 1 in 5 year | 1 in 10 year |
| Temporary drainage structures ^[1] New South Wales, Victoria, Tasmania, South Australia and southern Western Australia | 1 in 5 year | 1 in 10 year | 1 in 10 year |
| Temporary drainage structures (e.g. Catch Drain, Flow Diversion Bank) located immediately up-slope of an occupied property that would be adversely affected by the failure or overtopping of the structure. ^{[1], [2]} | 1 in 10 year | 1 in 10 year | 1 in 10 year |
| Temporary culvert crossing | Minimum 1 in 1 year hydraulic capacity wherever reasonable and practicable. | | |

Notes: [1] Design capacity excludes minimum 150 mm freeboard.

[2] Design flow rate based on up-slope drainage structures operating in accordance with their design capacity excluding freeboard, i.e. any constructed freeboard is assumed to have been washed away or otherwise deactivated.

Table A2 – Recommended design standard for emergency spillways on temporary *Sediment Basins* ^[1]

| Design life | Minimum design storm ARI |
|--|------------------------------|
| Less than 3 months operation | 1 in 10 year |
| 3 to 12 months operation | 1 in 20 year |
| Greater than 12 months | 1 in 50 year |
| If failure is expected to result in loss of life | Probable Maximum Flood (PMF) |

Note: [1] Alternative design requirements may apply to Referable Dams in accordance with State legislation, or as recommended by the Australian National Committee on Large Dams Inc. (ANCOLD 2000a & 2000b).

In situations where it is required to determine a site-specific design storm frequency based on a given probability of exceedance, then Equation A2 can be used.

$$P = 100.(1 - \text{Exp}(-L/Y)) \quad (\text{A2})$$

where:

P = Probability [%] of one or more storms of an average recurrence interval of "Y" years occurring during the design life (L) of the structure

L = Design life of the structure (must be ≥ 1 yr) [years]

Y = Average recurrence interval (ARI) of the specified storm event [years]

The probability of exceedance of a given storm ARI during a specified design life is presented in Table A3. For further discussion refer to Section 1.8, Book 3, ARR-1998.

Table A3 – Probability (%) of one or more exceedances during the design life

| Design Life (years) | Average recurrence interval (ARI) of specified storm | | | | | | |
|---------------------|--|-----|-----|------|------|------|-------|
| | 1yr | 2yr | 5yr | 10yr | 20yr | 50yr | 100yr |
| 1 | 63 | 39 | 18 | 10 | 5 | 2 | 1 |
| 2 | 86 | 63 | 33 | 18 | 10 | 4 | 2 |
| 3 | 95 | 78 | 45 | 26 | 14 | 6 | 3 |
| 4 | 98 | 86 | 55 | 33 | 18 | 8 | 4 |
| 5 | 99 | 92 | 63 | 39 | 22 | 10 | 5 |
| 10 | 100 | 99 | 86 | 63 | 39 | 18 | 10 |
| 20 | 100 | 100 | 98 | 86 | 63 | 33 | 18 |
| 30 | 100 | 100 | 100 | 95 | 78 | 45 | 26 |
| 40 | 100 | 100 | 100 | 98 | 86 | 55 | 33 |
| 50 | 100 | 100 | 100 | 99 | 92 | 63 | 39 |

Step 2 Determine the effective catchment area (A).

One of the primary goals of an effective erosion and sediment control program is to divert external run-on water and any uncontaminated site water around major sediment traps such as a *Sediment Basin*. This can reduce the size and cost of the various downstream sediment traps as demonstrated in Figure A1.

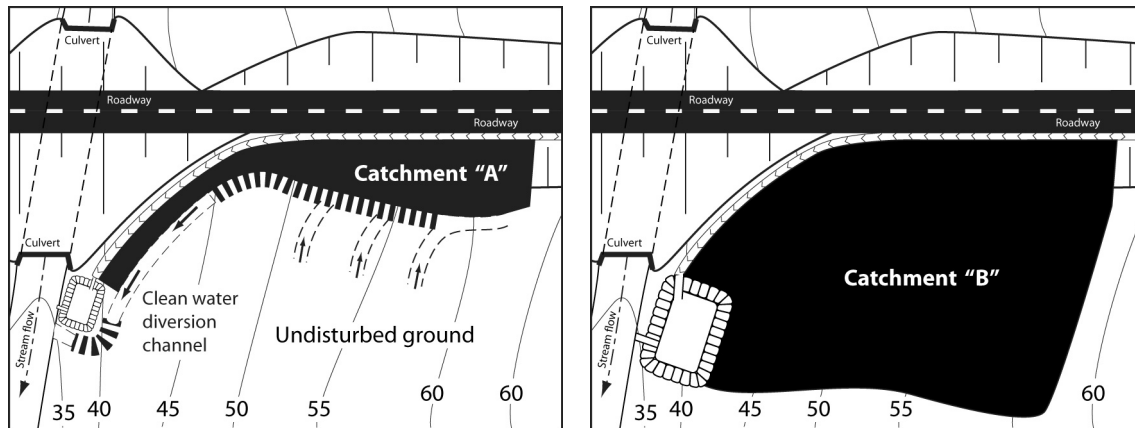

(a) Up-slope “clean” water diverted around the *Sediment Basin*

(b) Up-slope “clean” water not diverted around the *Sediment Basin*

Figure A1 – Beneficial effects of diverting “clean” water around a basin

The effective catchment area must be determined separately for each hydraulic structure being designed.

When determining the catchment area, the following points should be considered:

- The effective catchment area may vary significantly during the construction phase as areas of disturbance are first connected to a *Sediment Basin*, then taken off-line as site rehabilitation occurs. The preparation of a Construction Drainage Plan (CDP) for each stage of construction will greatly assist in defining changes in catchment area.
- It is very important to mark all temporary and permanent roads and tracks on the Construction Drainage Plans because stormwater runoff will usually be diverted along these roads.
- In some cases, *Sediment Fences* can also divert flow into or away from a given sub-catchment.

Step 3 Determine the coefficient of discharge (C).

The coefficient of discharge (C) varies in accordance with the nominated average recurrence interval (ARI) of the design storm and the storm duration. The values of (C) presented in Table A4 are those associated with a 1 in 10 year ARI as recommended for use in Queensland. Such values are normally referred to as “C₁₀” values.

Note: Designers should contact their local government or relevant State government office for coefficients of discharge appropriate for their region.

Table A4 – Coefficient of discharge (C₁₀) for 1 in 10 year average recurrence interval (source: QUDM, 2007)

| Intensity (mm/hr) ¹ I ₁₀ | Fraction impervious | | | | | | |
|---|---------------------|------|------|------|------|------|------|
| | 0.00 | 0.20 | 0.40 | 0.60 | 0.80 | 0.90 | 1.00 |
| 39–44 | Refer to Table A5 | 0.44 | 0.55 | 0.67 | 0.78 | 0.84 | 0.90 |
| 45–49 | | 0.49 | 0.60 | 0.70 | 0.80 | 0.85 | 0.90 |
| 50–54 | | 0.55 | 0.64 | 0.72 | 0.81 | 0.86 | 0.90 |
| 55–59 | | 0.60 | 0.68 | 0.75 | 0.83 | 0.86 | 0.90 |
| 60–64 | | 0.65 | 0.72 | 0.78 | 0.84 | 0.87 | 0.90 |
| 65–69 | | 0.71 | 0.76 | 0.80 | 0.85 | 0.88 | 0.90 |
| 70–90 | | 0.74 | 0.78 | 0.82 | 0.86 | 0.88 | 0.90 |

¹I₁₀ = One hour average rainfall intensity for a 1 in 10 year ARI

C₁₀ = Coefficient of discharge for a 1 in 10 year ARI

Table A5 – C₁₀ values for zero fraction impervious [1]

| Land description: | Dense bushland | | | Medium density bush, or Good grass cover, or High density pasture, or Zero tillage cropping | | | Light cover bushland, or Poor grass cover, or Low density pasture, or Open construction site | | |
|---|-----------------------|------|------|---|------|------|--|------|---------|
| | Soil permeability [2] | | | Soil permeability [2] | | | Soil permeability [2] | | |
| Intensity (mm/hr) ¹ I ₁₀ | High | Med | Low | High | Med | Low | High | Med | Low [3] |
| 39–44 | 0.08 | 0.24 | 0.32 | 0.16 | 0.32 | 0.40 | 0.24 | 0.40 | 0.48 |
| 45–49 | 0.10 | 0.29 | 0.39 | 0.20 | 0.39 | 0.49 | 0.29 | 0.49 | 0.59 |
| 50–54 | 0.12 | 0.35 | 0.46 | 0.23 | 0.46 | 0.58 | 0.35 | 0.58 | 0.69 |
| 55–59 | 0.13 | 0.40 | 0.53 | 0.27 | 0.53 | 0.66 | 0.40 | 0.66 | 0.70 |
| 60–64 | 0.15 | 0.44 | 0.59 | 0.30 | 0.59 | 0.70 | 0.44 | 0.70 | 0.70 |
| 65–69 | 0.17 | 0.50 | 0.66 | 0.33 | 0.66 | 0.70 | 0.50 | 0.70 | 0.70 |
| 70–90 | 0.18 | 0.53 | 0.70 | 0.35 | 0.70 | 0.70 | 0.53 | 0.70 | 0.70 |

Note: [1] Developed from Queensland Department of Natural Resources and Mines (2005). Extreme caution should be exercised when applying these coefficients to soils compacted by construction activities.

[2] High permeability is well-drained sandy soils; Medium permeability is sandy loam, loam and clayey loam soils; Low permeability is clayey soils and dispersive soils.

[3] A low soil permeability should normally be assumed on loamy or clayey-soil construction sites subject to heavy earthmoving and construction traffic.

If the drainage catchment includes some established urbanised areas, then an estimation of the fraction impervious may be obtained from Table A6.

Table A6 – Fraction impervious vs. development category

| Development category | Fraction impervious |
|---|---------------------|
| Central Business | 1.00 |
| Commercial, Local Business, General Industry | 0.90 |
| Significant Paved Areas e.g. roads and car parks | 0.90 |
| Urban Residential – High Density | 0.70 to 0.90 |
| Urban Residential – Low Density (including roads) | 0.45 to 0.85 |
| Urban Residential – Low Density (excluding roads) | 0.40 to 0.75 |
| Rural Residential | 0.10 to 0.20 |
| Open Space & Parks etc. | 0.00 |

(i) Composite values of the coefficient of discharge:

On most construction sites the vegetative cover of the soil surface will vary significantly throughout the duration of the construction and rehabilitation phases. In addition, some soil surfaces will be subjected to compaction by earthmoving equipment and/or construction traffic, thus reducing the soil's permeability. To account for variations in soil permeability (or fraction impervious) across a drainage catchment, a composite value of the coefficient of discharge must be determined using Equation A3.

$$C_{10} = \frac{\sum(C_{10,i} \cdot A_i)}{\sum(A_i)} \quad (\text{A3})$$

(ii) Frequency factor:

In order to determine the coefficient of discharge for a design storm with an average recurrence interval **other than** 1 in 10 years, it is necessary to multiply the coefficient of discharge by the *Frequency Factor* (F_Y) using Equation A4. Frequency factors for a range of average recurrence intervals are presented in Table A7.

$$C_Y = F_Y \cdot C_{10} \leq 1.0 \quad (\text{A4})$$

where:

- C_Y = Coefficient of discharge for an average recurrence interval of Y years
- F_Y = Frequency factor for an average recurrence interval of Y years
- C_{10} = Coefficient of discharge for an average recurrence interval of 10 years

Table A7 – Frequency factor

| ARI (years) | Frequency Factor (F_Y) | Note: |
|-------------|----------------------------|--|
| 1 | 0.80 | Where a coefficient of discharge calculated from Equation A4 for an urban catchment exceeds 1.0, it should be arbitrarily set to 1.0 in accordance with the recommendations of Australian Rainfall and Runoff (ARR, 1998). |
| 2 | 0.85 | |
| 5 | 0.95 | |
| 10 | 1.00 | |
| 20 | 1.05 | |
| 50 | 1.15 | |
| 100 | 1.20 | |

Step 4 Determine the time of concentration (t_c).

The time of concentration for a drainage catchment is defined as “the time required for stormwater runoff to flow from the most remote part of the catchment to the location where the discharge is to be determined”. The following procedures are appropriate to Queensland, but may not be appropriate to other regions of Australia.

It is, however, noted that the maximum travel time may not necessarily occur along the travel path of maximum length, and may not necessarily extend to the highest elevation within the catchment.

The time of concentration is important because it determines the shortest storm duration that will enable runoff from all parts of the catchment to contribute to the discharge at the point of interest at the time of maximum discharge. Also, the smaller the storm duration, the larger the average rainfall intensity for a given storm frequency as demonstrated in Figure A2.

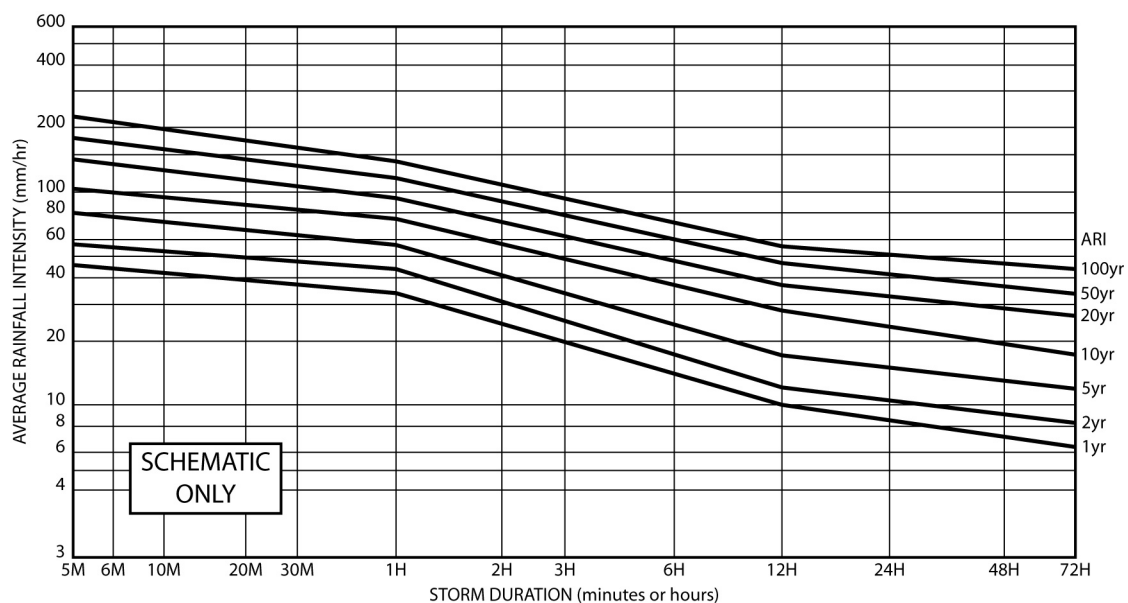

Figure A2 – Typical rainfall intensity-frequency-duration (IFD) chart

As stormwater runoff passes through a typical construction site, it initially travels as *sheet flow*, but only over a short distance, before concentrating into small channels or rills. Eventually the runoff is collected by *Catch Drains* or *Flow Diversion Banks* before being discharged into a drainage *Chute*, road reserve or watercourse.

To determine the total travel time of stormwater runoff through a catchment it will be necessary to sum the travel times of flow through various sectors represented by uniform flow condition. The various flow conditions include:

- initial sheet flow (see (a) below);
- roadside kerb or swale flow (see (b) below);
- pipe flow (see (c) below);
- minor channel flow (see (d) below);
- major channel flow (i.e. large *Flow Diversion Channel* or watercourse—see (d) or (e) below).

Determining the travel time along a watercourse is normally only required when estimating stream flows for the design of *Temporary Watercourse Crossings*. If design

of such crossings is critical, then the estimation of stream flow should be done by an experienced hydrologist using appropriate hydrologic procedures.

(a) Initial sheet flow travel time:

The travel time of the initial sheet flow depends on whether the upper part of the catchment is:

- urbanised (i.e. a well-drained urban area); or
- an area of open soil, grassland or bushland.

The procedure for determining the travel time of initial sheet flow for each of the above catchment conditions is presented as (i) and (ii) below.

(i) Top of catchment is finished urban construction.

The recommended travel time of initial sheet flow with urban areas is presented in Table A8.

Table A8 – Standard inlet time

| Description of top of catchment | Inlet Time (t) |
|---|----------------|
| Road surfaces and paved areas | 5 min. |
| Urban areas where average slope of land at top of catchment > 15% | 5 min. |
| Urban areas where average slope of land at top of catchment is 10% to 15% | 8 min. |
| Urban areas where average slope of land at top of catchment is 6% to 10% | 10 min. |
| Urban areas where average slope of land at top of catchment is 3% to 6% | 13 min. |
| Urban areas where average slope of land at top of catchment is up to 3%. | 15 min. |

(ii) Top of catchment is bare soil, grassland or bushland.

Travel time of initial overland (sheet) flow through grass or bushland is determined from the Friend's Equation (Equation A5) or Figure A3.

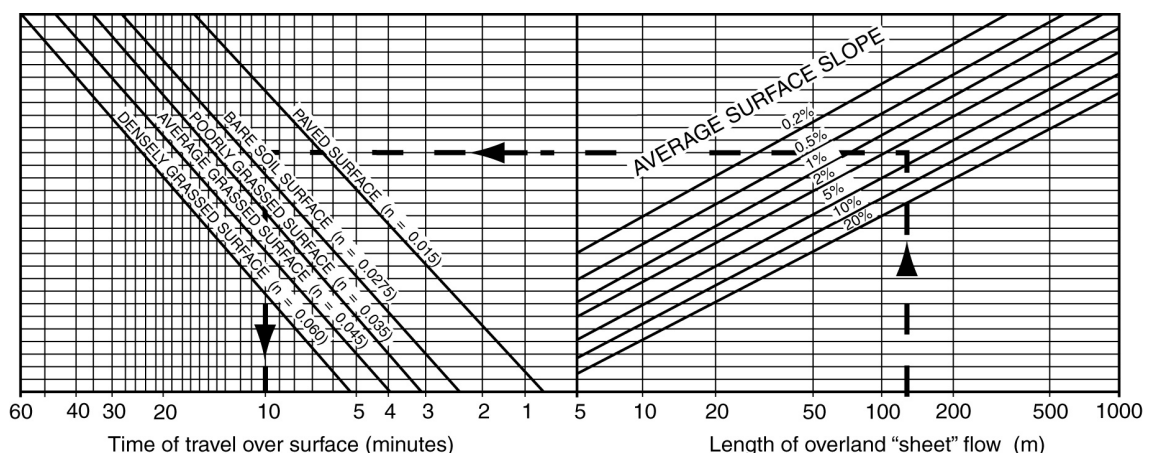

Figure A3 – Overland sheet flow times – shallow sheet flow only (sourced from ARR-1977)

$$t = (107 n L^{0.333})/S^{0.2} \quad (A5)$$

where:

t = travel time [minutes]

n = Horton's roughness value (adopt n = 0.028 for bare soil, 0.045 for grassland, 0.035 for bushland)

L = overland sheet flow path length [m]

S = slope of surface [%] = [m/km]/10

The recommended maximum travel length of sheet flow is presented in Table A9. If the actual travel distance from the top of the catchment to the nearest drain or channel is greater than the distance presented in Table A9, then an additional travel time (based on concentrated flow) must be added for this additional distance.

Table A9 – Recommended maximum length of overland sheet flow

| Surface Condition | Assumed Maximum Flow Length (m) |
|--|---------------------------------|
| Steep (say >10%) grassland (Horton's n = 0.045) | 20 |
| Steep (say >10%) bushland (Horton's n = 0.035) | 50 |
| Medium gradient (approx. 5%) bushland or grassland | 100 |
| Flat (0–1%) bushland or grassland | 200 |

(b) Kerb flow times

The travel time of flow down a roadside in kerb should be determined by dividing the length of kerb by the average velocity of the flow. An estimation of the travel time for flow within roadside kerbs may be obtained from Equation A6 (sourced from QUDM, 2007).

$$t = 0.025 L / S^{0.5} \quad [\text{minutes}] \quad (A6)$$

where:

t = time of kerb flow [minutes]

L = length of kerb flow [metres]

S = slope of kerb [%] = [m/km]/10

(c) Pipe flow travel times

Wherever practical, pipe travel times should be based on calculated pipe velocities using either a Manufacturer's Pipe Flow Chart (n = 0.013 for concrete pipes), or uniform flow calculations based on Manning's equation (refer to (d) below).

Alternatively, if the travel time within the pipe is small compared to the overall travel time of concentration, then an average pipe velocity of 2 m/s and 3 m/s may be adopted for low gradient (say flatter than 1 in 150) and medium to steep gradient pipelines respectively.

(d) Channel flow travel times

The time stormwater takes to flow along an open channel may be determined directly from the estimated average velocity of the flow. The average velocity of the flow within an open channel may be calculated using the Manning equation (Equation A7).

$$V = (1/n) R^{2/3} S^{1/2} \quad (\text{A7})$$

$$\text{From which: } t = L/(60.V) = n \cdot L / 60 (R^{2/3} \cdot S^{1/2}) \quad (\text{A8})$$

where:

V = average velocity [m/s]

n = Manning's roughness coefficient (refer to Section A5.2)

R = hydraulic radius [m] (refer to Section A5.4 & A6)

S = channel bed slope [m/m] (uniform flow conditions are assumed)

L = length of channel/pipe [m]

t = travel time [minutes]

(e) Major watercourse

In circumstances where it is necessary to estimate the time of concentration for a large drainage catchment (say, >100 ha) which contains a watercourse with well-defined bed and banks, then it is highly recommended that expert advice be sought from a suitably training hydrologist or hydraulic engineer.

In circumstances where the estimation of design flow is not critical, then the Bransby-Williams' Equation (Equations A9) can be used for rural catchments, and Stream Velocity Method (Table A10) for urban catchments. It is noted that when such methods are used, it is **not** appropriate to include any additional flow travel times such as the initial overland flow or standard inlet time.

$$\text{Bransby-Williams Equation: } t_c = 58 L / (A^{0.1} \cdot S_e^{0.2}) \quad (\text{A9})$$

where:

t_c = the time of concentration [min]

L = length [km] of flow path from catchment divide to outlet

A = catchment area [ha]

S_e = equal area slope of stream flow path [%] as defined in Figure A4 where [%] = [m/km]/10.

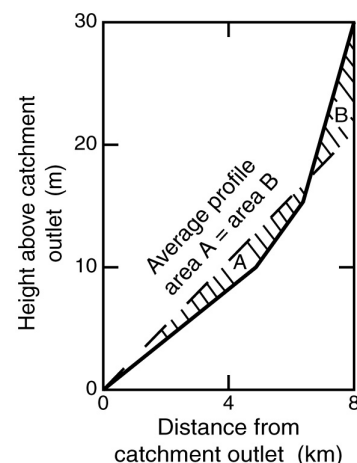

Figure A4 – Derivation of equal area slope (S_e)

Note: units of equal area slope (S_e) determined from Figure A4 need to be converted to units of [%].

Table A10 – Nominal stream velocities for the purpose of determining the *time of concentration* for use in the Rational Method^[1,2]

| Nominal Stream Velocity (m/s) ^[3] | Original USA Catchment Description | Queensland Main Roads Description |
|--|------------------------------------|-----------------------------------|
| | Type of Topography | Average Catchment Surface Slope |
| 0.3 | Flat | 0 to 1.5% |
| 0.7 | Rolling | 1.5 to 4% |
| 0.9 | Hilly | 4 to 8% |
| 1.5 | Steep | 8 to 15% |
| 3.0 | Very Steep Rocky Mountains | > 15% |

Notes: [1] Developed from the Stream Velocity Method presented in Queensland Department of Main Roads method presented in Book 4, Australian Rainfall and Runoff (1998).

[2] Only suitable for use in the design of temporary, non-critical, hydraulic structures. Not intended for use in the design of permanent systems such as stream diversions, permanent drainage systems, or permanent sediment control structures.

[3] The “nominal stream velocity” does **not** represent actual stream velocities. Instead it represents an assumed flow velocity suitable for use only in the estimation of an appropriate *time of concentration* for use within the Rational Method.

Example A1**Problem:**

Calculate the time of concentration and coefficient of discharge (C_2) for an average recurrence interval storm of 1 in 2 years.

Catchment conditions:

Catchment located in Townsville, Queensland ($I_{10} = 80.6$ mm/hr)

Total catchment area = 2 ha

Bare soil with top of catchment slope = 5%

Soil conditions: clayey loam compacted by construction traffic

Travel distance of sheet flow = 36 m

Total travel distance within catch drain = 100 m at a velocity of 0.6 m/s

Solution:

$$C_{10} = 0.7 \quad (\text{Table A5})$$

$$F_2 = 0.85 \quad (\text{Table A7})$$

$$C_2 = 0.85 \times 0.7 = 0.595 \leq 1.0 \text{ (OK)} \quad (\text{Eqn A4})$$

Time of concentration = initial sheet flow time + travel time on catch drains

$$\text{Initial sheet flow time} = (107 \times 0.028 \times 36^{0.333}) / (5)^{0.2} = 7.16 \text{ minutes} \quad (\text{Eqn A5})$$

$$\text{Travel time along catch drain} = 100 / (0.6 \times 60) = 2.78 \text{ minutes} \quad (\text{Eqn A8})$$

$$\text{Time of concentration} = 7.16 + 2.78 = 9.94 \text{ minutes, say 10 minutes}$$

Example A2**Problem:**

Calculate the time of concentration and coefficient of discharge (C_{100}) for an average recurrence interval storm of 1 in 100 years.

Catchment conditions:

Catchment location is Townsville, Queensland ($I_{10} = 80.6$ mm/hr)

Total catchment area = 9 ha

Land use: (i) urban residential area = 6 ha (top of catchment) $C_{10} = 0.78$

(ii) industrial area = 2 ha $C_{10} = 0.88$

(iii) open space = 1 ha $C_{10} = 0.70$

Top of catchment slope = 9%

Length of kerb flow = 100 m at an average 4% slope

Length of piped flow = 200 m

Stream length = 400 m

Average stream velocity = 1.5 m/s

Solution:

$$C_{10} = \Sigma((0.78 \times 6) + (0.88 \times 2) + (0.7 \times 1)) / 9 = 0.793 \quad (\text{Eqn A3})$$

$$F_{100} = 1.20 \quad (\text{Table A7})$$

$$C_{100} = 1.20 \times 0.793 = 0.952 \leq 1.0 \text{ (OK)} \quad (\text{Eqn A4})$$

Time of concentration (t_c) = standard inlet time + pipe travel time + stream travel time

$$\text{Adopt a standard inlet time} = 10 \text{ minutes (for slope = 9\%)} \quad (\text{Table A8})$$

$$\text{Kerb flow time} = (0.025 \times 100) / \sqrt{(4)} = 1.25 \text{ minutes} \quad (\text{Eqn A6})$$

Assume an average pipe flow velocity = 3.0 m/s

$$\text{Piped travel time} = 200 / (60 \times 3.0) = 1.1 \text{ minutes}$$

$$\text{Stream travel time} = 400 / (60 \times 1.5) = 4.4 \text{ min. (given the stream velocity = 1.5 m/s)}$$

$$\text{The time of concentration } (t_c) = (10 + 1.25 + 1.1 + 4.4) = 16.75 \text{ min. say 17 minutes}$$

Step 5 Check for partial area effects.

In most cases, the critical time of concentration (t_c) for a given location is the longest flow travel time to the point of interest. In some cases, however, the maximum catchment discharge may occur when a shorter duration storm of higher average intensity is applied to only part of the catchment. This is referred to as a “partial area effect”.

Partial area effects normally occur when the upstream end of the catchment area is unusually elongated, or when there is non-uniform urbanisation of the catchment. The onus is on the designer to be aware of the possibility of partial area effects and to check, as necessary, to ensure that the correct peak discharge is obtained.

Examples of partial area effects are provided in Figure A5.

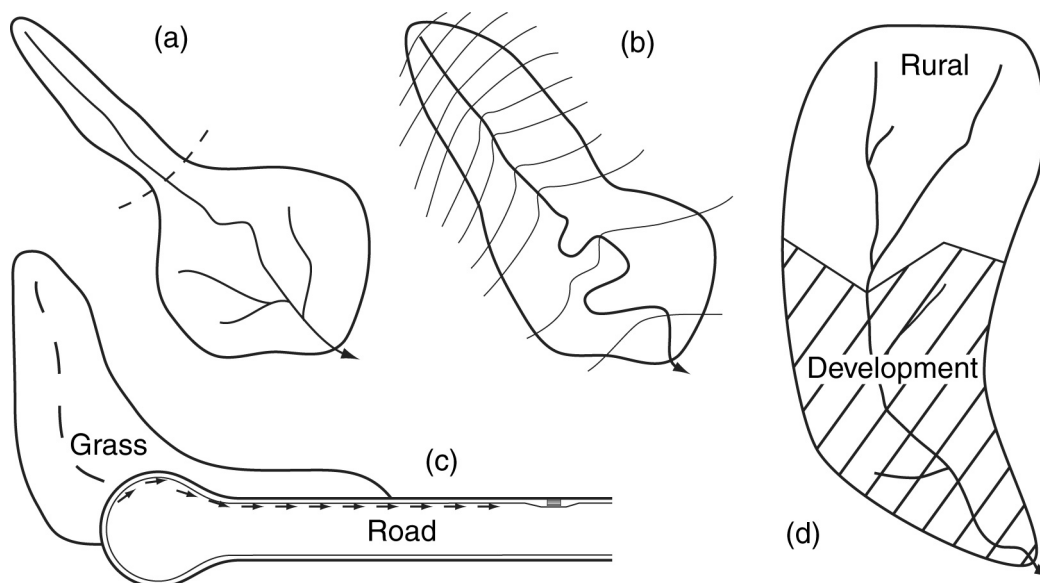

Figure A5 – Examples of catchment areas where partial area effects may exist

If partial area effects are considered likely to occur on a given catchment, then a higher peak discharge might be obtained if that part of the drainage catchment that has an unusual shape or slope is removed from the catchment area and time of concentration assessment.

Step 6 Determine the design average rainfall intensity.

The design average rainfall intensity (I) must be determined for a given storm duration (t_c) and storm frequency (Y). The rainfall intensity is usually obtained from an Intensity-Frequency-Duration (IFD) chart developed for the local region.

An example IFD chart for Townsville, Queensland is presented in Table A11.

Table A11 – Example rainfall IFD chart for Townsville, Queensland

| Time (min) | 1 Yr | 2Yr | 5Yr | 10Yr | 20Yr | 50Yr | 100Yr |
|--------------|-------------|-------------|-------------|-------------|-------------|-------------|-------------|
| 5 | 114 | 148 | 193 | 220 | 256 | 303 | 339 |
| 6 | 110 | 142 | 185 | 211 | 245 | 290 | 325 |
| 7 | 105 | 135 | 177 | 201 | 234 | 277 | 310 |
| 8 | 99.8 | 129 | 169 | 193 | 224 | 265 | 296 |
| 9 | 95.6 | 124 | 162 | 184 | 214 | 254 | 284 |
| 10 | 91.9 | 119 | 156 | 177 | 206 | 244 | 273 |
| 11 | 88.5 | 115 | 150 | 171 | 198 | 235 | 263 |
| 12 | 85.5 | 111 | 145 | 165 | 192 | 227 | 254 |
| 13 | 82.7 | 107 | 140 | 160 | 186 | 220 | 246 |
| 14 | 80.3 | 104 | 136 | 155 | 180 | 214 | 239 |
| 15 | 78.0 | 101 | 132 | 151 | 175 | 208 | 233 |
| 16 | 76.0 | 98.5 | 129 | 147 | 171 | 202 | 227 |
| 17 | 74.1 | 96.1 | 126 | 143 | 166 | 197 | 221 |
| 18 | 72.3 | 93.8 | 123 | 140 | 163 | 193 | 216 |
| 19 | 70.7 | 91.7 | 120 | 137 | 159 | 188 | 211 |
| 20 | 69.2 | 89.7 | 117 | 134 | 156 | 184 | 207 |
| 22 | 66.4 | 86.2 | 113 | 129 | 149 | 177 | 199 |
| 24 | 64.0 | 83.0 | 109 | 124 | 144 | 171 | 191 |
| 26 | 61.8 | 80.2 | 105 | 120 | 139 | 165 | 185 |
| 28 | 59.8 | 77.6 | 102 | 116 | 135 | 160 | 179 |
| 30 | 58.0 | 75.3 | 98.5 | 112 | 131 | 155 | 174 |
| 40 | 50.8 | 65.9 | 86.3 | 98.6 | 115 | 136 | 152 |
| 50 | 45.6 | 59.1 | 77.4 | 88.4 | 103 | 122 | 137 |
| 60 | 41.5 | 53.6 | 70.5 | 80.8 | 93.7 | 111 | 125 |
| 2 hr | 27.4 | 35.6 | 46.8 | 54.0 | 62.0 | 74.0 | 83.0 |
| 3 hr | 21.4 | 27.8 | 36.6 | 42.0 | 48.9 | 58.0 | 65.0 |
| 6 hr | 14.0 | 18.2 | 24.0 | 27.6 | 32.1 | 38.3 | 43.0 |
| 12 hr | 9.18 | 12.0 | 15.8 | 18.2 | 21.3 | 25.3 | 28.4 |
| 24 hr | 6.10 | 8.01 | 10.8 | 12.5 | 14.8 | 17.8 | 20.1 |
| 48 hr | 3.96 | 5.24 | 7.22 | 8.46 | 10.1 | 12.2 | 14.0 |
| 72 hr | 3.00 | 3.98 | 5.56 | 6.57 | 7.86 | 9.62 | 11.0 |

Step 7 Calculate the design peak discharge.

When all the necessary parameters have been determined, the design peak discharge is calculated using the Rational Method formula.

$$Q = C I A/360 \quad (A10)$$

Example A3

Problem:

Calculate the 1 in 1 year design ARI peak discharge (Q1) for the following conditions.

Catchment conditions:

Catchment is located in Townsville, Queensland (${}^1I_{10} = 80.8$ mm/hr)

Total catchment area = 2 ha

Land use:

- 1.2 ha bare soil with medium soil permeability
- 0.8 ha grassland at top of catchment with 5% slope

Drainage path:

- 50 m top of catchment to first catch drain
- 100 m long catch drain with a design flow velocity of 0.5 m/s
- 50 m grass chute with a design flow velocity of 2 m/s

Solution:

$$C_{10} = ((0.7 \times 1.2) + (0.7 \times 0.8))/2 = 0.7 \quad (\text{Eqn A3})$$

$$C_1 = F_1 \times C_{10} = 0.80 \times 0.7 = 0.56 \quad (\text{Eqn A4})$$

Calculate time of concentration (t_c):

$$\text{Initial sheet flow time: } t = (107 \times 0.045 \times 50^{0.333})/5^{0.2} = 12.8 \text{ minutes} \quad (\text{Eqn A5})$$

$$\text{Catch drain travel time: } t = 100/(60 \times 0.5) = 3.3 \text{ minutes} \quad (\text{Eqn A8})$$

$$\text{Grass chute travel time: } t = 50/(60 \times 2.0) = 0.4 \text{ minutes} \quad (\text{Eqn A8})$$

$$\text{Total travel time: } t_c = 12.8 + 3.3 + 0.4 = 16.5 \text{ min., say } 17 \text{ minutes}$$

Determine average rainfall intensity (${}^{17}I_1$):

$${}^{17}I_1 = 74.1 \text{ mm/hr} \quad (\text{Table A11})$$

Calculate the 1 in 1 year ARI (Q1) peak discharge:

$$Q1 = C.I.A/360 = (0.56 \times 74.1 \times 2.0)/360 = 0.23 \text{ m}^3/\text{s} \quad (\text{Eqn A1})$$

A3 Estimation of runoff volume

An estimation of runoff volume may be required for the sizing of Type F and Type D *Sediment Basins*.

The *volumetric runoff coefficient* (C_v) is defined as the ratio of the volume of stormwater runoff to the volume of rainfall that produced the runoff as presented in Equation A11.

$$V = (C_v \cdot R \cdot A)/1000 \quad (\text{A11})$$

where:

- V = runoff volume for the nominated storm event [m^3]
- C_v = volumetric runoff coefficient
- R = total rainfall [mm]
- A = catchment area [m^2]

It should be noted that:

- The volumetric runoff coefficient (C_v) is **not** the same as the Rational Method coefficient of discharge (C).
- The volumetric runoff coefficient for a “single storm event” will almost certainly be different from the “average annual volumetric runoff coefficient”—the latter being a ratio of average annual runoff to average annual rainfall.

Given point (ii) above, if a reference is made to an assessed volumetric runoff coefficient, or a coefficient is determined from a design guideline, then it is important to acknowledge whether the coefficient refers to a single storm event, or to annual average conditions.

A3.1 Estimation of runoff volume from a single storm

An estimation of runoff volume from a single storm event may be obtained using one of the following methods:

- a volume calibrated runoff–routing model;
- use of the single storm event volumetric runoff coefficient (Table A12);
- direct extraction of estimated rainfall losses from a given rainfall hyetograph.

The actual runoff volume will be dependent on a number of variables including soil type, depth of soil, land slope, type and density of vegetation cover, and the degree of soil moisture at the start of the storm event.

Table A12 provides typical volumetric runoff coefficients for single storm events occurring over various soil types. These volumetric runoff coefficients originated from the investigations of the US Department of Agriculture and are expected to be applicable to typical agricultural land with a soil slope of less than say 5%.

For soil slopes in excess of 10% the volumetric runoff coefficients are expected to be significantly larger than those listed in Table A12; however, it is noted that the volumetric runoff coefficient cannot exceed unity (1.0).

Table A12 – Typical single storm event volumetric runoff coefficients ^[1]

| Rainfall (mm) | Soil Hydrologic Group | | | |
|---------------|-----------------------|--------------------|--------------------|--------------|
| | Group A Sand | Group B Sandy loam | Group C Loamy clay | Group D Clay |
| 10 | 0.02 | 0.10 | 0.09 | 0.20 |
| 20 | 0.02 | 0.14 | 0.27 | 0.43 |
| 30 | 0.08 | 0.24 | 0.42 | 0.56 |
| 40 | 0.16 | 0.34 | 0.52 | 0.63 |
| 50 | 0.22 | 0.42 | 0.58 | 0.69 |
| 60 | 0.28 | 0.48 | 0.63 | 0.74 |
| 70 | 0.33 | 0.53 | 0.67 | 0.77 |
| 80 | 0.36 | 0.57 | 0.70 | 0.79 |
| 90 | 0.41 | 0.60 | 0.73 | 0.81 |
| 100 | 0.45 | 0.63 | 0.75 | 0.83 |

[1] Sourced from Fifield (2001) and Landcom (2004).

Table A12 is considered to represent long-term “average” catchment conditions for low to medium gradient slopes (i.e. < 10%). If it is known or expected that soil conditions are likely to be saturated, or near saturated, during the operation of a *Sediment Basin*; or the basin receives runoff from a steep catchment, then the volumetric runoff coefficient should be appropriately adjusted (i.e. increased in value).

Group A soils: soils with very high infiltration capacity. Usually consists of deep (greater than 1 m), well-drained sandy loams, sands or gravels.

Group B soils: soils with moderate to high infiltration capacity. Usually consists of moderately deep (greater than 0.5 m), well-drained medium loamy texture sandy loams, loams or clay loam soils.

Group C soils: soils with a low to moderate infiltration capacity. Usually consists of moderately fine clay loams, or loamy clays, or more porous soils that are impeded by poor surface conditions, shallow depth or a low porosity subsoil horizon.

Group D soils: soils with a low porosity. Usually consists of fine-textured clays, soils with poor structure, surface-sealing (dispersive/sodic) soils, or expansive clays. Included in this group would be soils with a permanent high watertable.

Landcom (2004) provides typical infiltration rates for the various soil hydrologic groups (A, B, C, & D) as presented in Table A13.

Table A13 – Typical infiltrations rates for various soil hydrologic groups ^[1]

| Soil hydrologic group | Typical infiltration rate (mm/hr) | | K _{sat} (mm/hr) ^[2] |
|-----------------------|-----------------------------------|----------|---|
| | Saturated | Dry soil | |
| A | 25 | >250 | >120 |
| B | 13 | 200 | 10–120 |
| C | 6 | 125 | 1–10 |
| D | 3 | 75 | <1 |

Notes: [1] Sourced from Landcom, 2004.

[2] K_{sat} = Saturated hydraulic conductivity

Soil permeability or hydraulic conductivity (K) is a measure of the rate at which gravity can move water vertically through a soil layer with no flow restrictions above or below the soil layer. Compaction under construction traffic can lead to very low conductivity ($K_{\text{sat}} < 0.1$ mm/hr). Charman & Murphy (2007) provides typical values of hydraulic conductivity for various soils (Table A14).

Table A14 – Typical range of hydraulic conductivity for soil horizons

| Texture | ESP (%) | EC (1:5) (dS/m) | Low K_{sat} (mm/hr) | High K_{sat} (mm/hr) |
|-----------------------------|---------|-----------------|------------------------------|-------------------------------|
| Sands | — | — | 120 | > 700 |
| Loamy sands | — | — | 60 | 700 |
| Clayey sands | — | — | 2.5 | 60 |
| Sandy loams | — | — | 5 | 700 |
| Loams | — | — | 5 | 300 |
| Clay loams | < 6 | — | 2.5 | 300 |
| | > 6 | < 0.7 | 0.1 | 2.5 |
| | > 6 | > 0.7 | 5 | 10 |
| | >15 | < 1.9 | 0.1 | 1 |
| | > 15 | > 1.9 | 5 | 10 |
| Light, medium & heavy clays | < 6 | — | 0.5 | 40 |
| | > 6 | < 0.7 | < 0.1 | 2.5 |
| | > 6 | > 0.7 | 5 | 10 |
| | >15 | < 1.9 | < 0.1 | 1 |
| | > 15 | > 1.9 | 5 | 10 |

The coefficients presented in Table A12 apply **only** to the pervious surfaces. Light to heavy clays compacted by construction equipment should attract a volumetric runoff coefficient of 1.0. Loamy soils compacted by construction traffic should attract a volumetric runoff coefficient no less than those values presented for Group D soils.

Catchments with mixed surface areas, such as a sealed road surrounded by soils of varying infiltration capacity, a composite coefficient must be determined using Equation A12.

$$C_{V(\text{comp.})} = \frac{\sum(C_{V,i} \cdot A_i)}{\sum(A_i)} \quad (\text{A12})$$

where:

- $C_{V(\text{comp.})}$ = Composite volumetric runoff coefficient
- $C_{V,i}$ = Volumetric runoff coefficient for surface area (i)
- A_i = Area of surface area (i)

The volumetric runoff coefficient for impervious surfaces directly connected to the drainage system (e.g. sealed roads discharging concentrated flow to a pervious or impervious drainage system) should be adopted as 1.0. The volumetric runoff coefficient for impervious surfaces **not** directly connected to the drainage system (e.g. a footpath or sealed road discharging “sheet” flow to an adjacent pervious surface) should be adopted as the average of the runoff coefficients for the adjacent pervious surface and the impervious surface (assumed to be 1.0).

If the coefficient is being determined for the design of a *Sediment Basin* established within a loamy or clayey soil catchment, then a volumetric runoff coefficient of 1.0 is recommended for all compacted soils and any areas exposed to heavy construction traffic.

A4 Closed conduit (pipe) flow

The following discussion is a brief overview of pipe flow hydraulics. Insufficient information is provided in this appendix to allow inexperienced designers to analyse the hydraulics of permanent pipe drainage systems, or to design such things as a “riser pipe outlet system” for a Type C Sediment Basins.

This discussion only applies to pipes flowing full. The hydraulic analysis of pipe systems flowing partially full can be very complicated and should not be attempted by inexperienced designers.

A4.1 Hydraulic analysis of pipes flowing full

The simplest pipeline system to analyse is the two-tank model as shown in Figure A6.

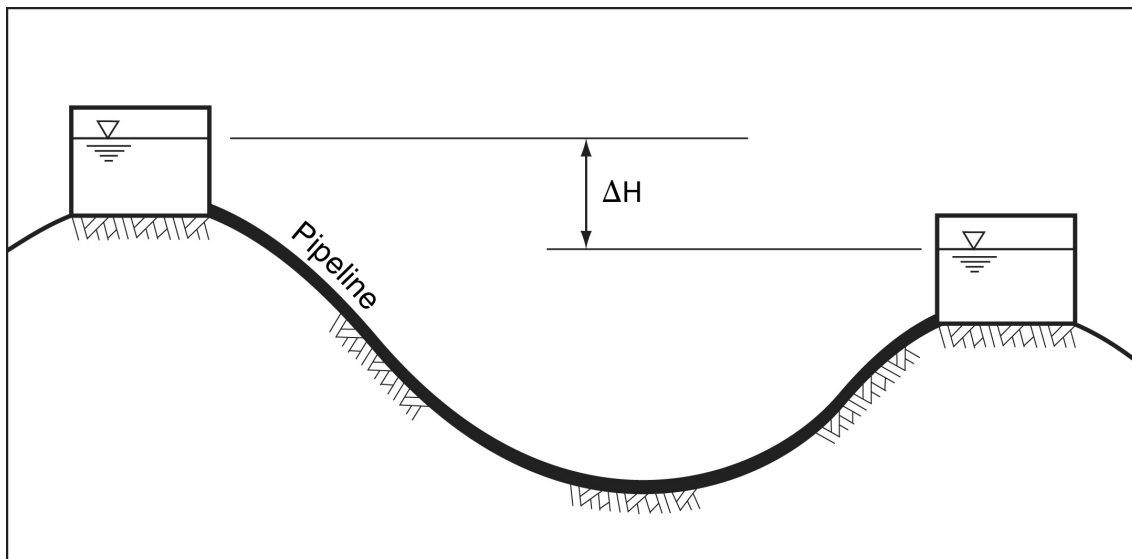

Figure A6 – Pipe flow between two tanks

When flow in the above pipeline system is in equilibrium, then the total energy loss within the pipeline is equal to the different in water level elevation (ΔH) between the two tanks, such that:

$$\Delta H = H_e + H_f + H_{\text{fittings}} + H_{\text{exit}} \quad (\text{A14})$$

The components of energy loss within the pipeline are defined as:

- Entry loss component: $H_e = K_e \cdot (V^2/2g)$ where $K_e = 0.5$ for square edged, unrestricted entry conditions.
- Friction loss component: $H_f = ((2g \cdot L \cdot n^2)/R^{4/3}) \cdot (V^2/2g)$
- Fittings loss component: $H_{\text{fittings}} = \Sigma(K_{\text{fittings}} \cdot (V^2/2g))$
- Exit loss component: $H_{\text{exit}} = K_{\text{exit}} \cdot (V^2/2g)$ where $K_{\text{exit}} = 1.0$ for fully submerged, unrestricted discharge into still water. If the pipe discharges into a flowing channel, then the exit loss may be taken as: $H_{\text{exit}} = (V^2/2g)_{\text{pipe}} - (V^2/2g)_{\text{channel}}$

where:

- H_e = Entry loss [m]
 K_e = Entry loss coefficient
 V = Average flow velocity within a pipe flowing full [m/s]
 g = Acceleration due to gravity [9.8m/s²]
 H_f = Friction loss [m]
 L = Length of pipe of constant cross section [m]
 n = Manning's roughness of the pipe (refer to Table A15)
 R = Hydraulic radius of the internal pipe dimension = $D/4$ [m]
 D = Internal diameter of the pipe [m]
 H_{fittings} = Combined energy loss due to pipe fittings such as bends and valves [m]
 K_{fittings} = Fitting loss coefficient (refer to Table A16)
 H_{exit} = Exit loss [m]
 K_{exit} = Exit loss coefficient

Table A15 – Recommended Manning's roughness values for pipe

| Pipe type | Recommended "n" | Typical range of values |
|---------------------------|-----------------|-------------------------|
| Reinforced concrete | 0.013 | 0.011 to 0.013 |
| Fibre reinforced concrete | 0.011 | 0.010 to 0.011 |
| Corrugated metal | 0.020 | 0.016 to 0.024 |
| uPVC | 0.009 | 0.008 to 0.009 |
| Black Brute or HDPE | 0.013 | 0.009 to 0.015 |

Table A16 – Typical energy loss coefficients for pipe fittings

| Pipe fitting | Energy loss coefficient (K_{fitting}) |
|--|--|
| 90 degree elbow (PVC) | 1.25 |
| 90 degree short radius welded bend (steel) | 0.40 |
| 45 degree elbow (PVC) | 0.50 |
| 45 degree short radius welded bend (steel) | 0.20 |
| 90 degree single mitred bend | 1.20 |
| 90 degree double mitred bend | 0.47 |
| 45 degree mitred bend | 0.34 |
| Butterfly valve (fully open) | 0.3 |
| Gate valve (fully open) | 0.15 to 0.2 |
| Globe valve (fully open) | 10 |
| Swing gate check valve (fully open) | 1.0 to 2.5 |
| Sharp edged entrance | 0.5 |
| Projected entrance | 0.8 |
| Slightly rounded entrance | 0.25 |

It is generally considered that a more reliable estimate of the friction loss component for pipes smaller in diameter than, say 450 mm, can be obtained from the Darcy-Weisbach equation (A15) which incorporates the Colebrook-White friction factor (f).

$$H_f = f.(L/D).(V^2/2g) \quad (\text{A15})$$

A5 Open channel flow

A5.1 Introduction

The analysis of open channel flow is usually required to determine either the depth (y) of water flow at a particular location, or its flow velocity (V). Various analytical procedures and equations have been developed to determine the hydraulic properties of water in motion. The equation most commonly used in Australia is the Manning equation.

Manning's equation, however, is only suitable for use when the water is flowing in a near-uniform condition. That is, the channel has a near-constant cross section, slope and roughness, or where these parameters vary gradually (if at all) along the length of the channel being considered.

On construction sites, it may be necessary to determine flow conditions at a change in grade, e.g. as water passes from a low-gradient *Catch Drain* into a steep *Chute* (Figure A7(b)), or when water discharges from a *Chute* and enters a downstream low-gradient channel (Figure A15). In such circumstances, the water passes through specific hydraulic conditions governed by the flow rate and the channel geometry (i.e. "critical depth" in the first case, and a "hydraulic jump" in the latter case). The hydraulic analysis of these flow conditions can be complicated by a number of factors, all of which can make the science of open channel flow a topic only suitable for analysis by experienced hydraulic engineers.

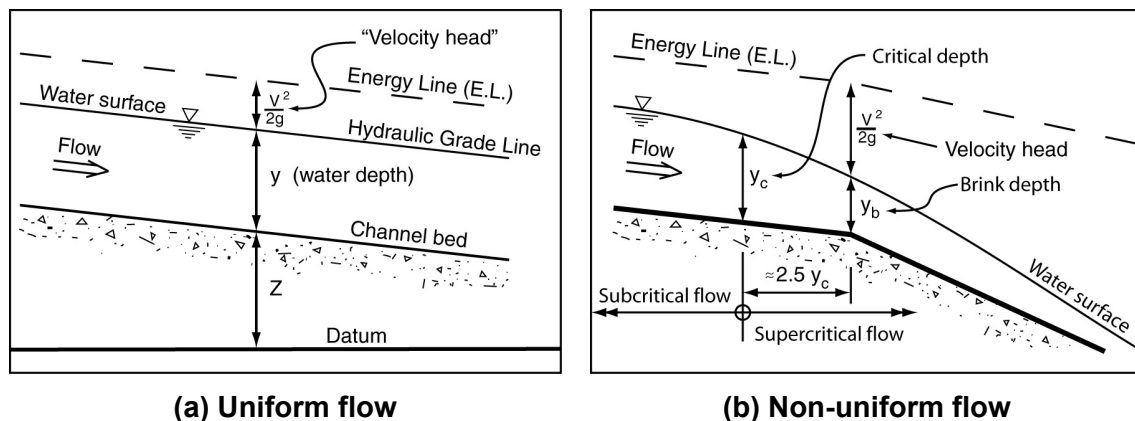

Figure A7 – Example of uniform and non-uniform open channel flow

The information presented within the chapter generally applies only to uniform flow conditions, i.e. where the channel has a near-constant or uniform shape, slope and roughness. Uniform flow conditions are expected to occur within a *Catch Drain* of constant slope, or within a long *Chute* or spillway of constant slope.

Erosion and sediment control practitioners who have not had extensive training in hydraulics should always seek advice from an experienced professional if they are unsure whether Manning's equation can be applied to a particular hydraulic situation.

A5.2 Manning's Equation

Manning's equation is commonly used in Australia for the analysis of open channel flow and for stormwater pipe flow where the diameter of the pipe is typically 450 mm or greater.

$$\text{Manning's equation:} \quad V = (1/n) \cdot R^{2/3} \cdot S^{1/2} \quad (\text{A16})$$

$$\text{Alternatively:} \quad Q = (1/n) \cdot A \cdot R^{2/3} \cdot S^{1/2} \quad (\text{A17})$$

where:

V = Average flow velocity [m/s]

n = Manning's roughness coefficient [dimensionless]

This coefficient accounts not only for the effects of surface roughness, but also for the effects of minor channel irregularities.

R = hydraulic radius = A/P [m]

The hydraulic radius is equal to the cross-sectional area (A) of the flow divided by the wetted perimeter (P) of the flow.

A = Cross-sectional area of the flow [m²]

P = The wetted perimeter is the length of the line of contact between the water and the channel measured at a cross section.

S = Slope of the energy line. In uniform flow the energy line is assumed to have the same slope as the water surface and the channel bed [m/m]

Q = Channel flow rate [m³/s]

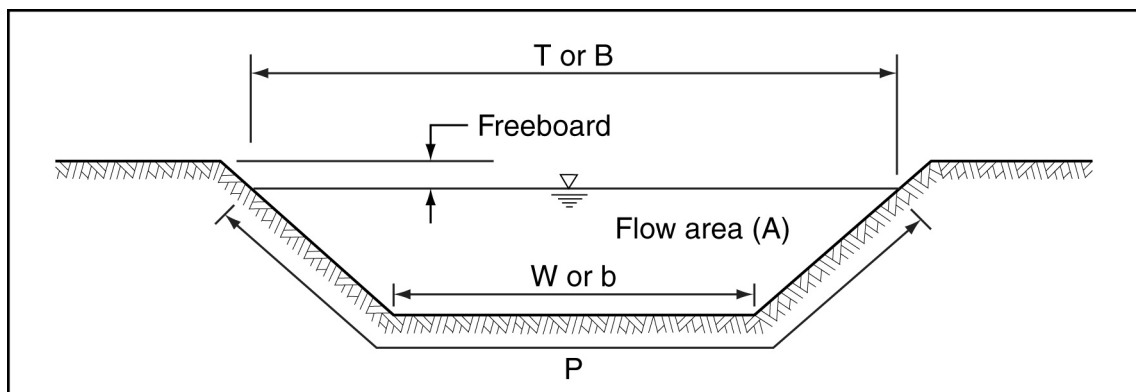

Figure A8 – Channel cross section terminology

Manning's equations can be used to analyse the following flow conditions:

1. To determine what flow rate (Q) will achieve a desirable flow depth (y) for a given channel geometry (A & R), roughness (n) and slope (S).
2. To determine what uniform flow depth will occur within a channel of specified geometry, roughness and slope, for a given flow rate.

The Manning's roughness coefficient "n" is a dimensionless constant. Thus, Manning's "n" values can be obtained from variety of reference documents, including those with English units, without the need for conversion of the units. However, an additional constant (1.486) must be applied to the Manning's equation when using English units.

Tables A17 to A20 provide typical Manning's n values.

Table A17 – Typical Manning's n roughness (Chow, 1959)

| Channel description | Manning's roughness | Channel description | Manning's roughness |
|---------------------------------|---------------------|---------------------------------|---------------------|
| Concrete (smooth) | 0.013 | Winding open soil drain | 0.025 |
| Concrete (rough) | 0.015 | Winding drain, some weeds | 0.032 |
| Precast pipes or culverts | 0.013 | Earth side with rubble bed | 0.030 |
| Asphalt (smooth) | 0.013 | Stony banks, weedy bed | 0.035 |
| Asphalt (rough) | 0.016 | Deep channel, some weeds | 0.050 |
| Excavated open soil drain | 0.020 | Deep channel, dense weeds | 0.080 |
| Straight gravel lined drain | 0.025 | Natural channel with vegetation | 0.100 |
| Straight drain with short grass | 0.030 | Natural channel with vines | 0.200 |

Table A18 – Manning's roughness for various channel linings (Fifield, 2001)

| Material | Flow depth less than 150 mm | Flow depth of 150 to 600 mm | Flow depth greater than 600 mm |
|--------------------------------|---|-----------------------------|--------------------------------|
| Bare, rough-cut soil | 0.023 | 0.020 | 0.020 |
| Plastic sheeting | 0.013 | | |
| Concrete | 0.015 | 0.013 | 0.013 |
| Asphalt | 0.018 | 0.016 | 0.016 |
| Straw (loose) covered with net | 0.065 | 0.033 | 0.025 |
| Jute net | 0.028 | 0.022 | 0.019 |
| Wood excelsior blanket | 0.066 | 0.035 | 0.028 |
| Turf Reinf. Mat – unvegetated | 0.036 | 0.026 | 0.020 |
| Turf Reinf. Mat – grassed | 0.023 | 0.020 | 0.020 |
| Gabion/rock mattress | Manning's roughness as for loose rock assuming, $d_{50}/d_{90} = 0.8$ | | |

Table A19 – Manning's roughness for grassed channels (50–150 mm blade)

| R (m) | Swale Slope (%) | | | | | |
|-------|--------------------|--------------------|-------|-------|-------|-------|
| | 0.1 | 0.2 | 0.5 | 1.0 | 2.0 | 5.0 |
| 0.1 | Outside data range | Outside data range | | 0.105 | 0.081 | 0.046 |
| 0.2 | | 0.091 | 0.068 | 0.057 | 0.043 | 0.030 |
| 0.3 | 0.078 | 0.064 | 0.053 | 0.043 | 0.031 | 0.030 |
| 0.4 | 0.063 | 0.054 | 0.044 | 0.033 | 0.030 | 0.030 |
| 0.5 | 0.056 | 0.050 | 0.038 | 0.030 | 0.030 | 0.030 |
| 0.6 | 0.051 | 0.047 | 0.034 | 0.030 | 0.030 | 0.030 |
| 0.8 | 0.047 | 0.044 | 0.030 | 0.030 | 0.030 | 0.030 |
| 1.0 | 0.044 | 0.044 | 0.030 | 0.030 | 0.030 | 0.030 |
| >1.2 | 0.030 | 0.030 | 0.030 | 0.030 | 0.030 | 0.030 |

Manning's n values in Table A18 may be approximated by Equation A18 (units of R [m] and S [m/m]). Note minimum n = 0.030. Caution use at low hydraulic radius values.

$$n = \frac{R^{1/6}}{51.24 + 20.77 \log_{10}(R^{1.4} \cdot S^{0.4})} \quad (\text{A18})$$

Table A20 – Manning’s roughness of rock lined channels with shallow flow

| | $d_{50}/d_{90} = 0.5$ | | | | | $d_{50}/d_{90} = 0.8$ | | | | |
|------------|-------------------------|------|------|------|------|-------------------------|------|------|------|------|
| $d_{50} =$ | 0.1m | 0.2m | 0.3m | 0.4m | 0.5m | 0.1m | 0.2m | 0.3m | 0.4m | 0.5m |
| R | Manning’s roughness (n) | | | | | Manning’s roughness (n) | | | | |
| 0.2m | 0.06 | 0.10 | 0.14 | 0.17 | 0.21 | 0.03 | 0.06 | 0.08 | 0.09 | 0.11 |
| 0.3m | 0.05 | 0.08 | 0.11 | 0.14 | 0.16 | 0.03 | 0.05 | 0.06 | 0.08 | 0.09 |
| 0.4m | 0.05 | 0.07 | 0.09 | 0.12 | 0.14 | 0.03 | 0.04 | 0.05 | 0.07 | 0.08 |
| 0.5m | 0.04 | 0.06 | 0.08 | 0.10 | 0.12 | 0.03 | 0.04 | 0.05 | 0.06 | 0.07 |
| 0.6m | 0.04 | 0.06 | 0.08 | 0.09 | 0.11 | 0.03 | 0.04 | 0.05 | 0.05 | 0.06 |
| 0.8m | 0.04 | 0.05 | 0.07 | 0.08 | 0.09 | 0.03 | 0.04 | 0.04 | 0.05 | 0.06 |
| 1.0m | 0.03 | 0.04 | 0.06 | 0.07 | 0.08 | 0.03 | 0.03 | 0.04 | 0.05 | 0.05 |

The roughness values presented in Table A20 have been developed from Equation A19 (Witheridge, 2002). Equation A19 may be used to estimate the Manning’s roughness “n” of rock lined channels.

$$n = \frac{(d_{90})^{1/6}}{26(1 - 0.3593^{(x)^{0.7}})} \quad (\text{A19})$$

where: $X = (R/d_{90})(d_{50}/d_{90})$

R = Hydraulic radius of flow over rocks [m]

d_{50} = mean rock size for which 50% of rocks are smaller [m]

d_{90} = mean rock size for which 90% of rocks are smaller [m]

In “natural” gravel-based streams the factor d_{50}/d_{90} is typically in the range 0.2 to 0.5, whereas in constructed channels in which imported graded rock is used, the ratio is more likely to be in the range 0.5 to 0.8.

A5.3 Normal or uniform flow depth

Normal flow (also known as “uniform flow”) is the flow condition achieved by a fluid when it passes down a long, straight, uniform cross-sectional channel of constant slope. During these conditions the slope of the total energy line (S) is the same as the slope of the water surface (the “hydraulic grade line”, or HGL) and the slope of the channel bed (S_o) as shown in Figure A9.

Normal depth (y_n) is the water depth that occurs during conditions of uniform flow within an open channel. Normal depth may be determined by either using Manning’s equation, using non-dimensional design charts (e.g. Chow, 1959), or by using a variety of computer programs.

Hand calculations using Manning’s equation often require trial and error procedures involving firstly the selection of a trial water depth (y) followed by testing to see if the associated cross-sectional parameters of area (A), wetted perimeter (P) and hydraulic radius (R) satisfy the equation.

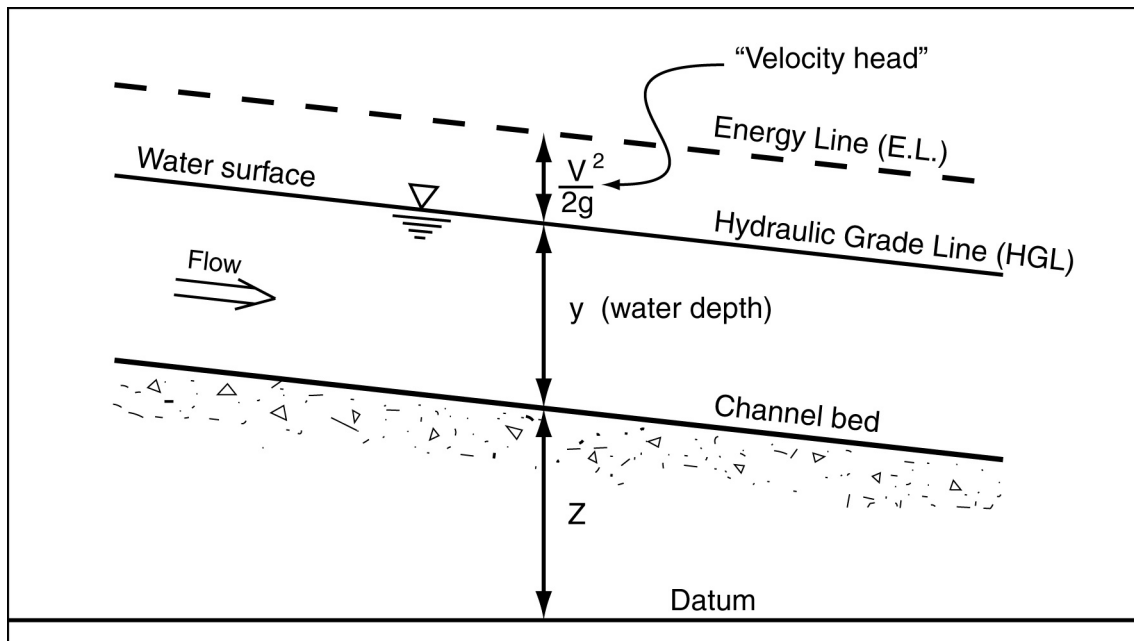

Figure A9 – Uniform flow conditions

Example A4

Problem:

Water is flowing at a rate of 4.5 m³/s within a trapezoidal channel. The bottom width is 2.4 m and side slope is 2:1(H:V). Compute the normal depth (y_n) if Manning's roughness $n = 0.012$ and $S_o = 0.0001$.

Solution:

$$Q = (1/n) A R^{2/3} S^{1/2}$$

Replace $R = A/P$ $(Q \cdot n)/S^{1/2} = A^{5/3}/P^{2/3}$

Using the channel geometry equations presented in Table A30 with bank slope, $m = 2$:

$$A = (b + m \cdot y_n) y_n = (2.4 y_n + 2 y_n^2)$$

$$P = (b + 2 y_n (1 + m^2)^{1/2}) = (2.4 + 2 y_n (1 + 4)^{1/2})$$

Given: $Q = 4.5$ m³/s, $b = 2.4$ m, $m = 2$, $n = 0.012$, $S = S_o = 0.0001$, then:

$$(Q n)/S^{1/2} = (4.5 \times 0.012)/(0.0001)^{1/2} = A^{5/3}/P^{2/3}$$

And by trial and error: $y_n = 1.28$ m

The complexity of the above worked example clearly demonstrates why few hydraulic engineers still do these calculations by hand. The above example is more readily solved using non-dimensional charts such as provided in Chow (1959) or commercial software packages.

A5.4 Critical depth and weir flow

The concept of "critical flow" is one of the most important aspects of open channel flow. In hydraulic terms, critical flow in water is similar to the concept of the sound barrier in aeronautical engineering. The difference is that the sound barrier represents the speed of "sound" in air, while critical flow represents the speed of the "pressure wave" in water.

Water flow less than the speed of the pressure wave is referred to as “subcritical flow”, and water flow greater than the speed of the pressure wave is referred to as “supercritical flow”.

Technical Note A1 – Subcritical, critical and supercritical flow

The speed of the pressure wave in water is important because it relates to the speed that the “backwater effects” of a sudden change in flow conditions can travel up the channel. For example, if you throw a stone into a pool of still water, waves will radiate out from the splash point at the speed of the pressure wave. This speed is proportional to the square root of gravity times the depth of the water (i.e. \sqrt{gy}).

If we throw a stone into a stream of flowing water, then the induced waves will move up stream at a speed of the pressure wave minus the flow velocity of the water; however, waves will move downstream at the speed of the pressure wave plus the speed of the water. Now, if the stream was flowing at its “critical velocity”, then waves from the splash would not be able to move upstream.

Thus when water is flowing at a speed greater than the critical velocity (i.e. supercritical flow), water depth within the channel is governed by flow conditions *upstream* of the point of interest. Conversely, when water is flowing at a speed less than the critical velocity (i.e. subcritical flow), water depth within the channel is governed by flow conditions *downstream* of the point of interest. This latter condition is referred to as “backwater” conditions, i.e. when water depth and flow velocity within a channel are governed by flow conditions downstream of the point of interest.

When water flowing at subcritical velocity moves from a low gradient channel into a steep channel where it will flow at supercritical velocity, it must pass through critical flow conditions resulting in a flow depth known as “critical depth”. Such conditions are demonstrated in Figure A10.

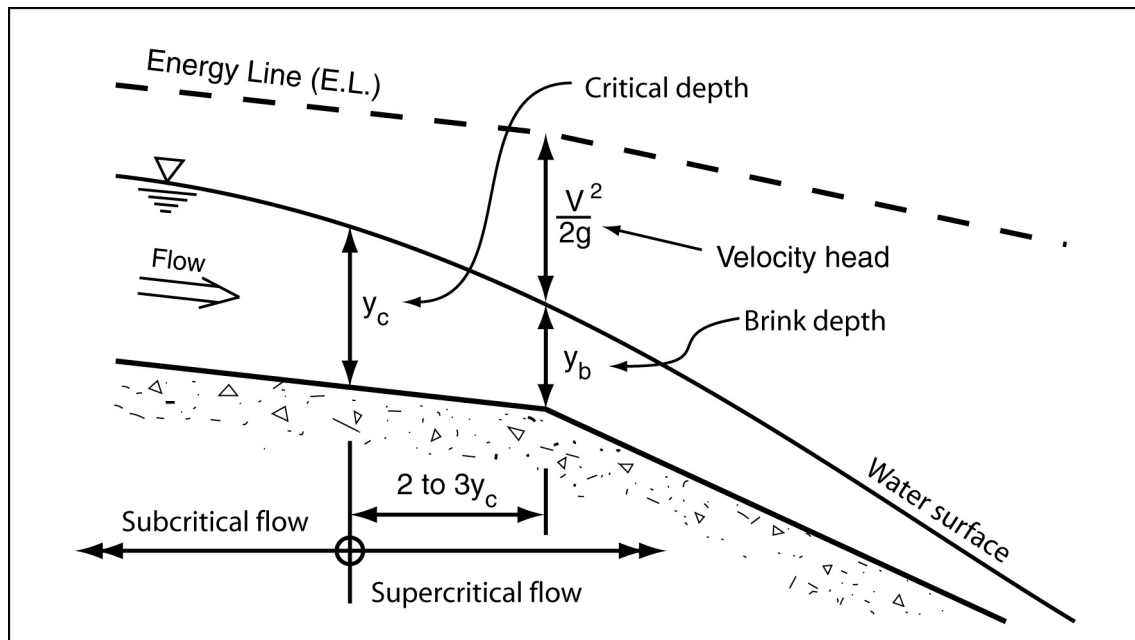

Figure A10 – Water passing through critical velocity as it enters a steep Chute

Generally it is assumed that critical depth occurs at the edge of the *Chute*; however, in certain circumstances (as presented in Figure A10), critical depth may actually occur slightly upstream causing the flow depth at the edge of the chute (the brink depth) to be slightly less than critical depth.

Critical depth is a useful parameter because there are unique hydraulic properties associated with this flow condition that are independent of surface roughness and channel slope. Critical depth is most commonly used to develop weir flow equations such as those used in the design of *Sediment Basin* spillways.

Critical depth (y_c) within a “rectangular” channel containing a constant flow per unit width (q) occurs when:

$$y_c = (q^2/g)^{1/3} = (2/3)H \quad (A20)$$

$$V_c = (g \cdot y_c)^{1/2} = (g \cdot q)^{1/3} \quad (A21)$$

For “non-rectangular” channels, critical depth is assumed to occur when:

$$Q^2 T = g A^3 \quad (A22)$$

where:

y_c = critical depth [m]

V_c = average flow velocity at location of critical depth [m/s]

q = flow per unit width (rectangular flow only) [$m^3/s/m$]

g = gravity [$9.8m/s^2$]

Q = total channel flow rate [m^3/s]

T = top width of the water surface [m]

A = flow area [m^2]

The layout of a typical *Sediment Basin* spillway consists of flow passing from the settling pond into a short “approach channel” (Figure A11) that directs the water towards the spillway crest. Flow then passes down the steep chute towards an energy dissipater located at the base of the chute.

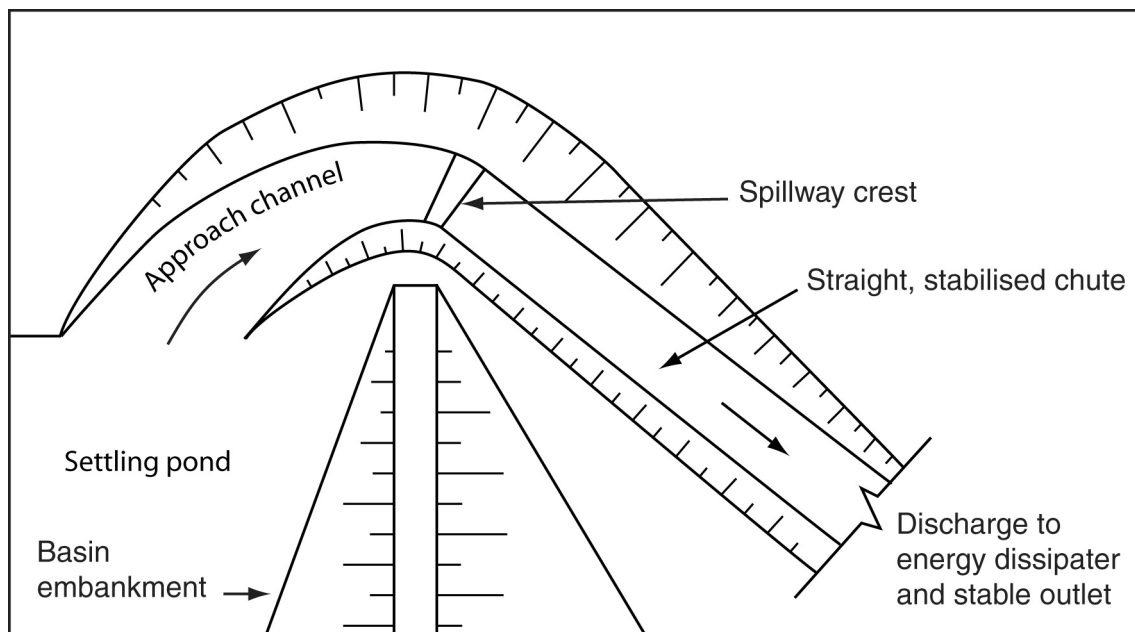

Figure A11 – Typical layout for an emergency spillway adjacent an earth fill *Sediment Basin* embankment

If the spillway crest length (L) and its approach channel are short, then friction loss upstream of the spillway crest can be ignored and the water level within the *Sediment Basin* “ H ” (relative to the spillway crest) can be determined directly from the appropriate weir equation. Figure A12 shows flow approaching a spillway crest.

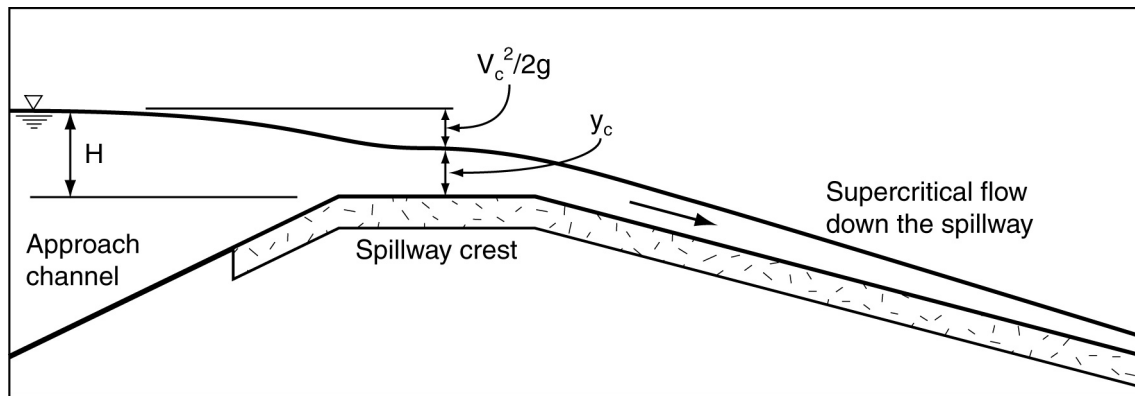

Figure A12 – Hydraulic profile for spillway crest where friction loss within the approach channel is insignificant

In such cases the upstream water level (H) relative to the weir crest may be determined from the equations presented in Table A21.

Table A21 – Weir equations for short spillway crest length where friction loss in the approach channel is negligible

| Weir cross sectional profile | Side slope (H:V) | Weir equation |
|---|------------------|--------------------------------------|
| Rectangular (b = base width) | vertical sides | $Q = 1.7 b H^{1.5}$ |
| Triangular | $m:1$ | $Q = 1.26 m H^{2.5}$ |
| Trapezoidal where : b = base width and m = side slope | 1:1 | $Q = 1.7 b H^{1.5} + 1.26 H^{2.5}$ |
| | 2:1 | $Q = 1.7 b H^{1.5} + 2.5 H^{2.5}$ |
| | 3:1 | $Q = 1.7 b H^{1.5} + 3.8 H^{2.5}$ |
| | 4:1 | $Q = 1.7 b H^{1.5} + 5.0 H^{2.5}$ |
| | $m:1$ | $Q = 1.7 b H^{1.5} + 1.26 m H^{2.5}$ |

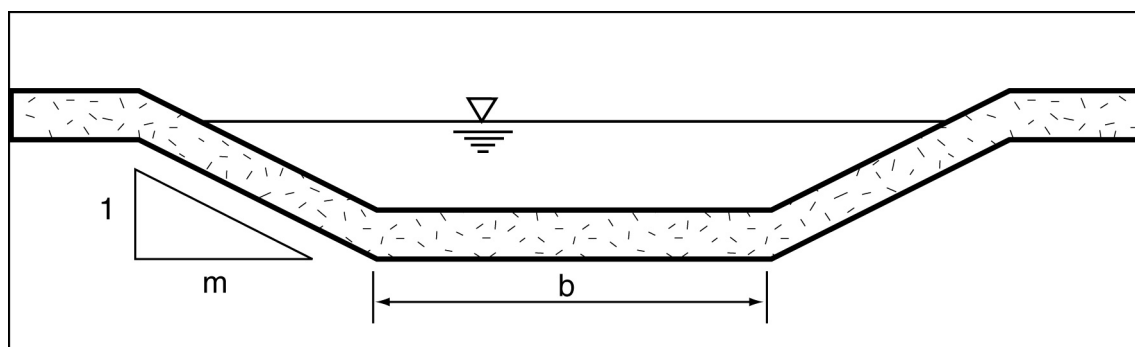

Figure A13 – Trapezoidal spillway (weir) crest

In most *Sediment Basin* spillways, however, friction loss within the approach channel is significant and cannot be ignored. In such cases an allowance must be made for this friction loss when determining the relationship between basin water level and spillway discharge. Figure A14 shows flow approaching a spillway crest where friction loss within the approach channel is significant.

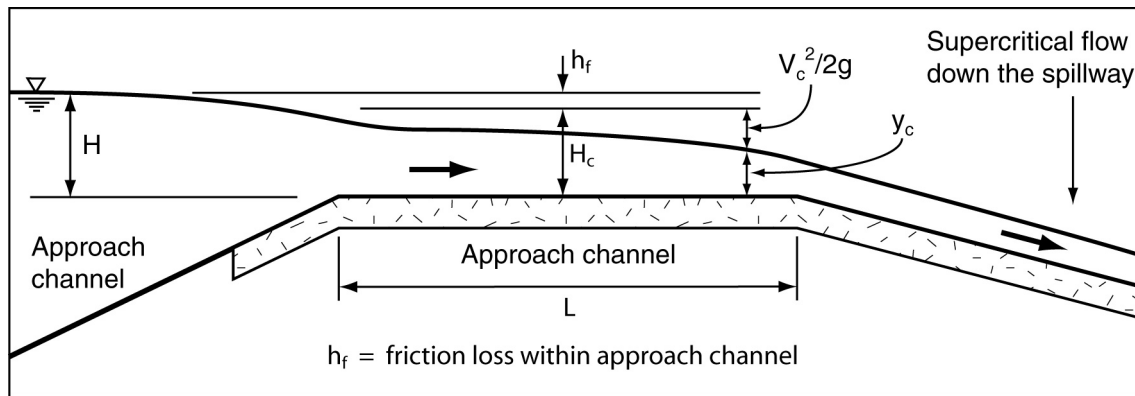

Figure A14 – Hydraulic profile for a spillway where friction loss within the approach channel is significant

A numerical backwater model, such as HecRas, should be used to determine the water level profile along the length of the approach channel and thus the anticipated maximum water level within a *Sediment Basin*. Such models can also be used to determine flow velocities down the face of the spillway chute. Alternatively, water levels within the basin (H) relative to the spillway crest may be determined from Equation A23.

$$H = H_c + h_f \quad (\text{A23})$$

where:

H = water level within *Sediment Basin* relative to spillway crest [m]

H_c = total head (energy level) at the spillway crest = $y_c + V_c^2/2g$ [m]

y_c = critical depth at spillway crest [m]

V_c = critical flow velocity at spillway crest [m/s]

g = acceleration due to gravity = 9.8 m/s^2

h_f = friction loss within the approach channel and across the crest width [m]

Friction loss (h_f) within the approach channel can be estimated using Equation A24.

$$h_f = \frac{V^2 n^2 L}{R^{4/3}} \quad (\text{A24})$$

where:

V = average flow velocity within the approach channel (if unknown, then assume a velocity of half the critical flow velocity (V_c)) [m/s]

n = Manning's roughness of the approach channel

L = length of the approach channel upstream of the spillway crest [m]

R = average hydraulic radius of the approach channel [m]

In circumstances where friction within the approach channel is significant, but the determination of peak water level within the *Sediment Basin* is not critical, the total upstream head (H) may be **estimated** from the equations presented in Table A22.

Table A22 – Approximate weir equations for spillways with a long approach channel where friction loss is significant

| Weir cross sectional profile | Side slope (H:V) | Weir equation |
|------------------------------|------------------|-------------------------------------|
| Rectangular (b = base width) | N/A | $Q = 1.6 b H^{1.5}$ |
| Triangular | m:1 | $Q = 1.2 m H^{2.5}$ |
| Trapezoidal (b = base width) | m:1 | $Q = 1.6 b H^{1.5} + 1.2 m H^{2.5}$ |

Hydraulically, a *Check Dam* (Figure A15) is simply a weir placed within a channel to control upstream flow velocities and thus reduce the risk of channel erosion. The hydraulics of a *Check Dam* can usually be analysed using a trapezoidal weir equation.

The hydraulics of the *Check Dam* may be assessed using Equation A25. Note; the base width of the trapezoidal weir (b) is taken as the effective crest width (W) of the *Check Dam*. If the crest of the *Check Dam* is heavily curved, then the head (H) versus discharge (Q) relationship presented in Equation A25 should only be taken as an approximation.

$$Q = (1.7 W H^{1.5}) + (1.26 m H^{2.5}) \quad (\text{A25})$$

The above equation can be used to check that a proposed *Check Dam* does not cause channel flow upstream of the *Check Dam* to overtop the channel banks (i.e. “H” does not exceed “d”).

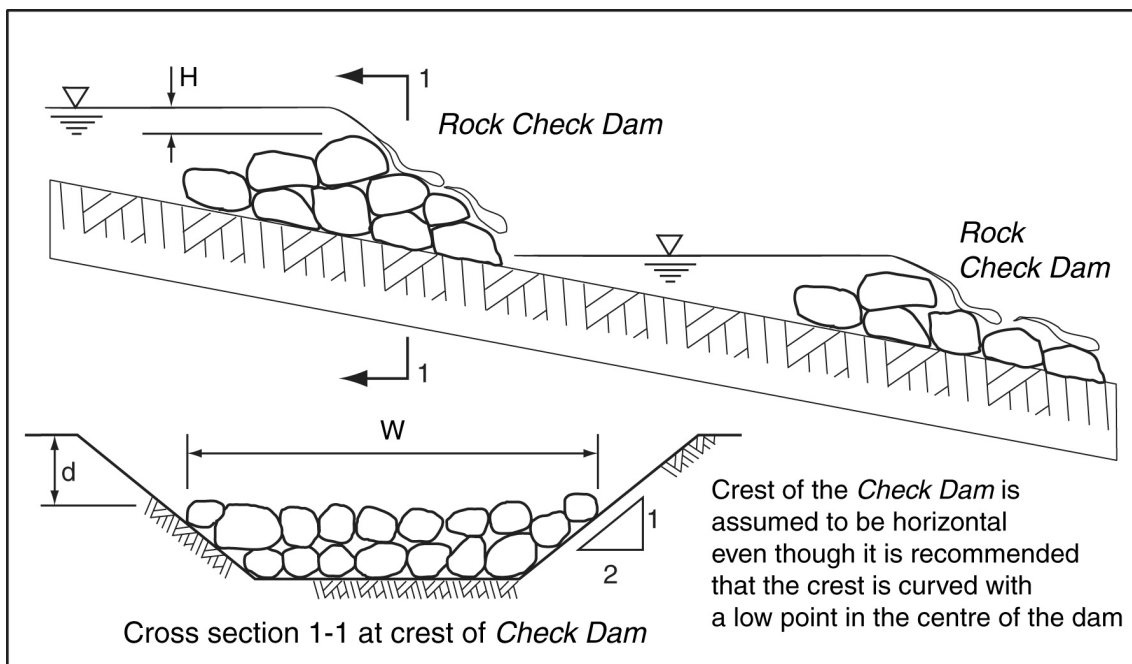

Figure A15 – Assumed hydraulics of a *Check Dam*

A5.5 Hydraulic jumps

A hydraulic jump (Figure A16) occurs when supercritical flow at the base of a steep channel enters a low gradient channel and converts back to subcritical flow. Significant energy loss can occur within a hydraulic jump and thus their existence is often encouraged at the base of *Chutes* and spillways to dissipate excess energy.

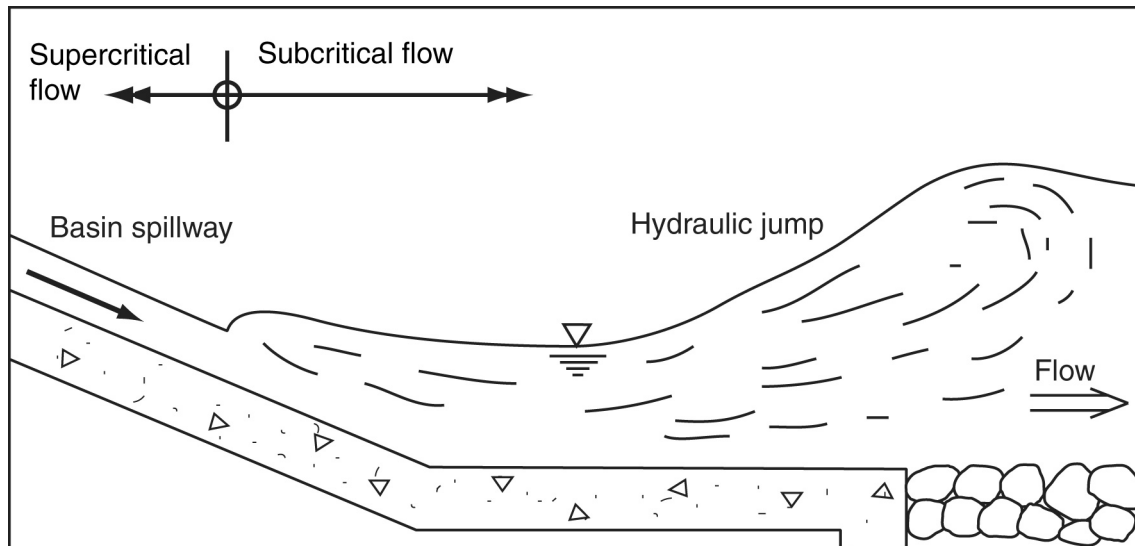

Figure A16 – Hydraulic jump at base of *Sediment Basin* spillway

A5.6 Allowable flow velocity

Catch Drains, *Diversion Channels*, *Chutes* and spillways are all designed to limit the maximum flow velocity to a value not exceeding the allowable or permissible flow velocity for the specified channel lining.

Allowable flow velocities for various open soil and channel linings are provided in Tables A23 to A27. Allowable flow velocities for grass lined channels are provided in Table A28.

Table A23 – Allowable flow velocity for various channel linings

| Type | Description | Allowable velocity | Comments |
|----------------------------------|---|--|---|
| Open earth (unlined channels) | Extremely erodible soils | 0.3 m/s | <ul style="list-style-type: none"> Dispersive clays are highly erodible even at low flow velocities and therefore must be either treated (e.g. with gypsum) or covered with a minimum 100 mm of stable soil. Highly erodible soils may include: Lithosols, Alluvials, Podzols, Siliceous sands, Soloths, Solodized solonetz, Grey podzolics, some Black earths, fine surface texture-contrast soils and Soil Groups ML and CL. Moderately erodible soils may include: Red earths, Red or Yellow podzolics, some Black earths, Grey or Brown clays, Prarie soils and Soil Groups SW, SP, SM, SC. Erosion-resistant soils may include: Xanthozem, Euchrozem, Krasnozems, some Red earth soils and Soil Groups GW, GP, GM, GC, MH and CH (also refer to Appendix C). |
| | Sandy soils | 0.45 m/s | |
| | Highly erodible soils | 0.4 to 0.5 m/s | |
| | Sandy loam soils | 0.5 m/s | |
| | Moderately erodible soils | 0.6 m/s | |
| | Silty loam soils | 0.6 m/s | |
| | Low erodible soils | 0.7 m/s | |
| | Firm loam soils | 0.7 m/s | |
| Stiff clay very colloidal soils | 1.1 m/s | | |
| Erosion Control Blankets | Thin jute blankets | Very low, say < 1 m/s | <ul style="list-style-type: none"> Temporary embankment liner. Generally not suitable for use in channels with any significant flow velocity. Used in recently seeded, low-velocity, grassed overland flow paths. |
| | Thick jute (weed control) blankets | 1.4 m/s | <ul style="list-style-type: none"> If a temporary channel liner is required, then the use of a synthetic filter cloth or jute mesh may be preferred instead of a thick jute blanket. Jute products have the advantage of being readily biodegradable. Typical design life of around 3 months. |
| | Coir blankets | Medium, say 1.5 m/s | <ul style="list-style-type: none"> Temporary channel liner. Design life of 1 to 2 years depending on degree and duration of water saturation. Shear strength and resistance to flow velocity decreases with age. |
| | Composite biodegradable blankets reinforced with non UV-stabilised synthetic mesh | 1.6 to 3.6 m/s (Refer to Table A25) | <ul style="list-style-type: none"> Refer to manufacturer's testing and design data. Used on newly seeded channels. Allowable flow velocity depends on soil erodibility and strength of the mat. Maximum channel grade of 4 to 6% depending on the strength of the mat. Warning: wildlife (e.g. birds and reptiles) can become entangled in the mesh. Generally not suitable for use in or around wildlife or bushland areas. |

Table A24 – Allowable flow velocity for various channel linings

| Type | Description | Allowable velocity | Comments |
|---|--------------------------------|--|--|
| Erosion control mesh | Jute mesh | 1.3 to 1.7 m/s | <ul style="list-style-type: none"> • Typical design life of 1 year. • Used on newly seeded channels. • The exposed underlining soil may be susceptible to raindrop impact erosion unless the mesh is sprayed with a soil-stabilising agent such as anionic bitumen emulsion. |
| | Jute mesh sprayed with bitumen | 1.3 to 2.3 m/s (Refer to Table A25) | <ul style="list-style-type: none"> • Typical design life of 1 year. • Used on newly seeded channels. • Allowable flow velocity depends on the soil's erosion resistance. • The application of bitumen emulsion controls raindrop impact erosion, protects the grass seed, and limits moisture loss. |
| | Coir mesh | 1.7 m/s (Refer to Table A25) | <ul style="list-style-type: none"> • Typical design life of 1 to 2 years. • Biodegradable after 4 to 10 years. • Used on newly seeded channels. • Exposed underlining soil may be susceptible to raindrop impact erosion unless stabilised with anionic bitumen emulsion, a light jute blanket or mulch. The latter option is preferred when used on waterway banks. |
| | Synthetic mesh | Low to medium | <ul style="list-style-type: none"> • Temporary channel liner. • Used on newly seeded channels. • Similar properties to some temporary <i>Erosion Control Mats</i>. |
| Non-woven, un-reinforced filter cloth | Various fabric grades | Medium | <ul style="list-style-type: none"> • Temporary channel/chute liner. • Can be a very effective liner on temporary <i>Chutes</i>. • Minimum 'bidim' A24 or equivalent. • Assume an allowable velocity of 1.0 m/s when placed on medium erodible soils, and 1.5 m/s when placed on low erodible soils. |
| Sediment Fence fabric | Woven or non-woven fabric | Medium to high | <ul style="list-style-type: none"> • Temporary chute liner. • The fabric generally has insufficient width to be used effectively as a temporary channel liner. • Flow can get under the fabric causing erosion. |
| Established grass (Refer to Table 4.19f) | Easily erodible soils | 1.0 to 1.5 m/s | <ul style="list-style-type: none"> • Easily eroded soils include: black earths and fine surface texture-contrast soils. • Used in permanent channels. • Long establishment time when seeded. |
| | Erosion resistant soils | 1.5 to 2.0 m/s | <ul style="list-style-type: none"> • Erosion-resistant soils include: krasnozems and red earth soils. • Used in permanent channels. • Long establishment time when seeded. |

Table A25 – Allowable flow velocity for temporary channel linings

| Anticipated inundation = Soil erodibility = | Less than 6 hours | | | Less than 24 hours | | |
|--|-------------------|--------|------|--------------------|--------|------|
| | Low | Medium | High | Low | Medium | High |
| Plastic fibres with netting | 5.0 | 5.0 | 5.0 | 3.6 | 3.6 | 3.6 |
| Jute or coir mesh sprayed with bitumen, and Coconut/jute fibre mats | 2.3 | 2.0 | 1.7 | 1.7 | 1.5 | 1.3 |

Source: Landcom, 2004.

Table A26 – Allowable flow velocity for various channel linings

| Type | Description | Allowable velocity | Comments |
|------------------------------|---|--|--|
| Turf | | 1.5 to 2.0 m/s | <ul style="list-style-type: none"> Used in permanent channels. Newly laid turf should be anchored with wooded pegs if medium to high flow velocity is possible in the first 2 weeks. |
| Structural soil | Min. 100 mm thick layer of uniform aggregate mixed with soil and grass seeded | Medium | <ul style="list-style-type: none"> Used as a permanent liner for trafficable drainage swales. Surfaces subject to light vehicular traffic. The weight of light vehicles is supported by aggregate to aggregate interaction, thus avoiding compaction of the inter-void soil. |
| Loose rock | | Allowable velocity varies with rock size and channel slope | <ul style="list-style-type: none"> Used mainly as a liner for <i>Chutes</i>. Rock must be recessed below the surrounding ground to allow flow to freely enter the <i>Chute</i>. Considerable care must be taken around the edges of the <i>Chute</i> to control water damage. Subject to weed invasion unless lightly soiled and pocket planted after placement. Requires an underlying filter cloth unless voids are filled with soil and pocket planted. On low gradient channels the allowable velocity, $V(\text{m/s}) = 0.158(d_{50})^{0.5}$ where d_{50} is the mean rock size (mm). |
| Cellular Confinement Systems | Filled with soil | Refer to allowable flow velocity for open soil | <ul style="list-style-type: none"> Used to form <i>Chutes</i>. Useful in arid and semi-arid areas when long-term vegetation cover is not an option, or when suitable large rock is not available. Light and easy to transport to the site. Subsoil drainage problems can exist unless the sidewalls of the <i>Cellular Confinement System</i> are perforated. <i>Cellular Confinement Systems</i> placed within a curved channel can lift from the ground if not adequately anchored. Requires good surface preparation. |
| | Filled with rock | Allowable velocity varies with rock size and channel slope | |

Table A27 – Allowable flow velocity for various channel linings

| Type | Description | Allowable velocity | Comments |
|--|---|--|--|
| Permanent Turf Reinforcing Mats (TRMs) | Open face 2D synthetic mats | 2.4 to 3.0 m/s | <ul style="list-style-type: none"> Refer to manufacturer's data. May be damaged by grass fires. Difficult to recover and reuse topsoil when reforming the channel. |
| | Biodegradable mulch mats reinforced with UV-stabilised mesh | 2.1 to 6.0 m/s | <ul style="list-style-type: none"> Refer to manufacturer's data. Temporary control over raindrop impact and protection of grass seed. Long-term reinforcement of grass, but can be subject to damage during periods of drought if the grass surface is damaged or lost. May be damaged by grass fires. Difficult to recover and reuse topsoil when reforming channel. |
| | 3D, fully synthetic, UV-stabilised mats on vegetated ground | 5.5 m/s for 30 min duration to 3 m/s for 50 hours duration | <ul style="list-style-type: none"> Refer to manufacturer's data. Long-term protection of soil surface. May be damaged by grass fires. Difficult to recover and reuse topsoil when reforming channel. |
| | 3D synthetic mats reinforced with rock fall netting | Assume as above unless supported by testing | <ul style="list-style-type: none"> Refer to manufacturer's data. Used in high velocity channels. Rock fall netting reduces the risk of the mat lifting and folding during high velocity flow. |
| Rock filled mattresses | Mattress thickness typically varies from 0.15 to 0.3 m | 3.5 to 5.0 m/s | <ul style="list-style-type: none"> Refer to manufacturer's data. Used on <i>Sediment Basin</i> spillways. Allowable flow velocity depends on thickness. Long-term applications may be subject to weed infestation unless suitably vegetated. |
| Interlocking turf reinforcing systems | Various commercial concrete modular products | 4.0 to 11.0 m/s | <ul style="list-style-type: none"> Refer to manufacturer's data. Subject to weed infestation unless suitably vegetated. Not suitable in wildlife habitat streams. |
| Impervious liners | Plastic sheeting | High | <ul style="list-style-type: none"> Used as a short-term <i>Chute</i> liner. Often damaged by undermining erosion caused by water passing under the impervious liner. |
| | Bitumen | High | <ul style="list-style-type: none"> Used as a medium-term <i>Chute</i> liner. Generally not suitable for long-term use due to the deterioration of the bitumen and weed infestation into the cracked surface. |
| | Concrete | 7.0 m/s | <ul style="list-style-type: none"> Used as a permanent <i>Chute</i> or spillway liner. Like all channel liners, concrete should not be placed directly onto a dispersive soil. |

Table A28 – Allowable flow velocity (m/s) for consolidated bare earth channels and grassed channels

| Channel Gradient (%) | Percentage of stable vegetal cover ^[1] | | | |
|--------------------------------|---|-----|-----|-----|
| | 0 ^[2] | 50 | 70 | 100 |
| Erosion-resistant soils | | | | |
| 1 | 0.7 | 1.6 | 2.1 | 2.8 |
| 2 | 0.6 | 1.4 | 1.8 | 2.5 |
| 3 | 0.5 | 1.3 | 1.7 | 2.4 |
| 4 | | 1.3 | 1.6 | 2.3 |
| 5 | | 1.2 | 1.6 | 2.2 |
| 6 | | | 1.5 | 2.1 |
| 8 | | | 1.5 | 2.0 |
| 10 | | | 1.4 | 1.9 |
| 15 | | | 1.3 | 1.8 |
| 20 | | | 1.3 | 1.7 |
| Easily eroded soils | | | | |
| 1 | 0.5 | 1.2 | 1.5 | 2.1 |
| 2 | 0.5 | 1.1 | 1.4 | 1.9 |
| 3 | 0.4 | 1.0 | 1.3 | 1.8 |
| 4 | | 1.0 | 1.2 | 1.7 |
| 5 | | 0.9 | 1.2 | 1.6 |
| 6 | | | 1.1 | 1.6 |
| 8 | | | 1.1 | 1.5 |
| 10 | | | 1.1 | 1.5 |
| 15 | | | 1.0 | 1.4 |
| 20 | | | 0.9 | 1.3 |

Notes: [1] Designers should assess the percentage of stable vegetal cover likely to persist under design flow conditions. However it should be assumed that under average conditions the following species are not likely to provide more than the percentage of stable vegetal cover indicated:

- Kikuyu, Pangola and well maintained Couch species – 100%
- Rhodes Grass, poorly maintained Couch species – 70%
- Native species, tussock grasses – 50%

[2] Applies to surface consolidated, but not cultivated

Source: Adapted from Queensland Department of Primary Industries (1992)

Example A5**Problem:**

Design an earth-lined channel of trapezoidal cross-section to carry 0.4 m³/s.

Solution:

Select a Manning's "n" for an earth lined channel, n = 0.02 (Table A17).

Nominate a maximum allowable velocity of 0.5 m/s for a sandy loam soil (Table A23).

Estimate the flow area, $A = Q/V = 0.4/0.5 = 0.8 \text{ m}^2$.

As a first trial let the area = 0.9 m². Note, a slightly larger flow area has been nominated to ensure the flow velocity is less than the maximum allowable. Such a conservative response is personal choice and is not always necessary.

Select trial dimensions of the channel. Given area = 0.9 m², try depth = 0.3 m and channel side slope be 1 in 3. From Table A30, the area of a trapezoidal channel is given by the formula:

$$A = y(b + my) = 0.3(b + 3(0.3)) = 0.9 \text{ m}^2$$

Therefore: b = 2.1 m (first trial)

Determine the wetted perimeter (P). From Table A30, the wetted perimeter of a trapezoidal channel is given by the formula:

$$P = b + 2y(1 + m^2)^{1/2} = 2.1 + 2(0.3)(1 + 3^2)^{1/2} = 4.0 \text{ m}$$

Determine the hydraulic radius (R).

$$R = A/P = 0.9/4.0 = 0.225 \text{ m}$$

Determine the flow velocity for the given discharge and nominated flow area.

$$V = Q/A = 0.4/0.9 = 0.444 \text{ m/s}$$

Using the Manning Equation determine the channel slope (S).

$$V = (1/n)R^{2/3}.S^{1/2} = 0.444 = (1/0.02)(0.225)^{2/3}.S^{1/2}$$

Therefore the required bed slope is: S = 0.00058 (m/m)

Check: $Q = (1/n) A R^{2/3} S^{1/2} = (1/0.02) (0.9) (0.225)^{2/3} (0.00058)^{1/2} = 0.4 \text{ m}^3/\text{s}$ OK

Results:

Channel base width, b = 2.1 m; flow depth, y = 0.3 m; side slope 1 in 3, channel slope S = 0.00058 m/m, constructed channel depth = 0.3 + 0.15 m (for freeboard) = 0.45 m.

Example A6**Problem:**

Design a steep grass lined channel given $Q = 3 \text{ m}^3/\text{s}$, and bed slope of $S = 5\%$.

Solution:

From Table A27, permissible velocity for an easily eroded soil is 1.6 m/s.

Calculate the minimum required flow area, $A = Q/V = 3/1.6 = 1.88 \text{ m}^2$.

If we limit the flow depth to 200 mm, then the average channel width = $1.88/0.2 = 9.4 \text{ m}$.

However, at this stage we do not know what the actual flow depth (y) will be.

Thus try a bed width of 10 m and a bank slope of 1 in 4, (i.e. 4H:1V).

Given the wide shallow channel, assume $R_h = y = \text{say } 200 \text{ mm}$ (first guess)

From Table A19 assume a Manning's roughness, $n = 0.03$

Flow area: $A = y(b + my) = y(10 + 4y)$

Wetted perimeter: $P = b + 2y(1 + m^2)^{1/2} = 10 + 2y(1 + 4^2)^{1/2}$

Hydraulic radius (Table A30):

$$R = \frac{A}{P} = \frac{y(10+4y)}{10+2y\sqrt{(1+16)}}$$

Manning's equation: $V = (1/n).R^{2/3}.S^{1/2} = 1.6 = (1/0.03).R^{2/3}.(0.06)^{1/2}$

By trial and error, $y = 0.14 \text{ m}$

We now need to check our assumed Manning's roughness:

At a flow depth of 0.14m the hydraulic radius, $R = 0.13 \text{ m}$ this is less than the assumed 0.2 m so we need to check the Manning's roughness using Table A19 or Equation A17.

New estimate of Manning's roughness, $n = 0.045$

By trial and error, a new estimate of flow depth, $y = 0.17 \text{ m}$

This has again changed our Manning's roughness values, so let $n = 0.04$

By trial and error, a new estimate of flow depth, $y = 0.16 \text{ m}$

Add 0.15m freeboard to flow depth to determine a bank height of 0.31 m

Calculate a top flow width, $T = b + 2my = 10 + 2(4)0.16 = 11.3 \text{ m}$

Calculate the top width of the constructed channel = $b + 2m(y+0.15) = 12.5 \text{ m}$

Results:

Construct a channel with base width, $b = 10 \text{ m}$; slide slope, 1 in 4; and total depth of 0.31 m allowing for 150 mm freeboard.

A6 Summary of open channel and pipe hydraulics

Table A29 and Figures A17 to A19 summarise the key design equations used in the analysis for various ESC measures.

Table A29 – Summary of key hydraulic equations

| Technique | Component | Equations |
|---|--|--|
| Catch Drain, Flow Diversion Channel, and Flow Diversion Banks | Channel capacity and maximum flow velocity (note: design freeboard of 150 mm) | Manning's equation: $Q = (1/n) A R^{2/3} S^{1/2}$ $V = (1/n) R^{2/3} S^{1/2}$ |
| Check Dam | Water level upstream of the <i>Check Dam</i> | Use an appropriate weir flow equation to determine the upstream water level (H) relative to the crest of the <i>Check Dam</i> , e.g. $Q = (1.7.b.H^{1.5}) + (1.26mH^{2.5})$ |
| Chute or spillway | Maximum water level upstream of the crest of the <i>Chute</i> or spillway | Use an appropriate weir flow equation to determine the maximum water level (H) relative to the crest of the <i>Chute</i> , from Table A20 or Table A21. |
| | Maximum flow velocity down the <i>Chute</i> or spillway | Manning's equation: $V = (1/n) R^{2/3} S^{1/2}$ |
| | Energy dissipation at base of <i>Chute</i> or spillway | Use the Manning equation to determine the exit velocity, then design an appropriate Outlet Structure. |
| Slope Drain | Maximum water level upstream of the pipe inlet | Flow entry into a <i>Slope Drain</i> is usually governed by "inlet control" conditions. Refer to the design information on <i>Slope Drains</i> . |
| | Maximum flow velocity at outlet | It is usually sufficient to assume the pipe is flowing full at its outlet, thus: $V = Q/A$ |
| Temporary culvert crossings | Maximum flow rate through the culvert just prior to overtopping | It is usually sufficient to assume: $\Delta H = 1.7 (Q/A)^2/2g$ where: A = area of culvert |
| Sediment Basin low-flow, riser pipe outlet | Free surface water level within the riser pipe at peak discharge | Use the total head loss Equation A11 $\Delta H = H_e + H_f + H_{fittings} + H_{exit}$ |

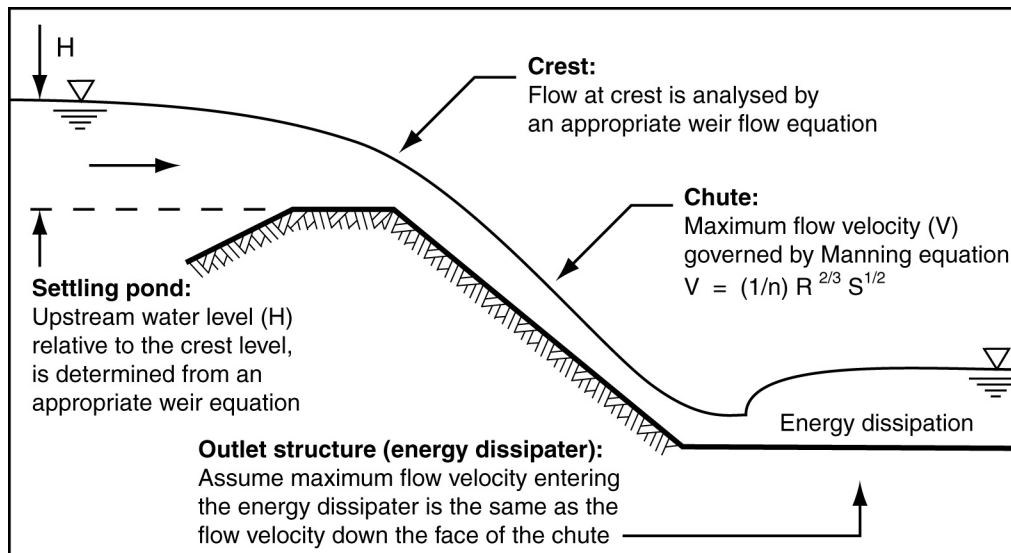

Figure A17 – Key design parameters for Chutes and spillways

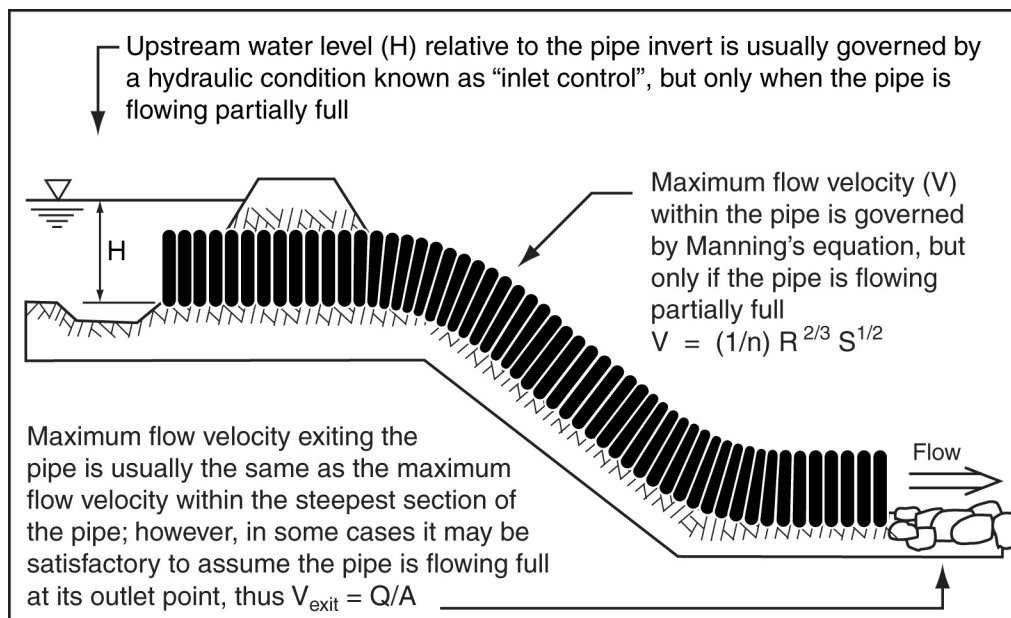

Figure A18 – Key design parameters for a Slope Drain

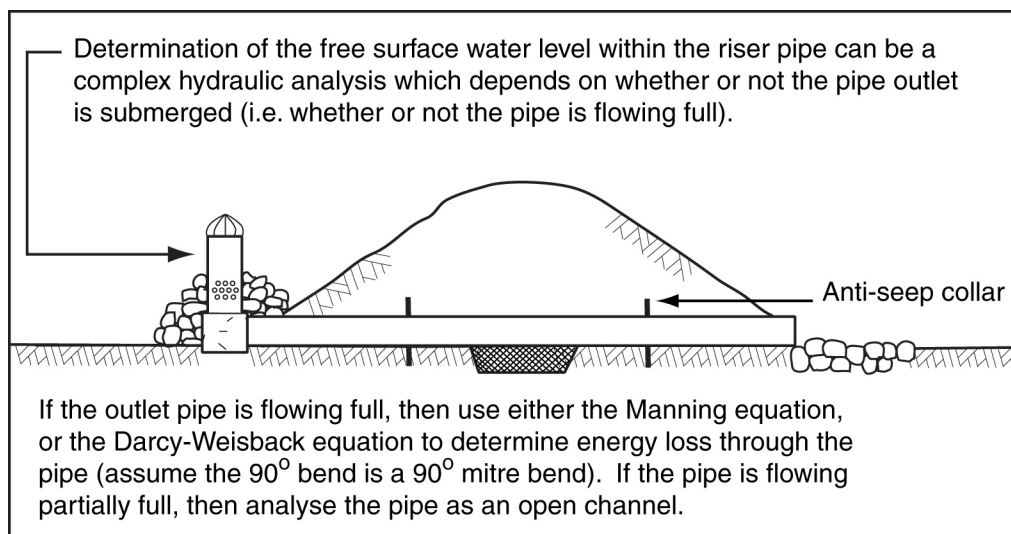

Figure A19 – Key design parameters for a Sediment Basin riser pipe outlet

Table A30a – Geometric properties of channels

| | |
|--|--|
| <p>Rectangular:</p>  | <p>Area (A):</p> $A = by$ <p>Wetted perimeter (P):</p> $P = b + 2y$ <p>Hydraulics radius (R):</p> $R = \frac{by}{(b + 2y)}$ |
| <p>Triangular (V-drain):</p>  | <p>Area (A):</p> $A = my^2$ <p>Wetted perimeter (P):</p> $P = 2y\sqrt{(1 + m^2)}$ <p>Hydraulics radius (R):</p> $R = \frac{my}{2\sqrt{(1 + m^2)}}$ |
| <p>Triangular (V-drain):</p>  | <p>Area (A):</p> $A = 0.5Ty$ <p>Wetted perimeter (P):</p> $P = \sqrt{T^2 + 4y^2}$ <p>Hydraulics radius (R):</p> $R = \frac{Ty}{2\sqrt{T^2 + 4y^2}}$ |
| <p>Asymmetric Triangular (V-drain):</p>  | <p>Area (A):</p> $A = \left(\frac{a+b}{2}\right)y^2$ <p>Wetted perimeter (P):</p> $P = y\left[\sqrt{(1+a^2)} + \sqrt{(1+b^2)}\right]$ <p>Hydraulics radius (R):</p> $R = \frac{0.5(a+b)y}{\sqrt{(1+a^2)} + \sqrt{(1+b^2)}}$ |

Table A30b – Geometric properties of channels

| | |
|---|--|
| <p>Trapezoidal:</p>  | <p>Area (A):</p> $A = y(b + my)$ <p>Wetted perimeter (P):</p> $P = b + 2y\sqrt{(1 + m^2)}$ <p>Hydraulics radius (R):</p> $R = \frac{y(b + my)}{b + 2y\sqrt{(1 + m^2)}}$ |
| <p>Trapezoidal:</p>  | <p>Area (A):</p> $A = 0.5y(T + b)$ <p>Wetted perimeter (P):</p> $P = b + \sqrt{4y^2 + (T - b)^2}$ <p>Hydraulics radius (R):</p> $R = \frac{y(T + b)}{2(b + \sqrt{4y^2 + (T - b)^2})}$ |
| <p>Circular:</p>  | <p>Area (A):</p> $A = \frac{D^2}{8}(\theta - \sin\theta)$ <p>Wetted perimeter (P):</p> $P = 0.5(D.\theta)$ <p>Hydraulics radius (R):</p> $R = \frac{D}{4}\left(1 - \frac{\sin\theta}{\theta}\right)$ <p>Top width (T):</p> $T = 2\sqrt{y(D - y)} = D.\sin\left(\frac{\theta}{2}\right)$ <p>where:</p> $\theta = 2\cos^{-1}\left(1 - \frac{2y}{D}\right)$ |
| <p>Parabolic:</p>  <p>Parabolic profile: $y = \text{constant}(T^2)$</p> | <p>Area (A):</p> $A = 0.67(T.y)$ <p>Wetted perimeter (P):</p> $P = T + \frac{8y^2}{3T}$ <p>Hydraulics radius (R):</p> $R = \frac{2T^2.y}{3T^2 + 8y^2}$ |

A7 Glossary of terms

| | |
|-----------------------------------|--|
| Average Recurrence Interval (ARI) | The average time period between exceedance of a given rainfall intensity or discharge. ARI is usually expressed as Y years. |
| ARR | Engineers Australia's publication Australian Rainfall and Runoff. |
| Catchment area (A) | The total area of land contributing stormwater runoff to the location under consideration. |
| Coefficient of runoff (C_Y) | A dimensionless coefficient used in the Rational Method for the calculation of the peak rate of storm runoff for a given design ARI. It may also be referred to as the discharge runoff coefficient. It is not the same as the Volumetric Runoff Coefficient. |
| Composite coefficient of runoff | A coefficient of runoff determined for a site of mixed ground conditions. |
| Critical storm duration | The duration of the design storm that produces the maximum peak discharge at a given location for a nominated storm frequency. It is usually assumed to be equal to the "time of concentration" of the catchment. |
| Depth of flow (y or h) | The vertical distance to the lowest point of a channel section from the free surface. The term "H" is often used instead of "h" for flow depth when the water has negligible flow velocity (i.e. when the velocity head ($V^2/2g$) is very small relative to flow depth). |
| Design discharge (QY) | Estimated peak discharge (m^3/s) for a given storm ARI (Y-years) used in the design of hydraulic structures. Thus, Q10 is the peak discharge of the 1 in 10 year design storm. |
| Design storm | A fictitious, isolated storm event of varying frequency and duration, used in the estimation of both design discharge and design flood hydrographs. Design storms are based on the statistical analysis of locally recorded rainfall data. They may be determined from the Engineers Australia's Australian Rainfall and Runoff (ARR) publication. |
| Flow area (A) | The cross-sectional area of flow normal to the direction of flow. |
| Fraction impervious | The proportion of a catchment that is effectively impervious to rainfall infiltration. It is expressed as a decimal or percentage. |
| Frequency factor (F_Y) | A factor that is multiplied by the coefficient of runoff for the 10 year ARI (C_{10}) to determine the coefficient of runoff (C_Y) for a selected design ARI for the location being considered (i.e. $C_Y = F_Y \cdot C_{10} \leq 1.0$). This factor is used in the ARR method for the determination of runoff. |
| Hydraulic mean depth (D_m) | The ratio of flow area to surface width ($D_m = A/B$). |
| Hydraulic radius (R) | The ratio of flow area to wetted perimeter ($R = A/P$). |

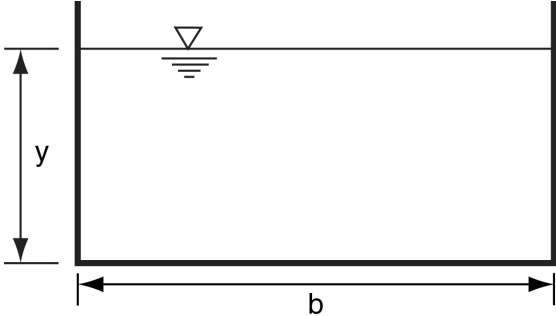
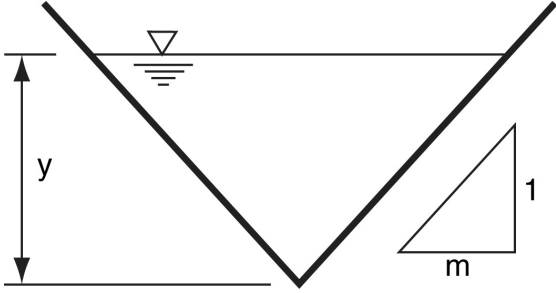
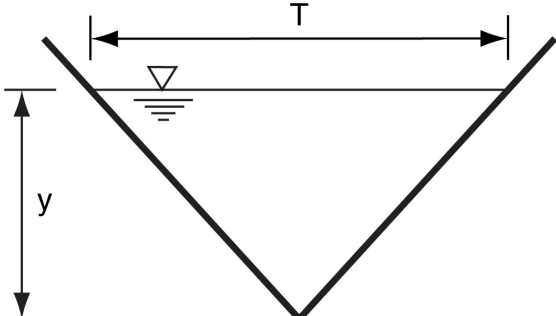
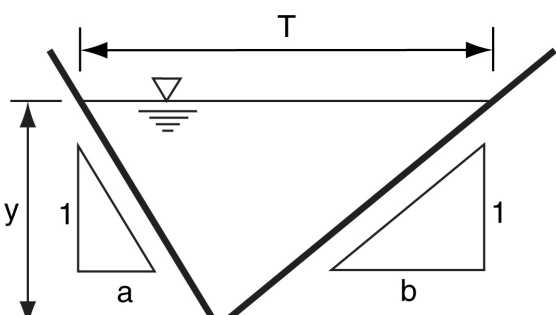
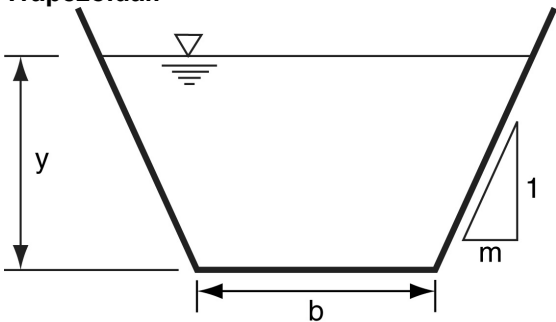
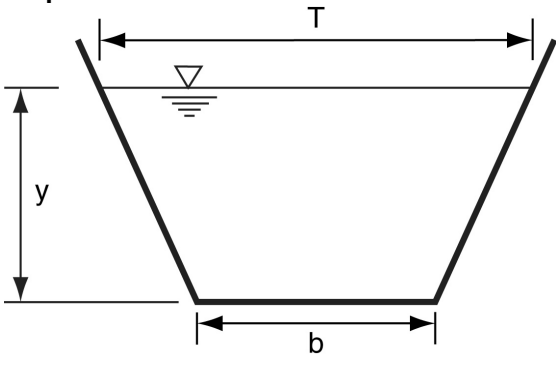
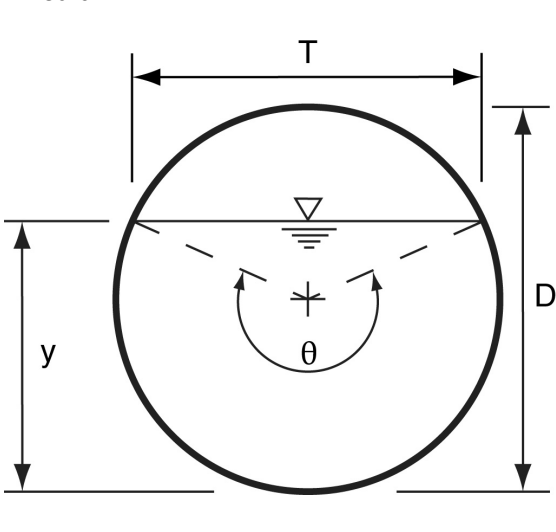
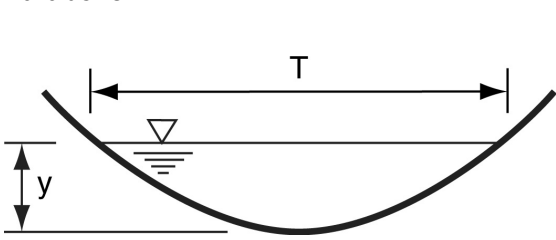
| | |
|--------------------------------------|---|
| Hydrograph | A plot or recording of stream discharge versus time. A flood hydrograph shows the rise and fall of the flood discharge at a given point along a stream. A design flood hydrograph represents the discharge from a theoretical design storm (usually determined from Australian Rainfall and Runoff). |
| Invert | The lowest portion of the internal surface of a drain or culvert at a given location or cross-section. |
| Isochrone | A line on a catchment joining points from which water has an equal time of travel to the outlet. |
| Intensity-Frequency-Duration (IFD) | Basic rainfall data used in hydrologic analysis as determined from the Australian Rainfall and Runoff (ARR) publication. The data consists of a set of curves relating the design rainfall intensity to its probable frequency for a given storm duration. These curves are unique for any given town or region. |
| Probable Maximum Flood (PMF) | The theoretically greatest runoff event from a particular drainage basin. |
| Probable Maximum Precipitation (PMP) | The theoretically greatest depth of precipitation for a given duration that is physically possible over a particular drainage basin. |
| QUDM | Queensland Urban Drainage Manual (NRW, 2007). |
| Rational Method | Common hydrology equation used to calculate the peak discharge (Q , m^3/s) expected from a given catchment surface condition (C) average storm intensity (I , mm/hr) and area (A , ha), where: $Q = CIA/360$ |
| Runoff | All water that drains from land and is collected in surface channels or waterways. Runoff is the water remaining from precipitation after the losses from evaporation, transpiration, surface storage and soil infiltration. |
| Stage (h) | The vertical distance of the free surface relative to an arbitrary datum. |
| Time of concentration (t_c) | Time required for storm runoff to flow from the most remote part of the catchment to the location on the site where the discharge is being determined. |
| Top surface width (B or T) | The width of the channel section at the free surface. |
| Velocity head ($V^2/2g$) | The kinetic energy of flowing water. |
| Wetted perimeter (P) | The length of the wetted surface measured normal to the direction of flow. |

A8 References

ANCOLD 2000a, *Guidelines on Selection of Acceptable Flood Capacity for Dams*. Australian National Committee on Large Dams Inc.

ANCOLD 2000b, *Guidelines on Assessment of the Consequences of Dam Failure*. Australian National Committee on Large Dams Inc.

ARR, 1977: Institution of Engineers, Australia 1977, *Australian Rainfall and Runoff: Flood Analysis and Design*, Canberra, A.C.T.

ARR, 1998: Institution of Engineers, Australia 1998, *Australian Rainfall and Runoff – A Guide to Flood Estimation*. Revised Edition, The Institution of Engineers, Australia, Barton, ACT. ISBN 085825 434 4.

Chow, V.T., 1959, *Open-Channel Flow*. McGraw-Hill Kogakusha, Ltd. Tokyo.

Fifield, J.S. 2001, *Designing for Effective Sediment and Erosion Control on Construction Sites*. Forester Communications, California. ISBN 0-9707687-0-2.

Landcom 2004, *Managing Urban Stormwater: Soils and Construction – Volume-1*, Landcom, New South Wales Government, ISBN 0-9752030-3-7.

Queensland Department of Natural Resources & Mines 2005, *Soil Conservation Measures – Design Manual for Queensland*. Queensland Government, Department of Natural Resources and Mines, Brisbane.

Queensland Department of Primary Industries 1992, *Soil Conservation Handbook. Part 9 – Design of Structures*. Revised edition, QDPI. Brisbane.

QUDM 2007, *Queensland Urban Drainage Manual*. Department of Natural Resources and Water, Brisbane, Queensland.

Soil Services 1998, *Construction Site Erosion and Sediment Control – Course Notes*. Soil Services and NSW Department of land and Water Conservation, Bathurst, NSW.

Witheridge, G.M. 2002, *Fish Passage Requirements at Waterway Crossings – Engineering Guidelines*. Catchments & Creeks Pty Ltd, Brisbane.

Appendix B

Sediment basin design and operation

This appendix provides guidance on the design and operation of Sediment Basins. Its function within this document is both educational and prescriptive.

Discussion within this appendix will be limited to the design of short-term Sediment Basins used during the construction phase of civil works. Guidelines on the design of sedimentation basins used as part of a long-term stormwater management strategy may be found within design guidelines for stormwater quality management, and Water Sensitive Urban Design.

B1 Introduction

A *Sediment Basin* is a purpose built dam designed to collect and settle sediment-laden water. It usually consists of a settling pond, a low-flow drainage or decant system, and a high-flow emergency spillway.

Sediment Basins generally perform two main functions: firstly the settlement of coarse-grained sediment particles (e.g. sand and coarse silt) from waters passing through the basin, and secondly the settlement of fine-grained particles (e.g. fine silt and clay) from waters retained within the basin following a storm event.

Even though the sizing of a *Sediment Basin* may be based on storm events of an average recurrence interval (ARI) of 3 months to 1 year, this does not mean the basin ceases to provide sediment trapping benefits during the larger, less frequent storms. Even when a basin is full of water, it can still be effective in the removal of coarse sediment from any flows passing through the basin.

It is the ability of *Sediment Basins* to reduce turbidity levels that allows these Type 1 sediment traps to significantly reduce the potential ecological harm caused by urban construction. To achieve this aim, *Sediment Basins* need be designed and operated in a manner that produces near-clear water discharge (i.e. total suspended solids concentrations not exceeding 50 mg/L), especially following periods of light rainfall.

Technical Note B1 – Protection of minor streams

The discharge of clear water from *Sediment Basins* following periods of light rainfall is important because it is during such rainfall conditions that many minor creek systems have insufficient base flow to flush-out and/or dilute any turbid water that may have entered the creek. This, however, does **not** imply that proper operation of *Sediment Basins* is not important during moderate to heavy rainfall. For further discussion refer to Principle 6.2 in Chapter 2.

This appendix outlines design procedures for three types of temporary *Sediment Basins*, Type C for coarse-grained soils, Type F for fine-grained soils, and Type D for dispersive soils.

The design of permanent sedimentation basins used within permanent stormwater treatment systems is not discussed within this appendix.

B2 Design Procedure

It is noted that the following design procedure may not address all relevant design issues on all sites. Prior to using this design procedure, advice should be sought from the relevant regulatory authority regarding any additional design requirements.

Design steps:

| Step | Action | Page |
|-------------|---|-------------|
| Step 1 | Assess the need for a <i>Sediment Basin</i> | B.4 |
| Step 2 | Select basin type | B.5 |
| Step 3 | Determine basin location | B.6 |
| Step 4 | Divert up-slope “clean” water | B.9 |
| Step 5a | Sizing Type C basins | B.10 |
| Step 5b | Sizing Type F/D basins | B.14 |
| Step 6 | Define the sediment storage volume | B.19 |
| Step 7 | Select internal and external bank gradients | B.20 |
| Step 8 | Design of flow control baffles | B.21 |
| Step 9 | Design the basin’s inflow system | B.26 |
| Step 10 | Design the primary outlet system | B.28 |
| Step 11 | Design the emergency spillway | B.35 |
| Step 12 | Assess the overall dimensions of the basin | B.37 |
| Step 13 | Locate maintenance access (de-silting) | B.39 |
| Step 14 | Define the sediment disposal method | B.39 |
| Step 15 | Assess the need for safety fencing | B.39 |
| Step 16 | Define the rehabilitation process for the basin area | B.40 |
| Step 17 | Define the basin’s operational procedures (flocculation etc.) | B.44 |

Summary of design requirements:

Table B1 – Summary of Sediment Basin design requirements

| Parameter | Type C basin | Type F & D basins |
|---|---|---|
| Soil characteristic (Step 2) | Less than 33% of soil finer than 0.02 mm and no more than 10% of soil dispersive. | Type F: More than 33% of soil finer than 0.02 mm. Type D: More than 10% of soil dispersive, or where turbidity control is essential. |
| Settling pond sizing (Step 5), surface area (A_s), or settling volume (V_s) | $A_s = 3400 H_e (Q)$ $Q = 0.5 \text{ times } 1 \text{ in } 1\text{yr flow}$ | $V_s = 10 R_{(Y\%, 5\text{-day})} C_v A$ |
| Length to width ratio (Step 5) | Hydraulic efficiency factor (H_e) is reduce with increasing length to width ratio | L:W of 3:1 is highly desirable |
| Minimum depth of settling zone (Step 5) | 0.6 m | 0.6 m |
| Sediment storage volume (Step 6) | 100% of settling volume | 50% of settling volume |
| Use of inlet chamber (Step 8) | Desirable if length to width ratio is less than 3:1, or if inflow is concentrated with high flow velocity. | |
| Internal baffles (Step 8) | Desirable if length to width ratio is less than 3:1 | |
| Use of outlet chamber (Step 8) | Essential if skimmer pipe outlet system is employed | Use depends on type of outlet system adopted |
| Control inflow conditions (Step 9) | Used to control erosion at inlets and, where practicable, ensure the inflow pipe invert is above the spillway crest elevation. | |
| Pre-treatment pond (Step 9) | Used to reduce the cost and frequency of de-silting operations. | |
| Primary outlet (Step 10) | Ensure choice of outlet system is compatible with basin type. | |
| Emergency spillway minimum design capacity (Step 11) | Less and 3 month design life: capacity of 1 in 10 year ARI. 3 to 12 months design life: capacity of 1 in 20 year ARI. Greater than 12 months design life: capacity of 1 in 50 yr ARI. | |
| Elevation from top of riser pipe outlet to spillway crest | 300 mm (min) | N/A |
| Freeboard from maximum pond water level to top of virgin soil bank (Step 11) | 150 mm (min) | 150 mm (min) |
| Freeboard from maximum pond water level to top of fill embankment (Step 11) | 300 mm (min) | 300 mm (min) |
| Minimum freeboard along spillway chute (Step 11) | 300 mm (min) | 300 mm (min) |
| Minimum embankment crest width (Step 12) | 2.5 m | 2.5 m |
| Maximum gradient of access ramp (Step 13) | 6:1 | 6:1 |
| Chemical flocculation (Step 17) | As required to satisfy water quality objectives. | Type F: As required to satisfy water quality objectives. Essential for Type D basins. |

Step 1 Assess the need for a *Sediment Basin*

A *Sediment Basin* is normally a Type 1 sediment trap that is usually required when the estimated soil erosion rates or hazard rating exceeds a nominal value. *Sediment Basins* may also be required when the disturbed soils are dispersive, or there is a specific need to control runoff turbidity, or achieve a specified discharge water quality.

As a general rule, the further upstream a soil disturbance is within a major coastal drainage catchment, the greater the need for turbidity control due to the greater total reach length over which this turbidity may cause environmental harm.

The recommended application of Type 1 sediment traps (i.e. *Sediment Basins*) is presented in Section 4.5.1 of Chapter 4 – *Design standards and technique selection*. Table 4.5.1 recommends the use of Type 1 sediment traps within sub-catchments with a catchment area exceeding 2500 m² and an estimated soil loss rate that exceeds the equivalent of 150 t/ha/yr.

Step 2 Select basin type

Selection of the type of *Sediment Basin* is governed by the site's soil properties as outlined in Table B2.

Table B2 – Selection of basin type

| Soil and/or catchment conditions ^[1] | Basin type |
|--|--------------|
| Less than 33% of soil finer than 0.02 mm (i.e. $d_{33} > 0.02$ mm) and no more than 10% of soil dispersive. ^[2] | Type C basin |
| More than 33% of soil finer than 0.02 mm (i.e. $d_{33} < 0.02$ mm) and no more than 10% of soil dispersive. ^[2] | Type F basin |
| More than 10% of soil dispersive ^[2] , or when a Stormwater Management Plan (SMP), or adopted Water Quality Objectives (WQOs) specify strict controls on turbidity levels and/or suspended solids concentrations for discharged waters. | Type D basin |

Notes:

- [1] If more than one soil type exists on the site, then the most stringent criterion applies (i.e. Type D supersedes Type F, which itself supersedes Type C).
- [2] The percentage of soil that is dispersive is measured as the combined decimal fraction of clay (<0.002 mm) plus half the percentage of silt (0.002–0.02 mm), multiplied by the dispersion percentage (refer to Appendix G – *Soils and revegetation*).

Discussion:

The three types of basins are described below:

Type C basin: These basins are mostly suitable for coarse grained, good settling soils (defined as Type C soils). Type C basins may be operated as either “dry” or “wet” basins (refer to Step 5) depending on the requirement for stormwater reuse on the site. The critical design parameter in a Type C basin is the effective surface area of the settling pond.

Type F basin: These basins are generally suitable for fine grained soils that can readily settle without the need for flocculating agents (defined as Type F soils). Type F basins can only be operated as wet basins (Step 5). The critical design parameter for a Type F basin is the volume of the settling pond.

Type D basin: These basins are required for the treatment of dispersive soils that do not readily settle without the use of flocculating agents (defined as Type D soils). Type D basins can only be operated as wet basins (Step 5). The critical design parameter for a Type D basin is the volume of the settling pond.

Note: even if soil conditions satisfy the requirements for a Type C basin, this does not guarantee that the water quality achieved by the basin will satisfy the required environmental objectives. As such, a poorly performing Type C basin may need to be operated in accordance with the procedures defined for a Type F or Type D basin in order to satisfy specified water quality objectives. Similarly, Type F basins may need to be chemically treated (i.e. as per Type D basins) if they fail to achieve the specified water quality objectives.

Step 3 Determine basin location

All reasonable and practicable measures must be taken to locate *Sediment Basins* within a work site so as to maximise their overall sediment trapping efficiency. Issues that need to be given appropriate consideration include:

- (i) Locate all basins within the relevant property boundary.
- (ii) Locate all basins to maximise the collection of sediment-laden runoff generated from within the site throughout the construction period and up until the site is adequately stabilised against erosion.
- (iii) Do not locate a *Sediment Basin* within a waterway, or major drainage channel, unless it can be demonstrated that:
 - the basin will be able to achieve its design requirements, i.e. the specified treatment standard (water quality objective);
 - settled sediment will not be resuspended and washed from the basin during stream flows equal to, or less than, the 1 in 5 year ARI;
 - the basin and emergency spillway will be structurally sound during the design storm specified for the sizing of the emergency spillway.
- (iv) Where practical, locate *Sediment Basins* above the 1 in 5 year ARI flood level. Where this is not practical, then all reasonable efforts should be taken to maximise the flood immunity of the basin.
- (v) Avoid locating a basin in an area where adjacent construction works may limit the operational life of the basin.
- (vi) Ensure basins have suitable access for maintenance and de-silting.

If a *Sediment Basin* is to be retained as a permanent land feature, such as parkland or a stormwater detention/retention system, then the location of the basin may in part be governed by the requirements of this final land feature. However, if the desired location of this permanent land feature means that the basin will be ineffective in the collection and treatment of sediment-laden runoff, then an alternative basin location will be required.

Discussion:

Discussion on the location of *Sediment Basins* and other sediment traps adjacent to waterways is presented in Appendix I – *Instream works*.

It is not always necessary to have just one *Sediment Basin*. In some locations it may be highly desirable to divide the work site into smaller, manageable, sub-catchments and to place a separate basin within each sub-catchment.

Generally speaking, it is undesirable to divide a basin into a series of two or more in-line basins (i.e. basins operating in *series* rather than in *parallel*). A number of small basins operating in series can have significantly less sediment trapping efficiency than a single basin, even though the series of smaller basins may have the same total surface area or volume. This is because of the remixing that can occur when flow from one basin is transported through a pipe or pipes into the next basin. However, there are exceptions to this rule, such as in the following cases:

- (i) Type F & D *Sediment Basins* where at least one of the basins has sufficient surface area and length to width ratio to satisfy the requirements of a Type C

basin (Figure B2). The combined *settling volume* of the basins must not be less than that specified for a Type F or Type D basin.

- (ii) A series of basins where each settling pond is connected by several pipes or culverts evenly spaced across the full width of the basin (Figure B3). Such a design must minimise the effects of inflow jetting from each pipe/culvert and allow an even distribution of flow across the full basin width. In such cases the minor sediment remixing that occurs as flow passes through the interconnecting pipes/culverts is usually compensated for by the improved hydraulic efficiency of the overall basin surface area.

In case (ii) above, the flow velocity through the interconnecting pipes/culverts should not exceed the relevant sediment re-suspension velocity specified in Step 8.

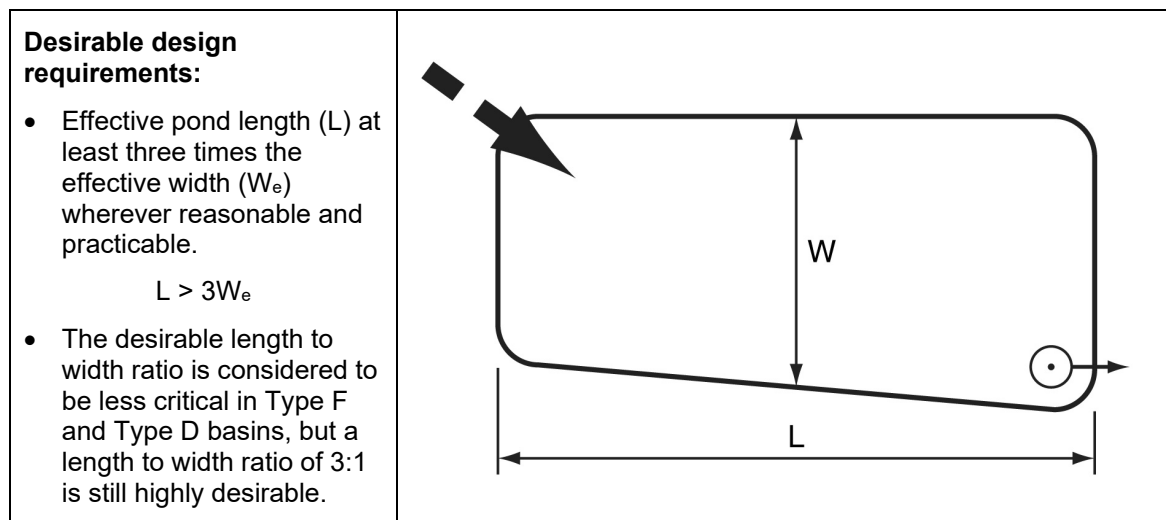

Figure B1 – Single Sediment Basin

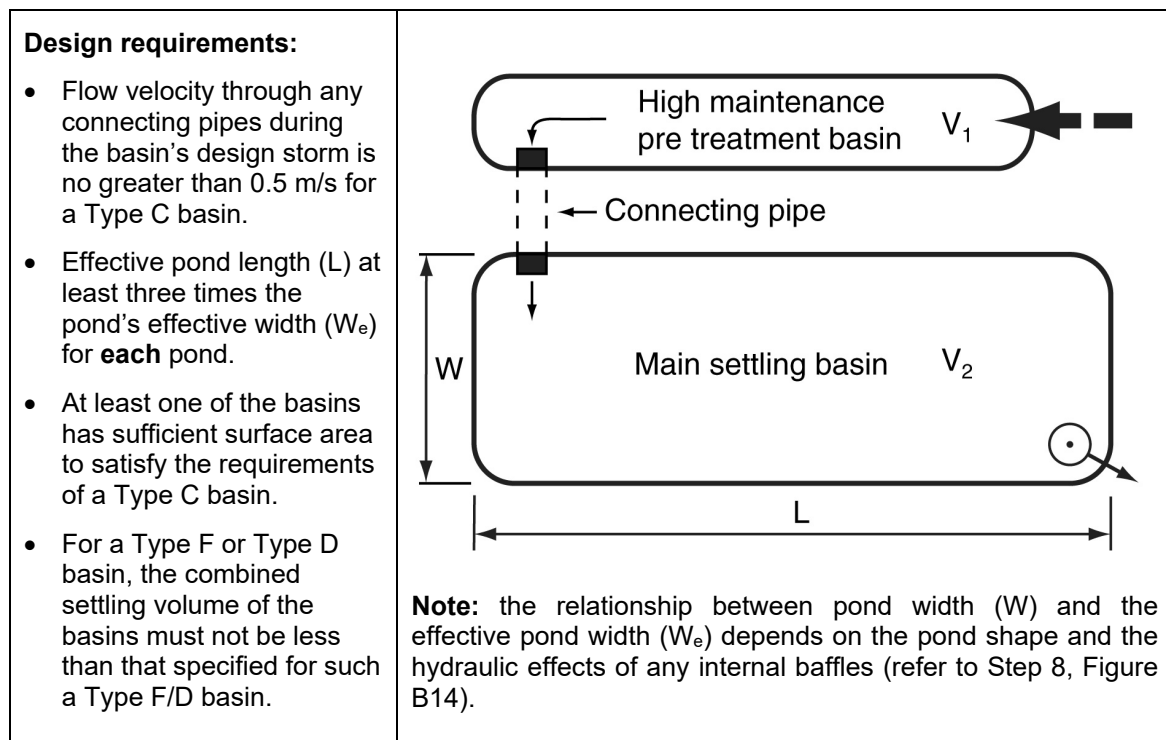

Figure B2 – Multiple Sediment Basins with single connecting pipe/culvert

The double basin shown in Figure B2 makes use of a narrow (say less than 5 m width) pre-treatment basin that can be de-silted on a regular basis at low cost. The main settling pond has a surface area equivalent to a Type C basin independent of whether the basin is operated as a Type D, F or D basin. If a Type F/D basin is required, then the combined settling volumes ($V_1 + V_2$) must satisfy that required for a Type F/D basin.

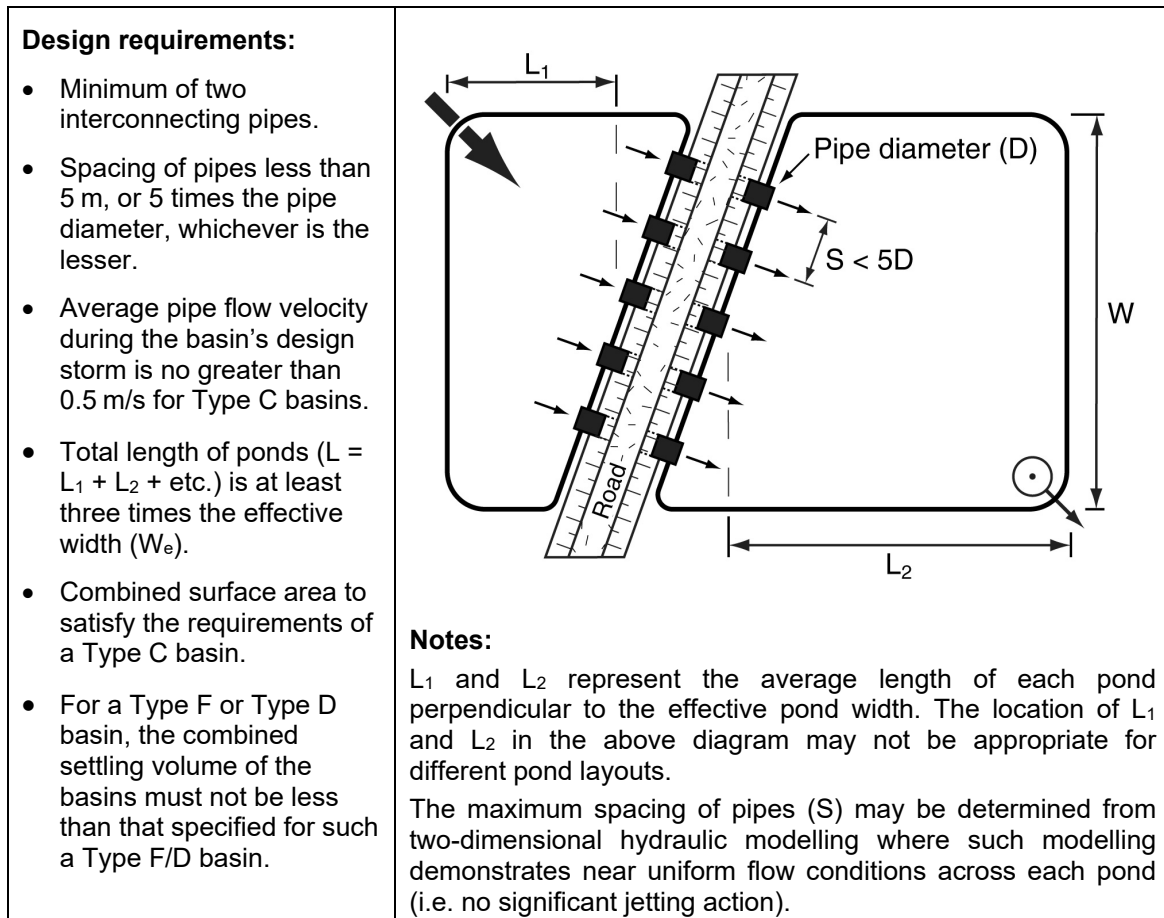

Figure B3 – Multiple Sediment Basins with multiple connecting pipes

Step 4 Divert up-slope “clean” water

Wherever reasonable and practicable, up-slope “clean” water should be diverted around the *Sediment Basin* to decrease the size and cost of the basin and increase its efficiency. The adopted flow diversion systems may need to be modified for each stage of construction as new areas of land are first disturbed, then stabilised.

“Clean” water is defined as water that has not been contaminated within the property, or by activities directly associated with the construction/building works.

The intent is to minimise the volume of uncontaminated water flowing to a basin at any given time during the operation of the basin.

Discussion:

One of the primary goals of an effective erosion and sediment control program is to divert external run-on water and any uncontaminated site water around major sediment traps such as a *Sediment Basin* as demonstrated in Figure B4.

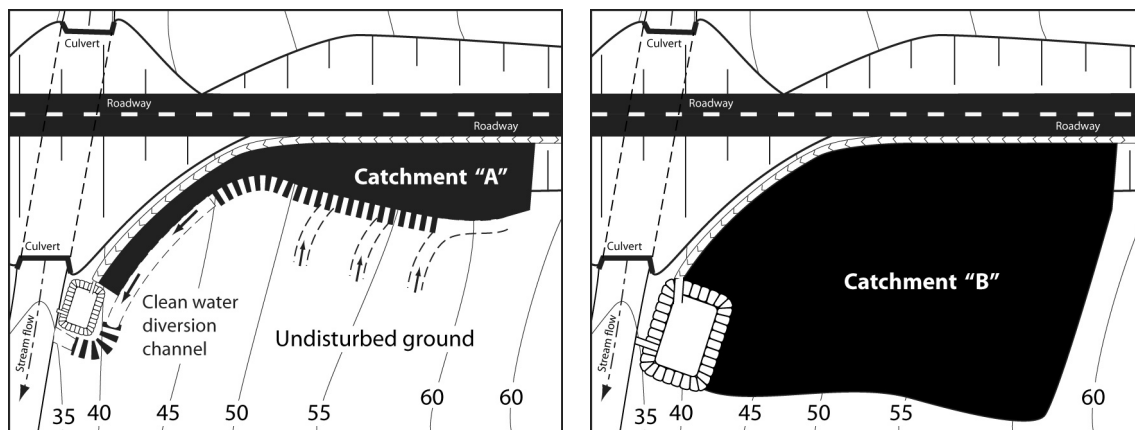

(a) Up-slope “clean” water diverted around the *Sediment Basin*

(b) Up-slope “clean” water not diverted around the *Sediment Basin*

Figure B4 – Beneficial effects of diverting “clean” water around a basin

The effective catchment area may vary significantly during the construction phase as areas of disturbance are first connected to a *Sediment Basin*, then taken off-line as site rehabilitation occurs. It is considered best practice to prepare a Construction Drainage Plan (CDP) for each stage of construction.

Step 5a Sizing Type C basins

The settling pond within a Type C *Sediment Basin* is divided (horizontally) into two zones: the upper *settling zone* and the lower *sediment storage zone* as shown in Figure B5.

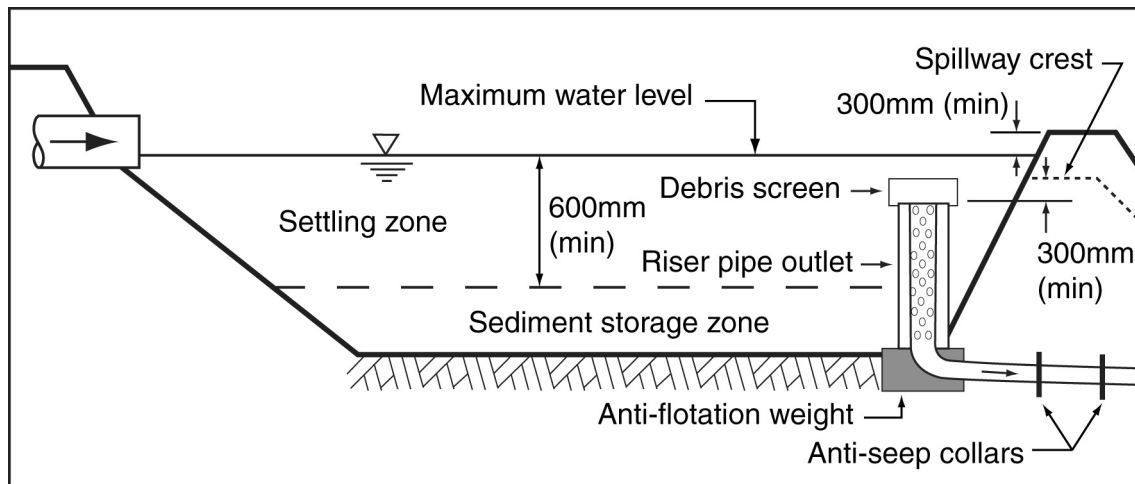

Figure B5 – Type C Sediment Basin with riser pipe outlet (long section)

The minimum volume of the upper settling zone is defined by Equation B1.

$$A_s = 3400 H_e (Q) \quad (B1)$$

where: A_s = Surface area of settling pond at the base of the settling zone [m²]
 H_e = Hydraulic efficiency correction factor
 Q = design flow rate [m³/s]

Unless otherwise required by a regulatory authority, the design flow rate (Q) for a Type C *Sediment Basin* must be 0.5 times the peak discharge for the 1 in 1 year ARI storm.

The minimum recommended depth of the “settling zone” is 0.6 m, or $L/200$ for basins longer than 120 m (where L = effective basin length). Settling zone depths greater than 1 m should be avoided if settlement velocities are expected to be slow.

The desirable minimum length to width ratio of 3:1, otherwise internal baffles need to be used wherever practicable to prevent short-circuiting of flows. Step 8 provides guidelines on the use of internal baffles.

The hydraulic efficiency correction factor (H_e) depends on flow conditions entering the basin and the shape of the settling pond. Table B3 provides recommended values of the hydraulic efficiency correction factor.

Where available space does not permit construction of the ideal *Sediment Basin*, then a smaller basin may be used; however, erosion control and site rehabilitation standards must be appropriately increased to a higher standard to compensate.

A Type C *Sediment Basin* that is less than the ideal size must be considered either a Type 2 or Type 3 sediment trap based on the effective particle settlement capabilities.

Table B3 – Hydraulic efficiency correction factor (H_e)

| Flow condition within basin | Effective ^[1] length:width | H_e |
|---|---------------------------------------|-------|
| Uniform or near-uniform flow conditions across the full width of basin. ^[2] For basins with concentrated inflow, uniform flow conditions may be achieved through the use of an appropriate inlet chamber arrangement (refer to Step 8). | 1:1 | 1.2 |
| | 3:1 | 1.0 |
| Concentrated inflow (piped or overland flow) primarily at one inflow point and no inlet chamber to evenly distribute flow across the full width of the basin. | 1:1 | 1.5 |
| | 3:1 | 1.2 |
| | 6:1 | 1.1 |
| | 10:1 | 1.0 |
| Concentrated inflow with two or more separate inflow points and no inlet chamber to evenly distribute flow across the full width of the basin. | 1:1 | 1.2 |
| | 3:1 | 1.1 |

Notes:

- [1] The effective length to width ratio for *Sediment Basins* with internal baffles (Step 8, Figure B14) is measured along the centreline of the dominant flow path.
- [2] Uniform flow conditions may also be achieved in a variety of ways including through the use of an inlet chamber and internal flow control baffles (refer to Step 8).

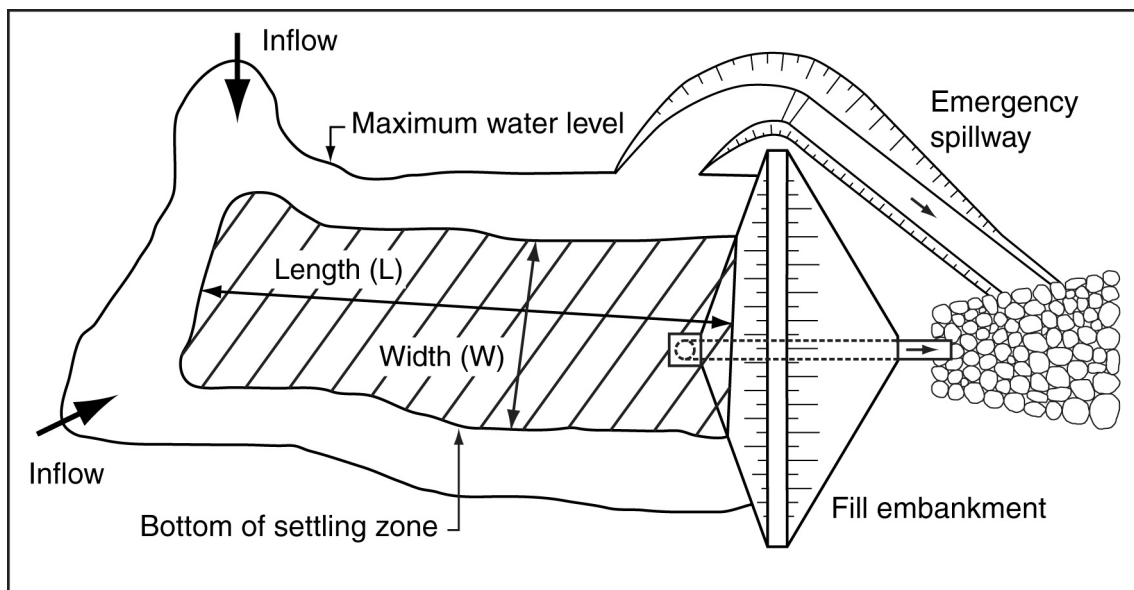
**Figure B6 – Type C Sediment Basin with riser pipe outlet (plan view)**

Unlike permanent stormwater treatment ponds and wetlands, Type C basins are not designed to allow high flows to bypass the basin. Even when the basin is full, sediment-laden stormwater runoff continues to be directed through the basin (Figure B6). This allows the continued settlement of coarse-grained particles contained in the flow. Such basin management practices may result in the re-suspension and discharge of some previously settled fine sediments during heavy storms, but the task of trapping the anticipated large volume of sand and coarse silts washed from a construction site is considered more important.

Discussion:

Equation B1 (reproduced below as Equation B2) is the standard equation used in the sizing of Type C Sediment Basins.

$$A_s = 3400 \cdot H_e (Q) \quad (B2)$$

This equation is based on the following assumptions:

- Critical particle size of 0.02 mm
- Sediment specific gravity of 2.65
- Water temperature of 13° C (assumed to be the temperature of rainfall)
- Flat bed basin
- The application of Stokes' Law

If near-uniform flow conditions occur throughout the basin (i.e. 100% hydraulically efficient basin with no inflow jetting issues or dead water pockets) then the hydraulic efficiency correction factor (H_e) equals unity and the equation reduces to Equation B3.

$$A_s = 3400 (Q) \quad (B3)$$

If local soil properties and/or hydraulic conditions are significantly different from the above, then the basin should be sized using first principles as presented in Technical Note B2.

The choice of critical particle size will depend on:

- particle size distribution
- design storm flow rate (Q)
- sediment flow rate during the design storm
- specific gravity of the sediment

As a general design rule, the critical particle size is set to a value of 0.02 mm; alternatively, the critical particle size may be set equal to the grain size of which 70% of the sediment is larger (i.e. d_{30}).

Technical Note B2 – Derivation of Type C basin sizing formula

Consider a rectangular *Sediment Basin* with uniform inflow (Q), width (W), depth (D) and length (L):

- the average forward velocity: $V_H = Q/(D.W)$
- the travel time across the basin: $t_H = L/(V_H)$
- thus, $t_H = (L.D.W)/Q = \text{Volume/Discharge}$
- in other words, $t_H = \text{retention time}$

Note: the assumption of “uniform flow” mean that the hydraulic efficiency correction factor, $H_e = 1.0$.

Now it is assumed that the falling velocity of a sediment particle may be estimated using Stokes' Law. Thus the falling velocity depends on:

- particle size, shape and relative density
- water temperature (a factor of viscosity) assumed to be based on temperature of rainfall
- water motion (turbulence and up-flow caused by mass settlement of sediment particles)
- electro-magnetic forces (particle dispersion)

Stokes' Law is presented as:

$$V_p = (g.(s-1).d^2)/(18.\mu) \quad (B4)$$

where: V_p = particle falling velocity [m/s]

s = specific gravity of particle

g = acceleration due to gravity [m/s^2]

d = particle diameter [m]

μ = kinematic viscosity of the water at a given temperature [m^2/s^2]

For a specific gravity of 2.65, particle settling velocities are presented in Table B9:

Table B9 – Particle settling velocity (mm/s) for different water temperatures

| Diameter (mm) | 10° C | 15° C | 20° C |
|---------------|-------|-------|-------|
| 0.01 | 0.07 | 0.08 | 0.09 |
| 0.02 | 0.27 | 0.31 | 0.35 |
| 0.05 | 1.67 | 1.91 | 2.17 |
| 0.10 | 6.67 | 7.65 | 8.69 |

If the *Sediment Basin* is sized such that the critical particle size settles to the bed (t_p) just before reaching the end of the basin, then:

$$t_H = t_p$$

or

$$t_H = (L.D.W.)/Q = D/V_p$$

thus

$$\text{Surface Area } (A_s) = L.W = Q/V_p$$

So for a soil with critical particle size of 0.02 mm, and specific gravity of 2.65, and with a basin water temperature of 13° C, then $V_p = 0.000294$ m/s, thus:

$$A_s = Q/0.000294$$

or

$$A_s = 3400(Q) \quad (B5)$$

where: A_s = surface area of *Sediment Basin* at the base of the settling zone

Q = design storm peak flow rate; typically $Q = 0.5 Q_1$

Q_1 = peak discharge from the 1 in 1 year ARI design storm

If near-uniform flow conditions do not occur throughout the basin, then the required surface area (A_s) is determined from Equation B6.

$$A_s = 3400 \cdot H_e (Q) \quad (B6)$$

Step 5b Sizing Type F/D basins

The settling pond within a Type F or Type D *Sediment Basin* is divided (horizontally) into two zones: the upper *settling zone* and the lower *sediment storage zone* as shown in Figure B7.

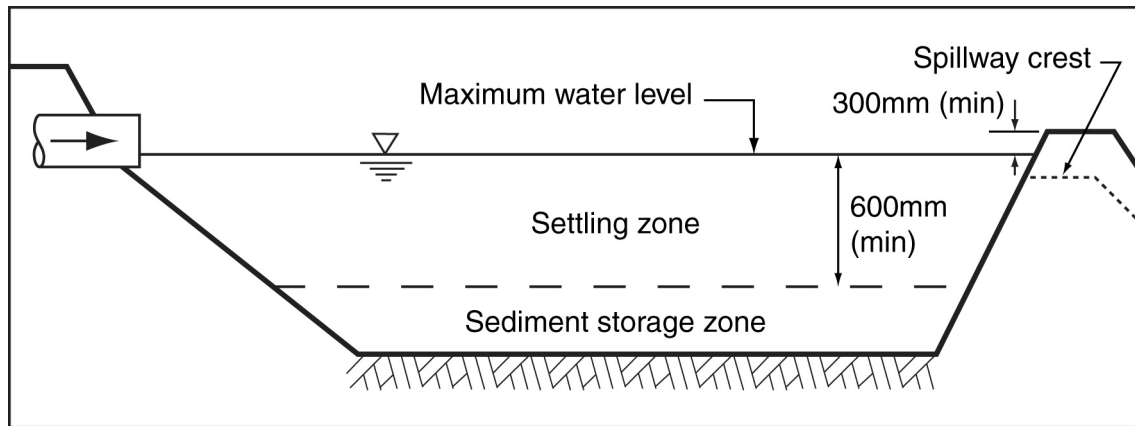

Figure B7 – Settling zone and sediment storage zone

The minimum volume of the upper settling zone is defined by Equation B7.

$$V_s = 10 \cdot R_{(Y\%,5\text{-day})} \cdot C_v \cdot A \quad (\text{B7})$$

where: V_s = volume of the settling zone [m³]

$R_{(Y\%,5\text{-day})}$ = Y%, 5-day rainfall depth [mm]

C_v = volumetric runoff coefficient (refer to Table B7)

A = effective catchment surface area connected to the basin [ha]

The minimum recommended depth of the “settling zone” is 0.6 m, or L/200 for basins longer than 120 m (where L = effective basin length). Settling zone depths greater than 1m should be avoided if settlement velocities are expected to be slow.

The desirable minimum length to width ratio of 3:1 is recommended for Type F and Type D basins. The length to width ratio is important for Type F and Type D basins because they operate as continuous-flow settling ponds (as per Type C basins) once flow begins to discharge over the emergency spillway. Step 8 provides guidelines on the use of internal baffles.

Equation B8 and Tables B5 and B6 provide preliminary $R_{(Y\%,5\text{-day})}$ values for various locations. Both Equation B8 and Tables B5 and B6 have been determined by developing a simple correlation between $R_{(Y\%,5\text{-day})}$ and the average 1 in 1 year, 120 hour (5-day) rainfall intensity based on the data obtained from Landcom (2004). It is highly recommended that actual $R_{(Y\%,5\text{-day})}$ values be determined for each region based on analysis of local rainfall records wherever practicable.

$$R_{(Y\%,5\text{-day})} = K_1 \cdot I_{(1\text{yr}, 120\text{hr})} + K_2 \quad (\text{B8})$$

where: K_1 = Constant (Table B4)

K_2 = Constant (Table B4)

$I_{(1\text{yr}, 120\text{hr})}$ = Average rainfall intensity for a 1 in 1 year ARI, 120 hr storm [mm/hr]

Recommendation on the choice of Y% and the respective K_1 and K_2 constant are provided in Table B4.

Table B4 – Recommended equation constants

| Recommended application | Y% | K_1 | K_2 |
|---|-----|-------|-------|
| Basins with design life less than 6 months | 75% | 12.9 | 9.9 |
| Basins with a design life greater than 6 months | 80% | 17.0 | 11.2 |
| Basins discharging to sensitive receiving waters. | 85% | 23.2 | 12.6 |
| At the discretion of the regulatory authority | 90% | 33.5 | 14.2 |
| At the discretion of the regulatory authority | 95% | 56.7 | 14.6 |

Where available space does not permit construction of the ideal *Sediment Basin*, then a smaller basin may be used; however, erosion control and site rehabilitation standards must be appropriately increased to a higher standard to compensate.

A Type F/D basin that is less than the ideal size must be considered either a Type 2 or Type 3 sediment trap based on the effective sediment trapping capabilities.

Type F and D basins are typically designed for a maximum 5-day cycle—that being the filling, treatment and discharge of the basin within a maximum 5-day period. In some tropical regions this may not be practical, and either a shorter or longer time frame may be required. The use of a shorter time period usually requires application of fast acting flocculants that may require a much higher degree of environmental management compared to gypsum. The use of a longer time period will require the construction of a significantly larger basin.

Unlike permanent stormwater treatment ponds and wetlands, Type F and D basins are not designed to allow high flows to bypass the basin. Even when the basin is full, sediment-laden stormwater runoff continues to be directed through the basin. This allows the continued settlement of coarse-grained particles contained in the flow. Such basin management practices may allow some re-suspension and discharge of previously settled fine sediments during heavy storms, but the task of trapping the anticipated large volume of sand and coarse silts washed from a construction site is considered more important.

In effect, Type F and D basins are designed to produce high quality outflows during the more frequent light storms (i.e. storms less than the 1 in 1 year ARI storm), but to also allow the continued trapping of coarse sediment during the less frequent heavy storms (i.e. storms equal to, or greater than, the 1 in 1 year ARI storm).

It is noted that the volumetric runoff coefficient (C_v) is **not** the same as the discharge runoff coefficient (C) used in the Rational Method to calculate peak runoff discharges. Refer to Appendix A for further discussion on construction site hydrology.

Typical values of the volumetric runoff coefficient are presented in Table B7 based on the soil groups presented in Section A3.1, Appendix A – *Construction site hydrology and hydraulics*. For impervious surfaces a volumetric runoff coefficient of 1.0 is adopted.

Table B5 – Queensland 1 year, 5-day rainfall intensity, and default values for 75%, 80%, 85% & 90% 5-day rainfall depth

| Location (North to South) | South | East | Intensity (mm/hr) (1yr, 120hr) | Default 5-Day Rainfall depth "R" (mm) | | | |
|------------------------------|---------------|----------------|--------------------------------------|---------------------------------------|-------------|-------------|-------------|
| | | | | 75th% | 80th% | 85th% | 90th% |
| Weipa | 12.657 | 141.909 | 1.45 | 28.7 | 35.8 | 46.2 | 62.7 |
| Cairns | 16.917 | 145.767 | 2.65 | 44.2 | 56.2 | 74.1 | 103 |
| Mareeba | 17.000 | 145.433 | 1.34 | 27.2 | 33.9 | 43.7 | 59.0 |
| Innisfail | 17.533 | 146.017 | 3.50 | 55.2 | 70.6 | 93.8 | 131 |
| Blunder Creek | 17.733 | 145.433 | 1.39 | 27.9 | 34.8 | 44.8 | 60.7 |
| Nitchaga Creek | 17.733 | 145.617 | 2.72 | 45.1 | 57.4 | 75.7 | 105 |
| Ingham | 18.650 | 146.167 | 2.74 | 45.4 | 57.7 | 76.1 | 106 |
| Blueswater Creek | 19.167 | 146.533 | 2.08 | 36.8 | 46.5 | 60.8 | 83.8 |
| Townsville | 19.267 | 146.817 | 1.92 | 34.7 | 43.8 | 57.1 | 78.4 |
| Ayr | 19.567 | 147.400 | 1.63 | 31.0 | 38.9 | 50.4 | 68.7 |
| Bowen | 20.017 | 148.250 | 1.73 | 32.3 | 40.6 | 52.7 | 72.1 |
| Charters Towers | 20.083 | 146.267 | 0.85 | 20.9 | 25.6 | 32.3 | 42.6 |
| Mt Isa | 20.733 | 139.483 | 0.74 | 19.5 | 23.8 | 29.8 | 39.0 |
| Mary Kathleen | 20.783 | 139.983 | 0.77 | 19.9 | 24.3 | 30.5 | 40.0 |
| Mackay | 21.150 | 149.183 | 1.92 | 34.7 | 43.8 | 57.1 | 78.4 |
| Winton | 22.383 | 143.033 | 0.68 | 18.7 | 22.7 | 28.4 | 36.9 |
| Yeppoon | 23.133 | 150.733 | 1.64 | 31.1 | 39.0 | 50.6 | 69.1 |
| Rockhampton | 23.367 | 150.533 | 1.24 | 25.9 | 32.2 | 41.4 | 55.7 |
| Longreach | 23.450 | 144.250 | 0.70 | 19.0 | 23.1 | 28.8 | 37.6 |
| Emerald | 23.517 | 148.167 | 0.86 | 21.0 | 25.8 | 32.5 | 43.0 |
| Blackwater | 23.583 | 148.883 | 0.83 | 20.6 | 25.3 | 31.8 | 42.0 |
| Gladstone | 23.85 | 151.267 | 1.27 | 26.3 | 32.8 | 42.1 | 56.7 |
| Biloela | 24.400 | 150.517 | 0.82 | 20.5 | 25.1 | 31.6 | 41.6 |
| Moura | 24.567 | 149.983 | 0.80 | 20.3 | 24.8 | 31.2 | 41.0 |
| Bundaberg | 24.867 | 152.350 | 1.18 | 25.2 | 31.2 | 40.0 | 53.7 |
| Maryborough | 25.533 | 152.700 | 1.38 | 27.8 | 34.6 | 44.6 | 60.4 |
| Gayndah | 25.617 | 151.617 | 0.76 | 19.7 | 24.1 | 30.2 | 39.6 |
| Gympie | 26.183 | 152.667 | 1.38 | 27.8 | 34.6 | 44.6 | 60.4 |
| Charleville | 26.400 | 146.250 | 0.60 | 17.7 | 21.4 | 26.5 | 34.3 |
| Kingaroy | 26.533 | 151.833 | 0.73 | 19.3 | 23.6 | 29.5 | 38.6 |
| Roma | 26.583 | 148.783 | 0.62 | 17.9 | 21.7 | 27.0 | 34.9 |
| Nambour | 26.633 | 152.967 | 1.88 | 34.2 | 43.1 | 56.2 | 77.1 |
| Maroochydore | 26.650 | 153.100 | 1.79 | 33.1 | 41.6 | 54.1 | 74.1 |
| Chinchilla | 26.733 | 150.633 | 0.65 | 18.3 | 22.2 | 27.7 | 35.9 |
| Mooloolah River | 26.750 | 152.967 | 1.96 | 35.3 | 44.5 | 58.1 | 79.8 |
| Caloundra | 26.800 | 153.133 | 1.73 | 32.3 | 40.6 | 52.7 | 72.1 |
| Caboolture | 27.083 | 152.950 | 1.46 | 28.8 | 36.0 | 46.5 | 63.0 |
| Dalby | 27.183 | 151.250 | 0.59 | 17.5 | 21.2 | 26.3 | 33.9 |
| South Pine River | 27.333 | 152.917 | 1.45 | 28.7 | 35.8 | 46.2 | 62.7 |
| Samford | 27.367 | 152.883 | 1.41 | 28.1 | 35.1 | 45.3 | 61.4 |
| Brisbane | 27.467 | 153.017 | 1.34 | 27.2 | 33.9 | 43.7 | 59.0 |
| Bulimba | 27.533 | 153.133 | 1.54 | 29.8 | 37.3 | 48.3 | 65.7 |
| Toowoomba | 27.567 | 151.950 | 0.86 | 21.0 | 25.8 | 32.5 | 43.0 |
| Ipswich | 27.617 | 152.783 | 0.94 | 22.1 | 27.2 | 34.4 | 45.6 |
| Beenleigh | 27.717 | 153.200 | 1.56 | 30.1 | 37.7 | 48.8 | 66.4 |
| Southport | 27.967 | 153.417 | 1.68 | 31.6 | 39.7 | 51.6 | 70.4 |
| Beaudesert | 27.983 | 153.000 | 0.96 | 22.3 | 27.5 | 34.9 | 46.3 |
| Canungra | 27.983 | 153.150 | 1.68 | 31.6 | 39.7 | 51.6 | 70.4 |
| Boonah | 28.000 | 152.683 | 0.87 | 21.2 | 26.0 | 32.8 | 43.3 |
| Nerang River | 28.000 | 153.300 | 1.70 | 31.9 | 40.0 | 52.0 | 71.1 |
| St George | 28.050 | 148.583 | 0.61 | 17.8 | 21.6 | 26.7 | 34.6 |
| Back Creek | 28.117 | 153.183 | 1.84 | 33.7 | 42.4 | 55.3 | 75.7 |
| Warwick | 28.217 | 152.033 | 0.69 | 18.8 | 22.9 | 28.6 | 37.3 |
| Inglewood | 28.417 | 151.083 | 0.67 | 18.6 | 22.6 | 28.1 | 36.6 |
| Goondiwindi | 28.550 | 150.300 | 0.64 | 18.2 | 22.1 | 27.4 | 35.6 |
| Stanthorpe | 28.667 | 151.933 | 0.75 | 19.6 | 23.9 | 30.0 | 39.3 |

Table B6 – 1 year, 5-day rainfall intensity, and default values for 75%, 80%, 85% & 90% 5-day rainfall depth

| Location | I _(1yr, 120hr) | R(75%) | R(80%) | R(85%) | R(90%) |
|-----------------------------|---------------------------|--------|--------|--------|--------|
| New South Wales/ACT: | | | | | |
| Lismore * | 1.56 | 28.6 | 35.3 | 45.2 | 60.2 |
| Taree * | 1.37 | 25.0 | 31.7 | 41.2 | 55.9 |
| Newcastle * | 1.21 | 24.4 | 30.5 | 38.9 | 51.8 |
| Bathurst * | 0.56 | 16.8 | 20.6 | 24.9 | 31.4 |
| Sydney * | 1.30 | 23.3 | 29.7 | 38.8 | 55.2 |
| Bega * | – | 19.5 | 24.6 | 32.5 | 46.2 |
| Albury * | 0.58 | 20.0 | 23.7 | 28.4 | 35.2 |
| Canberra | 0.54 | 16.9 | 20.4 | 25.1 | 32.3 |
| Victoria: | | | | | |
| Mildura | 0.32 | 14.0 | 16.6 | 20.0 | 24.9 |
| Bendigo | 0.41 | 15.2 | 18.2 | 22.1 | 27.9 |
| Sale | 0.46 | 15.8 | 19.0 | 23.3 | 29.6 |
| Melbourne | 0.55 | 17.0 | 20.6 | 25.4 | 32.6 |
| Warrnambool | 0.42 | 15.3 | 18.3 | 22.3 | 28.3 |
| Ballarat | 0.45 | 15.7 | 18.9 | 23.0 | 29.3 |
| Tasmania: | | | | | |
| Launceston | 0.48 | 16.1 | 19.4 | 23.7 | 30.3 |
| Hobart | 0.51 | 16.5 | 19.9 | 24.4 | 31.3 |
| South Australia: | | | | | |
| Port Augusta | 0.28 | 13.5 | 16.0 | 19.1 | 23.6 |
| Port Lincoln | 0.32 | 14.0 | 16.6 | 20.0 | 24.9 |
| Adelaide | 0.39 | 14.9 | 17.8 | 21.6 | 27.3 |
| Mt Gambier | 0.44 | 15.6 | 18.7 | 22.8 | 28.9 |
| Western Australia: | | | | | |
| Broome | 0.71 | 19.1 | 23.3 | 29.1 | 38.0 |
| Geraldton | 0.46 | 15.8 | 19.0 | 23.3 | 29.6 |
| Perth | 0.60 | 17.6 | 21.4 | 26.5 | 34.3 |
| Bunbury | 0.67 | 18.5 | 22.6 | 28.1 | 36.6 |
| Albany | 0.44 | 15.6 | 18.7 | 22.8 | 28.9 |
| Northern Territory: | | | | | |
| Darwin | 1.45 | 28.6 | 35.9 | 46.2 | 62.8 |
| Katherine | 1.01 | 22.9 | 28.4 | 36.0 | 48.0 |

* Rainfall depth (R) values sourced from Landcom (2004).

Table B7 – Typical single storm event volumetric runoff coefficients ^[1]

| Rainfall (mm) ^[2] | Soil Hydrologic Group (refer to Section A3.1, Appendix A) | | | |
|---------------------------------|---|-----------------------|-----------------------|-----------------|
| | Group A Sand | Group B Sandy loam | Group C Loamy clay | Group D Clay |
| 10 | 0.02 | 0.10 | 0.09 | 0.20 |
| 20 | 0.02 | 0.14 | 0.27 | 0.43 |
| 30 | 0.08 | 0.24 | 0.42 | 0.56 |
| 40 | 0.16 | 0.34 | 0.52 | 0.63 |
| 50 | 0.22 | 0.42 | 0.58 | 0.69 |
| 60 | 0.28 | 0.48 | 0.63 | 0.74 |
| 70 | 0.33 | 0.53 | 0.67 | 0.77 |
| 80 | 0.36 | 0.57 | 0.70 | 0.79 |
| 90 | 0.41 | 0.60 | 0.73 | 0.81 |
| 100 | 0.45 | 0.63 | 0.75 | 0.83 |

Notes: [1] Sourced from Fifield (2001) and Landcom (2004).

[2] Rainfall depth based on the nominated 5-day rainfall depth, $R_{(Y\%,5\text{-day})}$.

The coefficients presented in Table B7 apply **only** to the pervious surfaces with a low to medium gradient (i.e. < 10% slope). Light to heavy clays compacted by construction equipment should attract a volumetric runoff coefficient of 1.0. Loamy soils compacted by construction traffic should attract a volumetric runoff coefficient no less than those values presented for Group D soils.

For catchments with mixed surface areas, such as a sealed road surrounded by soils of varying infiltration capacity, a composite coefficient must be determined using Equation B9.

$$C_{V(\text{comp.})} = \frac{\sum(C_{V,i} \cdot A_i)}{\sum(A_i)} \quad (\text{B9})$$

where:

$C_{V(\text{comp.})}$ = Composite volumetric runoff coefficient

$C_{V,i}$ = Volumetric runoff coefficient for surface area (i)

A_i = Area of surface area (i)

The volumetric runoff coefficient for impervious surfaces directly connected to the drainage system (e.g. sealed roads discharging concentrated flow to a pervious or impervious drainage system) should be adopted as 1.0. The volumetric runoff coefficient for impervious surfaces **not** directly connected to the drainage system (e.g. a footpath or sealed road discharging sheet flow to an adjacent pervious surface) should be adopted as the average of the runoff coefficients for the adjacent pervious surface and the impervious surface (assumed to be 1.0).

If the coefficient is being determined for the design of a *Sediment Basin* established within a loamy or clayey soil catchment, then a volumetric runoff coefficient of 1.0 is recommended for all compacted soils and any areas exposed to heavy construction traffic.

Step 6 Determine the sediment storage volume

The “sediment storage zone” lies below the “settling zone” as defined in Figure B8. The recommended sediment storage volume may be determined from Table B8.

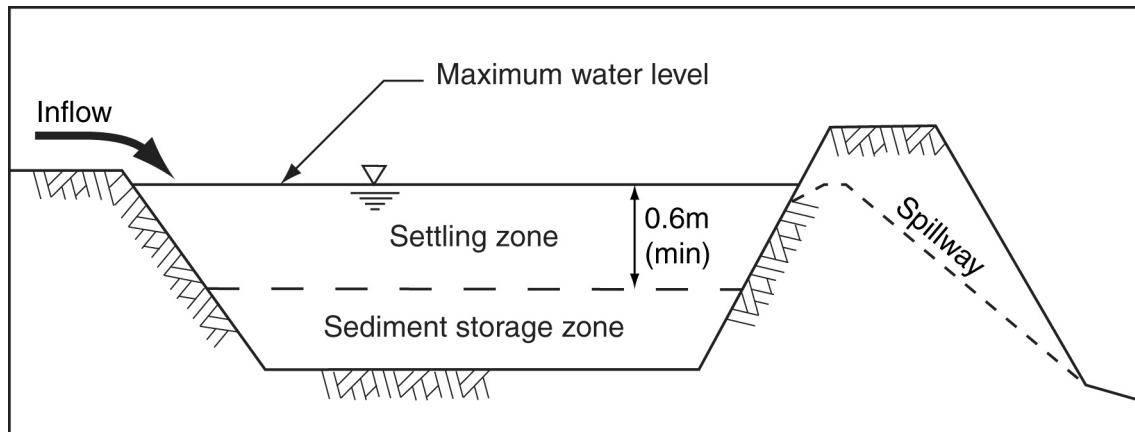

Figure B8 – Settling zone and sediment storage zone

Table B8 – Sediment storage volume

| Basin type | Sediment storage volume |
|-------------------|-------------------------|
| Type C | 100% of settling volume |
| Type F and Type D | 50% of settling volume |

Alternatively, the volume of the sediment storage zone may be determined by estimating the expected sediment runoff volumes over the desired maintenance period, typically not less than 2 months.

Appendix E – *Soil loss estimation* provides guidance on the estimation of sediment runoff volumes. The analysis should be based on the rainfall erosivity for the most erosive month during the period in which construction is likely to occur.

Discussion:

The sediment storage volume is usually not a critical component of the basin design because, if the volume is underestimated, then the consequences are usually only that the basin will require de-silting more regularly than originally expected. This of course represents a cost penalty to the construction contractor, but should not affect the basin's performance.

Step 7 Select internal and external bank gradients

Recommended bank gradients are provided in Table B9.

Table B9 – Suggested bank slopes

| Slope (H:V) | Bank/soil description |
|--------------------|---|
| 2:1 | Good, erosion-resistant clay or clay-loam soils |
| 3:1 | Sandy-loam soil |
| 4:1 | Sandy soils |
| 5:1 | Unfenced Sediment Basins accessible to the public |
| 6:1 | Mowable, grassed banks. |

All earth embankments in excess of 1 m in height must be certified by a geotechnical engineer/specialist as being structurally sound for the required design criteria and anticipated period of operation.

If public safety is a concern, and the basin is not to be fenced (not recommended), and the basin's internal banks are steeper than 5:1(H:V), then at least one bank should be turfed a width of at least 2 m from top of bank to the toe of bank to allow egress during wet weather.

Step 8 Design of flow control baffles

Baffles may be used for a variety of purposes including:

- energy dissipation (inlet chambers);
- the control of short-circuiting (internal baffles);
- minimising sediment blockage of the low-flow outlet structure (outlet chambers).

The need for flow control baffles should have been established in Step 5a based on the basin's length to width ratio. Both inlet baffles (inlet chambers) and internal baffles can be used to improve the hydraulic efficiency of the basin, and thus reduce the size of the settling pond through modification of the hydraulic efficiency correction factor (Step 5a).

Included in this section is a discussion on the design of *outlet chambers* which actually function as *sediment control baffles* rather than flow control baffles. These baffles are primarily used to prevent sediment blockage of the outlet system.

Design:

(a) Inlet chambers:

Flow control baffles or similar devices may be placed at the inlet end of a *Sediment Basin* to form an inlet chamber (Figures B9 to B12). These chambers are used to reduce the adverse effects of inlet jetting caused by concentrated, point source inflows. The objective of the inlet chamber is to produce near-uniform flow conditions across the width of the settling pond.

In most *Sediment Basins*, the coarser sediment particles quickly settle to form a sediment delta close to the inlet. However, if the inflow has sufficient energy and momentum, then this sediment can be washed further into the basin. In the worst case scenario, large volumes of sediment can settle around the main outlet structure increasing the expense and frequency of basin maintenance.

In Type C basins, inflow jetting can also promote the formation of dead water zones significantly reducing the hydraulic efficiency of the settling pond. As the length to width ratio decreases, the impact of these dead water zones increases.

Inflow jetting can also be a problem in Type F and D basins even though the sediment-laden water is normally retained for several days following the storm. During those storms when inflows exceed the storage volume of the basin, it is still important for the basin to be hydraulically efficient in order to maximise the settlement of the coarse sediment.

It is therefore always considered important to control the momentum of the inflow to:

- retain coarse sediments at the inlet end of the basin;
- limit the re-suspension of the finer, settled sediments;
- reduce short-circuiting within the basin; and
- reduce the frequency and cost of basin maintenance.

The main disadvantage of using an inlet chamber is that it can complicate the de-silting process, especially in small basins. Conversely, when used in large basins, an inlet chamber can reduce the long-term cost of de-silting operations by retaining the bulk of the coarse sediment within the inlet chamber where it can be readily removed by

equipment such as a backhoe. In large basins, the inlet chamber effectively operates as a pre-treatment pond.

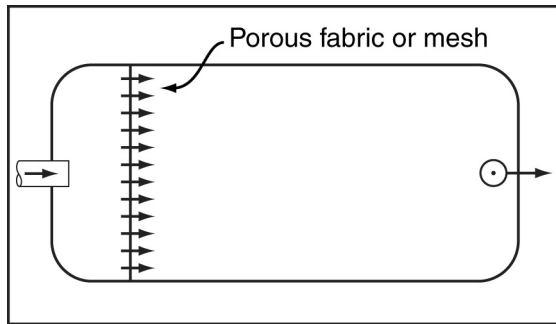

Figure B9(a) – Porous barrier inlet chamber

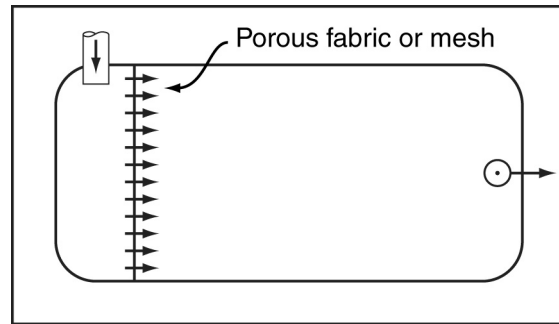

Figure B10(a) – Porous barrier with piped inflow entering from side of basin

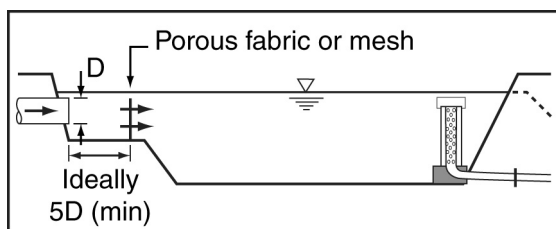

Figure B9(b) – Typical layout of inlet chamber with opposing inlet pipe (Type C basin)

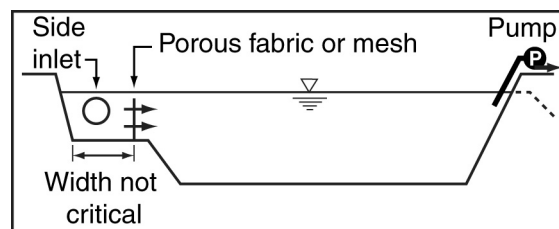

Figure B10(b) – Typical layout of inlet chamber with side inlet (Type F basin)

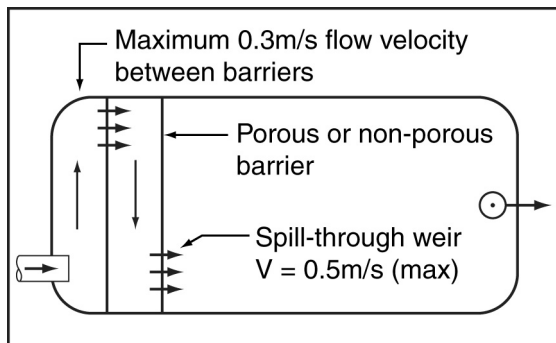

Figure B11(a) – Alternative inlet chamber design

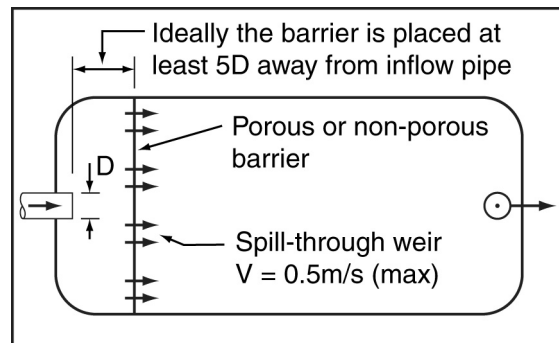

Figure B12(a) – Alternative inlet chamber design

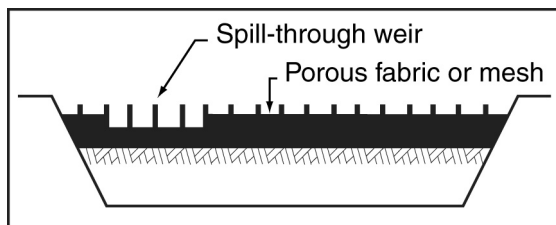

Figure B11(b) – Barrier with single spill-through weir per barrier

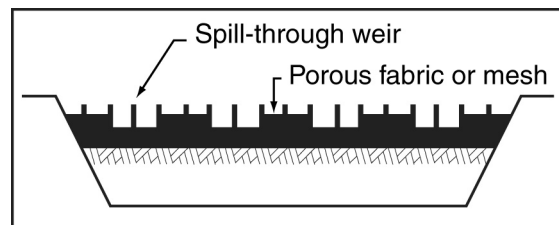

Figure B12(b) – Barrier with multiple spill-through weirs

The use of an inlet chamber is usually governed by the need to adopt a low hydraulic efficiency correction factor (H_e) in Step 5a. The incorporation of inlet baffles should be given serious consideration within Type C basins if the expected velocity of any concentrated inflows exceeds 1 m/s.

Table B10 summaries the design of various inlet chambers.

Table B10 – Design of various inlet chambers

| Baffle type | Description |
|---|--|
| Shade cloth | An inlet chamber formed by staking coarse shade cloth across the full width of the settling pond. Typical spacing between support posts is 0.5 to 1.0 m depending on the expected hydraulic force on the fence. |
| Perforated fabric | An inlet chamber formed from heavy-duty plastic sheeting or woven fabric. The sheeting/fabric is perforated with approximately 50 mm diameter holes at approximately 300 mm centres across the full width and depth of the settling pond (Figure B13). Typical spacing between support posts is 0.5 to 1.0 m depending on the expected hydraulic force on the fence. |
| Solid porous or non-porous barrier, with or without spill-through weirs | A porous or non-porous barrier constructed across the full width of the settling pond. If the inlet pipe is directed towards the barrier, then the barrier should ideally be located at least 5 times the pipe diameter away from the inflow pipe. The barrier is designed to ensure that the inflow is distributed evenly across the width of the basin and that the velocity of flow passing over the barrier does not exceed 0.5 m/s during the 1 in 1 year peak discharge. |

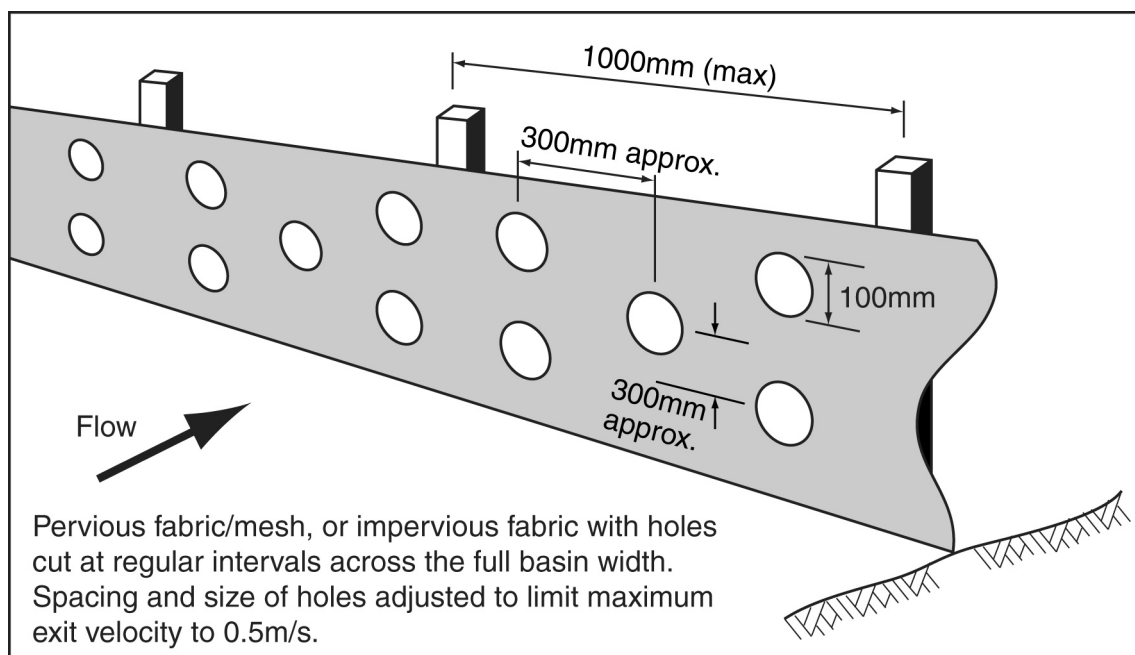

Figure B13 – Example arrangement of perforated fabric inlet baffle

The inlet chamber may have a pond depth less than the depth of the main settling pond (Figures B9b & B10b) in order to allow for easy installation and maintenance of the barrier. An inlet chamber depth of around 0.9 m will allow the use of standard width *Sediment Fence* fabric as the baffle material.

The use of shade cloth (width of around 2.2 m) will allow the formation of a deeper inlet chamber, thus potentially reducing the frequency of de-silting operations.

Inflow pipes should ideally have an invert well above the floor of the inlet chamber to avoid sedimentation within the pipe.

(b) Internal baffles:

Internal baffles are used to increase the effective length-to-width ratio of the basin. Figure B14 demonstrates the arrangement of internal flow control baffles for various settling pond layouts.

If internal baffles are used, then the flow velocity within the settling pond must not exceed the sediment scour velocity as defined in Table B11.

Table B11 – Sediment scour velocities

| Critical particle diameter (mm) | Scour velocity (m/s) |
|---------------------------------|----------------------|
| 0.10 | 0.16 |
| 0.05 | 0.11 |
| 0.02 | 0.07 |

The crest of these baffles should be set level with, or just below, the crest of the emergency spillway. This is to prevent the re-suspension of settled sediment during severe storms (i.e. flows in excess of the basin's design storm should be allowed to overtop these baffles).

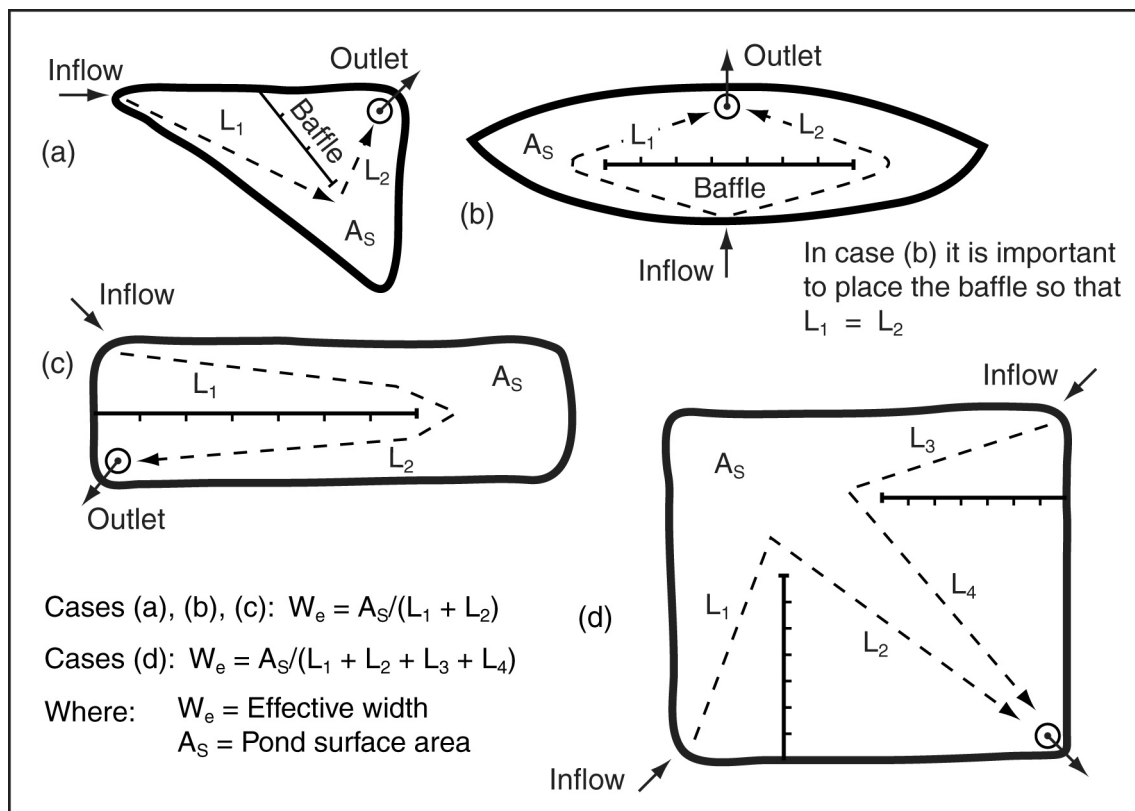

Figure B14 – Typical arrangement of internal flow control baffles (after USDA, 1975)

(c) Outlet chambers:

Outlet chambers (Figures B15 and B16) are used to keep the bulk of the settled sediment away from certain low-flow outlet systems, particularly riser pipe outlets and flexible skimmer pipe outlets.

Maintenance of a *Sediment Basin* can be expensive if the basin's low-flow outlet system becomes blocked with sediment, or if the outlet is damaged during the desilting operation. A sediment control barrier constructed around the outlet system limits the deposition of coarse sediment around the outlet structure, thus reducing maintenance costs and improving the long-term hydraulics of the basin.

The use of an outlet chamber is mandatory when a flexible skimmer pipe outlet system is employed.

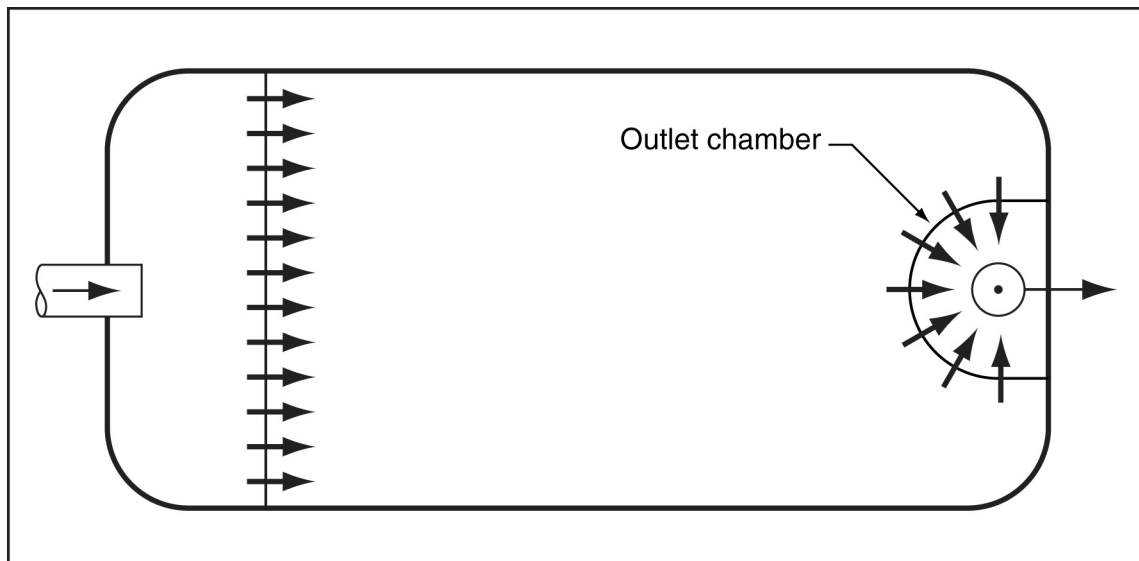

Figure B15 – Typical arrangement of outlet chamber (plan view)

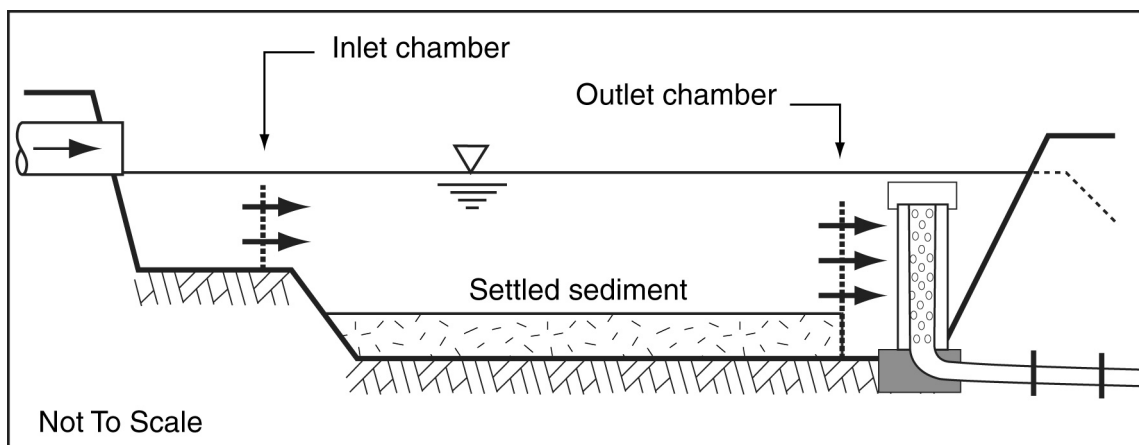

Figure B16 – Typical arrangement of outlet chamber (long section)

Step 9 Design the basin's inflow system

Surface flow entering the basin should not cause erosion down the banks of the basin. If concentrated surface flow enters the basin (e.g. via a *Catch Drain*), then an appropriately lined *Chute* will need to be installed at each inflow point to control scour.

If flow enters the basin through pipes, then wherever practicable, the pipe invert should be above the spillway crest elevation to reduce the risk of sedimentation within the pipe. Submerged inflow pipes must be inspected and de-silted (as required) after each inflow event.

Constructing an appropriately designed pre-treatment pond or inlet chamber (Step 8) can be used to both improve the hydraulic efficiency of the settling pond, and reduce the cost and frequency of de-silting the main settling pond.

Discussion:

Where space is available, the construction of an inlet (pre-treatment) pond or inlet chamber (Step 8) can significantly reduce the cost of regular de-silting activities for large and/or long-term basins. Figures B9–B12 and B17–B19 demonstrate typical arrangements. These ponds are designed to collect the bulk of the coarse sediment. Their size and location should allow de-silting by readily available on-site equipment such as a backhoe.

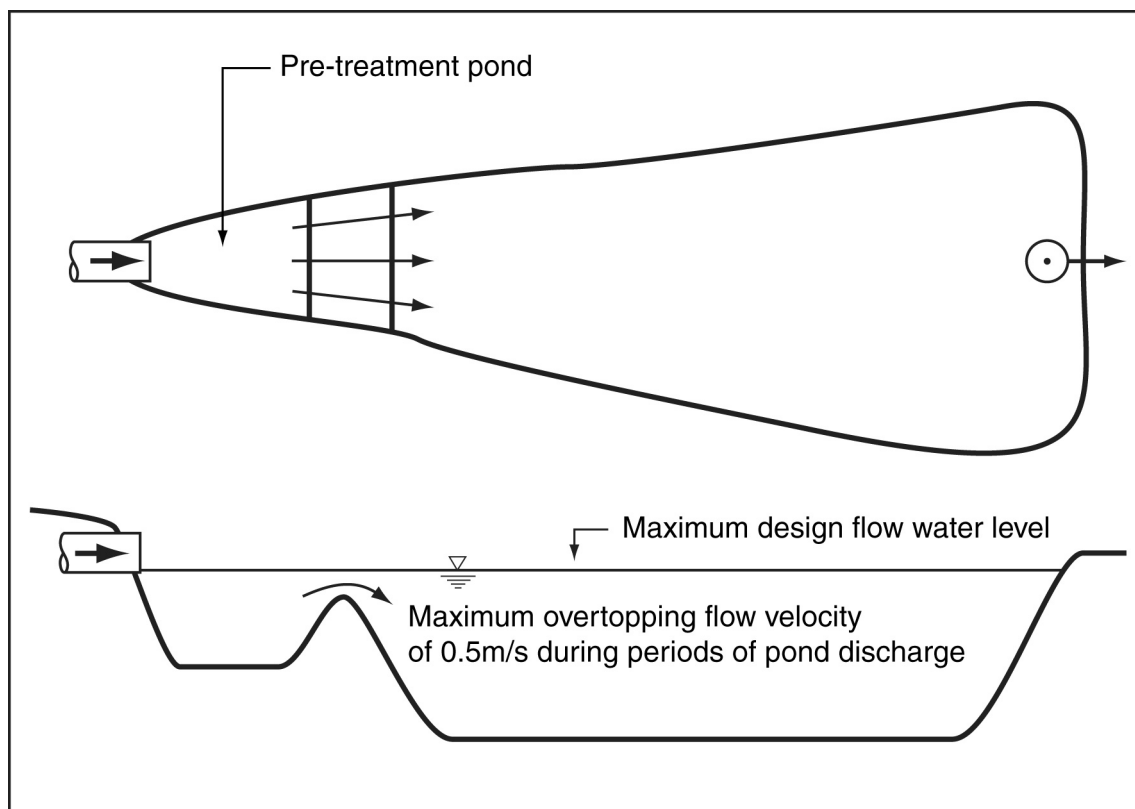

Figure B17 – Pre-treatment inlet pond

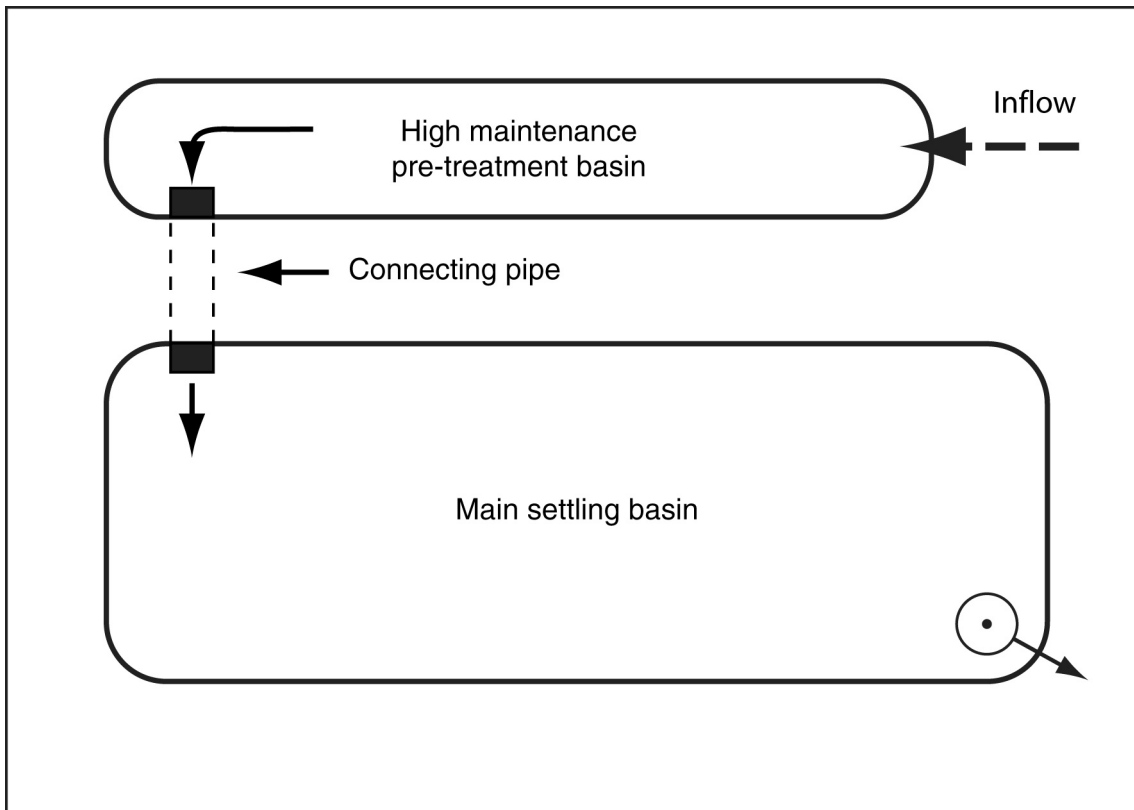

Figure B18 – Pre-treatment inlet pond

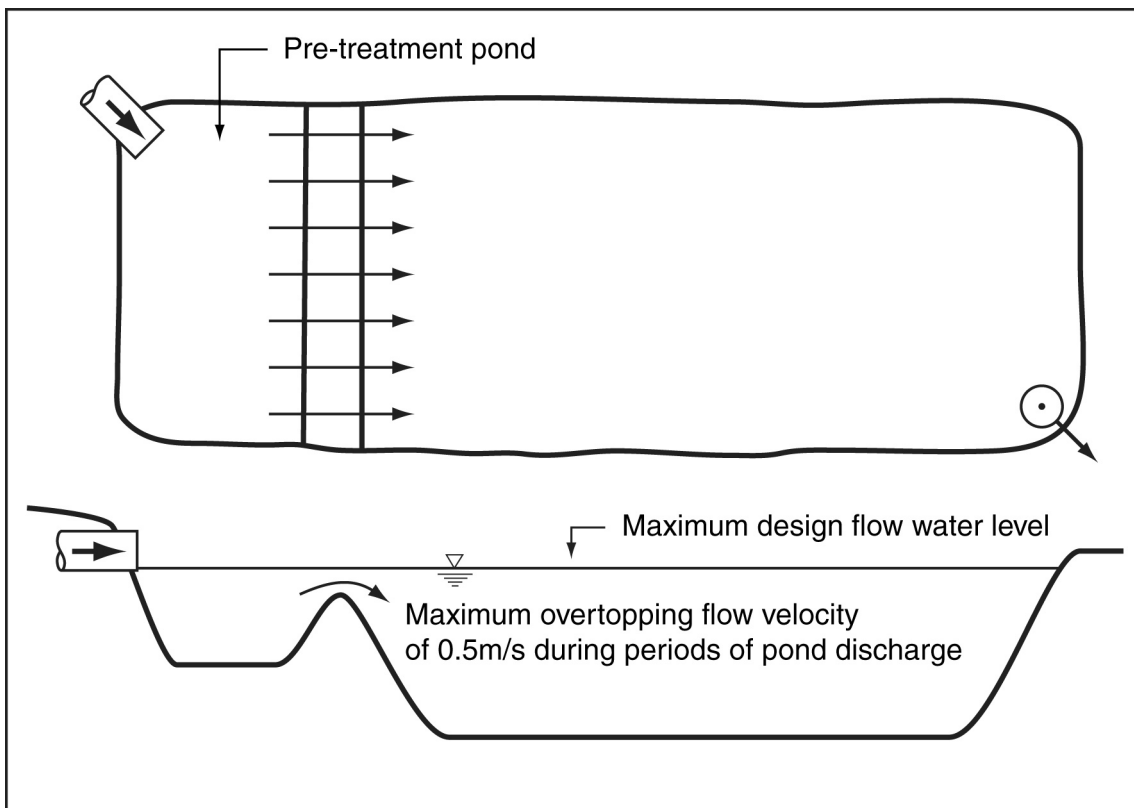

Figure B19 – Pre-treatment inlet pond

Step 10 Design the primary outlet system

Dry basins (Type C only) require a formal outlet system in the form of either a riser pipe outlet or floating siphon system (commercially available in the USA). Gabion wall, *Rock Filter Dam*, and *Sediment Weir* outlet systems are **not** recommended unless a Type 2 sediment retention system has been specified.

Wet basins (Type C, F or D) usually require a pumped outlet system. Alternatively, if a piped outlet exists, then a flow control valve must be fitted to the outlet pipe to allow full control of the basin discharge.

The hydraulics of a Type C basin's primary outlet system must ensure that the peak water level is at least 300 mm below the crest of the emergency spillway during the basin's nominated design storm.

A. Rock Filter Dam outlet systems (Type 2 system):

Rock Filter Dam outlet systems are suitable for Type 2 sediment traps only. In this system a filter wall is constructed as the primary outlet system for the basin. The upstream face of the rock dam is either lined with aggregate, or a layer of non-woven filter cloth. Hydraulic design of the *Rock Filter Dam* should be in accordance with the relevant Fact Sheet presented in Book 4.

Use of an upstream aggregate filter has the advantage of generally being easy to replace by machinery such as a backhoe, but such filters are best used only in sandy soils.

Use of non-woven filter cloth as the primary filter medium has the advantage of being cheaper than aggregate; however, its replacement can be very messy and sediment leaks may occur if the replaced filter cloth is not installed properly. The filter cloth is usually placed over a layer of aggregate of uniform rock size, which is used to maintain the desired decant rate.

Due to the difficulties of replacing the filter cloth during maintenance operations, multiple layers of filter cloth can be installed, thus allowing the upper (sediment-laden) layer to be removed during maintenance. This procedure is not always successful because fine sediments can pass through several layers of filter cloth partially blocking each layer. Such sediment blockage, however, may indicate that multiple layers of filter cloth are actually required to achieve the desired water quality.

B. Gabion wall outlet systems (Type 2 system):

Gabion wall outlet systems are suitable for Type 2 sediment traps only. The gabion walls should be lined on the inside with filter cloth, not aggregate or woven sediment fence fabric. The filter cloth should not be placed or anchored between the gabion baskets as this makes it very difficult to replace the filter cloth during maintenance.

Hydraulic design of gabion wall outlet systems should be in accordance with the relevant Fact Sheet presented for *Sediment Weirs* presented in Book 4.

C. Sediment Weir outlet systems (Type 2 system):

Sediment Weir outlet systems are similar in structure and use to a gabion wall outlet system. They should only be used as an outlet system for Type 2 sediment traps. Hydraulic design of the *Sediment Weir* should be in accordance with the relevant Fact Sheet presented in Book 4.

D. Floating siphon outlets:

Floating siphon outlet systems are designed to self-prime when the basin's water exceeds a predetermined elevation. These systems decant the basin by siphoning water from the top of the pond, thus always extracting the cleanest water. This also extends the settlement period by commencing decant procedures only when the pond level reaches the predetermined elevation.

Skimmer pipes contain moving parts; therefore, it is essential for these outlet systems to be housed inside an *outlet chamber* (Step 8) to prevent sediment deposition around the pipe.

Self-priming skimmer pipes are difficult to design and optimise. Commercial products are available in the USA that discharge at a rate of around 1.7L/s.

E. Pumped outlet systems:

When de-watering any type of *Sediment Basin* it is extremely important for the process not to resuspend previously settled sediment. Thus, intake pipes must be housed in an appropriate flow control chamber to prevent settled sediment being removed from the basin. Intake pipes must **not** be allowed to rest on the bottom of the basin, or in any other location that will allow the entrainment of settled sediment.

An appropriate housing chamber for an intake pipe may be formed from a section of PVC drainage pipe, sealed at one end, and perforated along its length with intake holes.

As an alternative, the inflow pipe may be suspended from a floating raft that is designed to prevent the intake pipe from resting too close to the settled sediment. The intake pipe is normally placed inside a horizontal perforated PVC pipe attached to the underside of a floating raft. Perforations in the PVC pipe would only exist along the top of the pipe, thus minimising the risk of settled sediment being entrained into the outlet.

Pumped outlet systems should aim to discharge the basin's settling zone volume in **less** than 24 hours. The outflow must not cause erosion or adversely affect downstream environments, including occupied properties.

F. Perforated riser pipe outlets:

Key components of a perforated riser pipe outlet are listed below:

- Anti-flotation mass = 110% of the displaced water mass.
- Combined trash rack and anti-vortex screen placed on top of open riser pipe.
- Minimum outlet pipe size of 250 mm.
- Anti-seep collars (minimum of 1) placed on the buried outlet pipe.
- Designed to drain the basin's full settling zone volume in not less than 24 hours (to allow adequate settlement time).

Design details for perforated riser pipe outlets are presented below.

- (a) Pipe size:** The minimum diameter of the outlet pipe should be 250 mm.
- (b) Freeboard to spillway crest** The top elevation of the riser pipe (or oil skimmer if used) should be a minimum 300 mm below the crest of the emergency spillway.
- (c) Hydraulic capacity and freeboard:** The primary outlet should be capable of discharging the peak flow from the relevant design storm when the pond water level is no less than 300 mm below the crest of the emergency spillway.
- The screened open top of the riser pipe (Figure B20) can be used as a siphon spillway for storms in excess of the basin's design storm. Note; the basin's design storm is different from the design storm for the emergency spillway.
- (d) Drainage holes:** Minor perforation holes should exist throughout both the settling zone and the sediment storage zone. The primary (i.e. largest) drainage holes are located at the base of the settling zone. These holes are sized using the orifice discharge formula (Equation B10 – Goldman et al. 1986).

$$A_o = \frac{A_s \sqrt{2H}}{C_d T \sqrt{g}} \quad (\text{B10})$$

where:

A_o = surface area of primary drainage holes [m²]

A_s = average surface area of the settling zone = V_s/h_s [m²]

V_s = volume of settling zone [m³]

h_s = depth of settling zone [m]

H = head of water above orifice [m]

T = de-watering time [hours]

C_d = discharge coefficient (adopt $C_d = 0.60$)

g = gravitational constant (9.8 m/s²)

Equation B10 does **not** provide an appropriate analysis of basin drainage when multiple primary holes are used at various depths throughout the settling zone.

The de-watering holes must **not** be directly covered by filter cloth, instead spacers should be used to separate the filter from the surface of the riser pipe (Figure B20).

All de-watering holes must be covered with wire mesh if aggregate is used at the primary filter.

De-watering of the sediment storage zone can be achieved by locating additional minor drainage holes within the sediment storage zone.

- (e) Primary filtration system:** An outlet riser pipe can be surrounded with a “pyramid” of aggregate (Figure B21), or a vertical stand of rock-filled gabion baskets wrapped in heavy-duty filter cloth (Figure B22).
- Alternatively, filter cloth can be used as the primary filter medium (Figures B20 and B22). Outlet systems that incorporate the use of filter cloth must give appropriate consideration of ongoing maintenance issues, including regular replacement of the filter cloth. It should be noted that maintenance and sediment blockage of the filter cloth will be reduced as the total surface area of the filter cloth is increased.
- The filter cloth must **not** be placed in direct contact with the riser pipe. An air gap is essential to ensure hydraulic efficiency of the filter cloth (Figure B23). Thus wire mesh should be wrapped around and secured to the perforated riser pipe before attaching the fabric.
- To assist in separating the filter cloth from the riser pipe, vertical timber spacers (Figure B23) can be placed between the riser pipe and wire mesh.
- (f) Oil skimmer:** An oil skimmer ring (Figures B20 and B24) is normally placed around the top of the riser pipe to minimise the risk of floating debris and oil from entering the riser pipe.
- (g) Debris screen:** A debris screen should be placed over the top of the riser pipe. Typically this screen is incorporated into the oil skimmer.
- (h) Anti-vortex device:** An anti-vortex plate should be fitted to the top of the riser pipe as shown in Figure B24.
- (i) Anti-flotation weight:** The design of any riser pipe system should include allowance for uplifting (buoyancy) forces on the structure in the form of a weighted concrete base. The weight of the anti-flotation mass (Figure B20) should be no less than 110% of the mass of water displaced by the riser pipe.
- Gabion baskets must be securely fastened to the riser pipe if they are to act as the anti-flotation weight.
- (j) Anti-seep collar:** At least 1 anti-seep collar must be placed on the riser pipe to prevent seepage along the outer surface of the pipe.

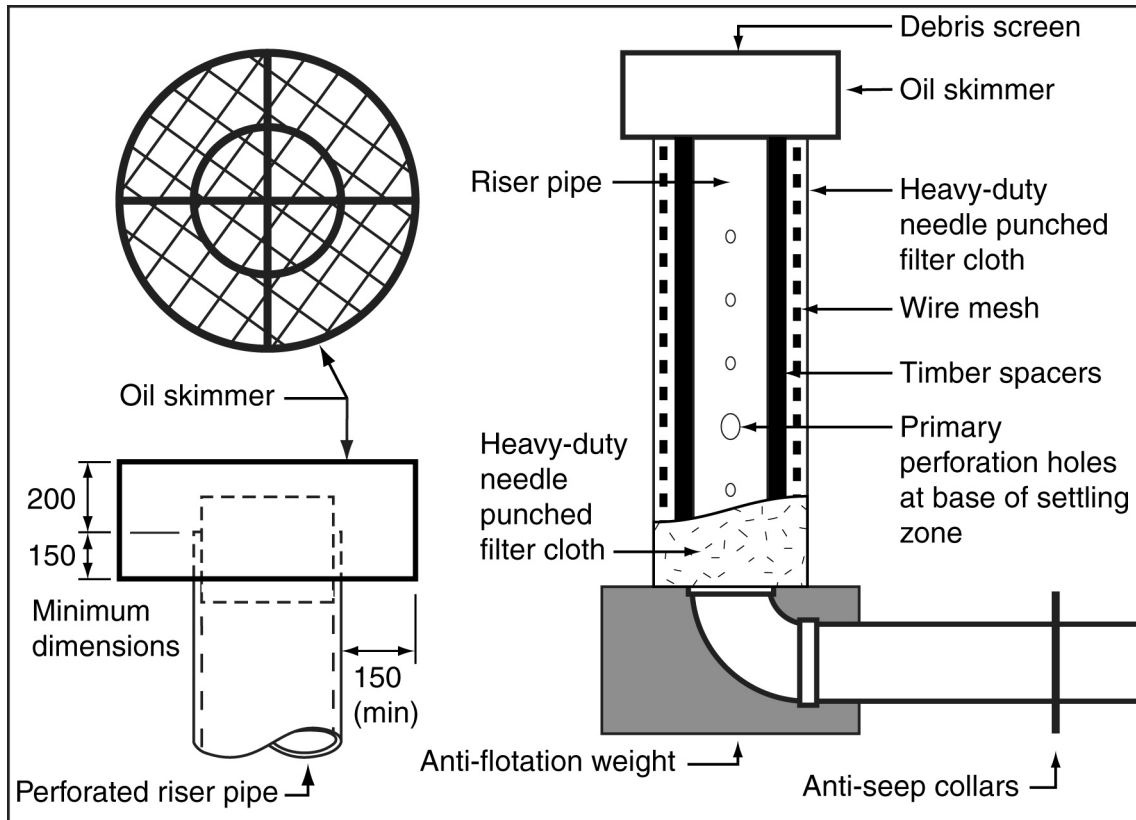

Figure B20 – Typical details of riser pipe outlet with fabric filter

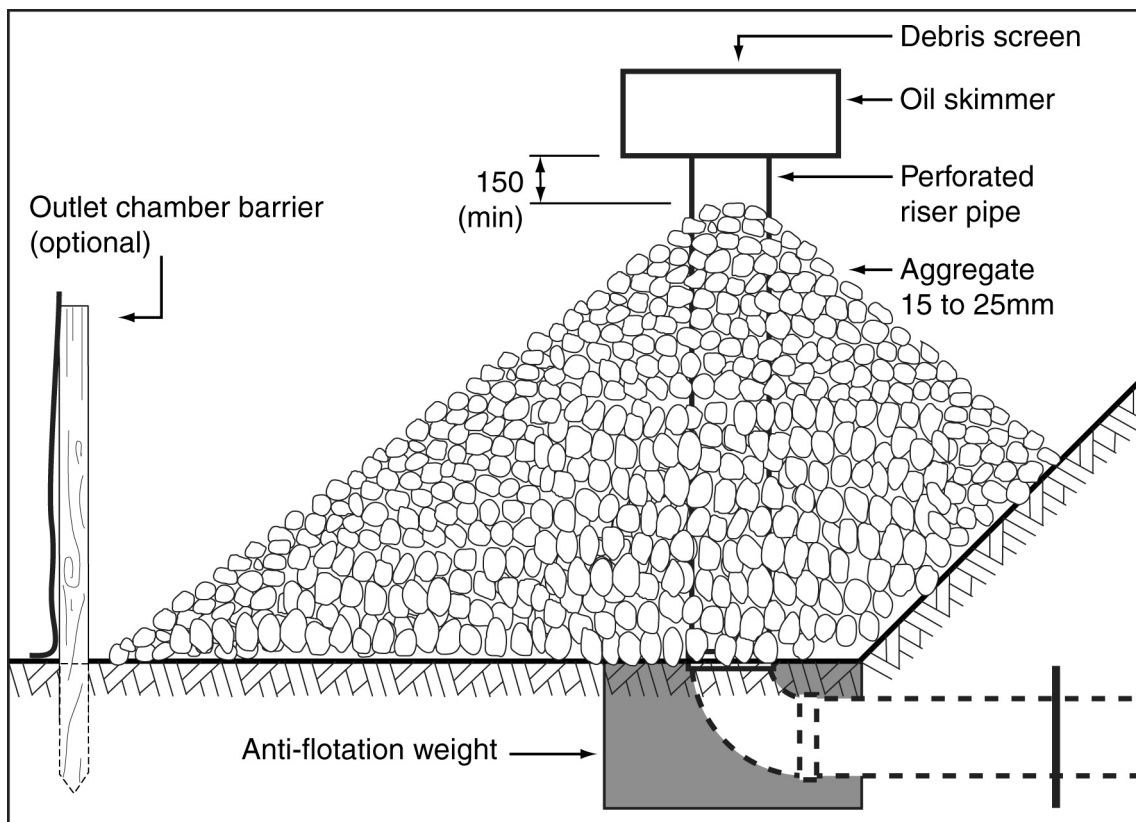

Figure B21 – Typical details of riser pipe outlet with aggregate filter

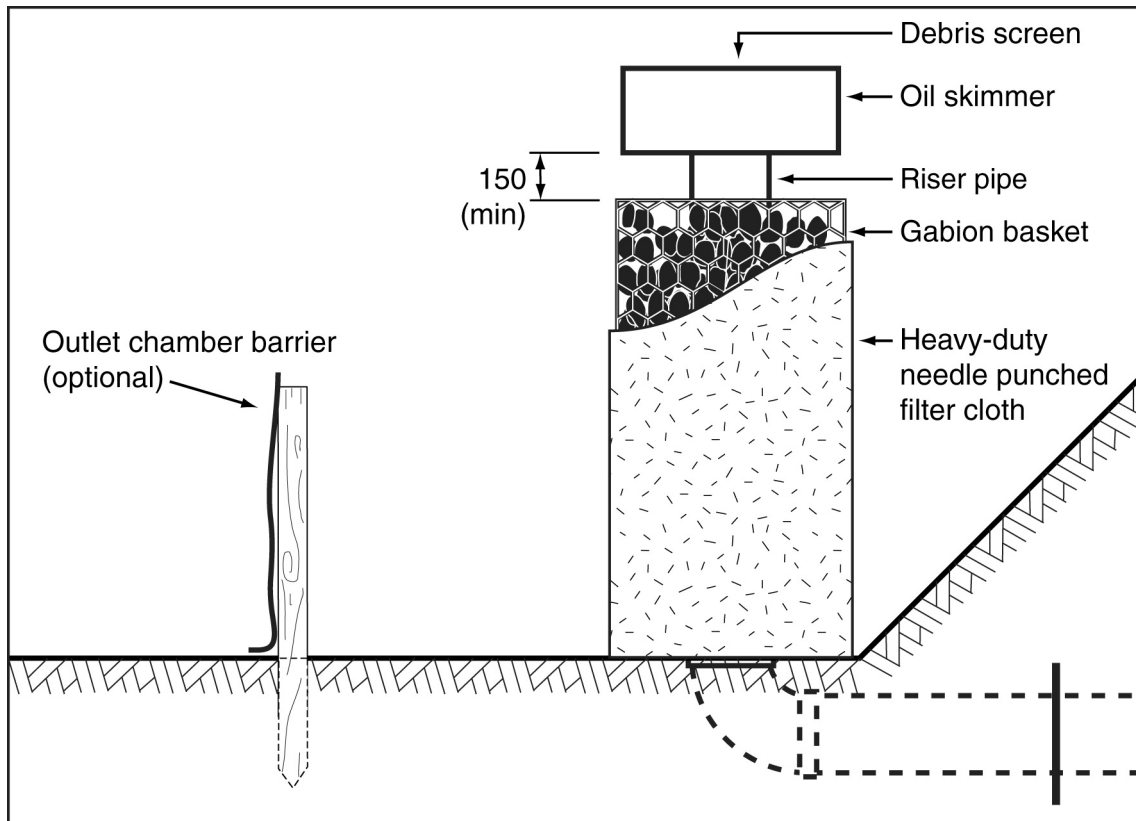

Figure B22 – Typical details of riser pipe outlet with rock-filled gabion baskets

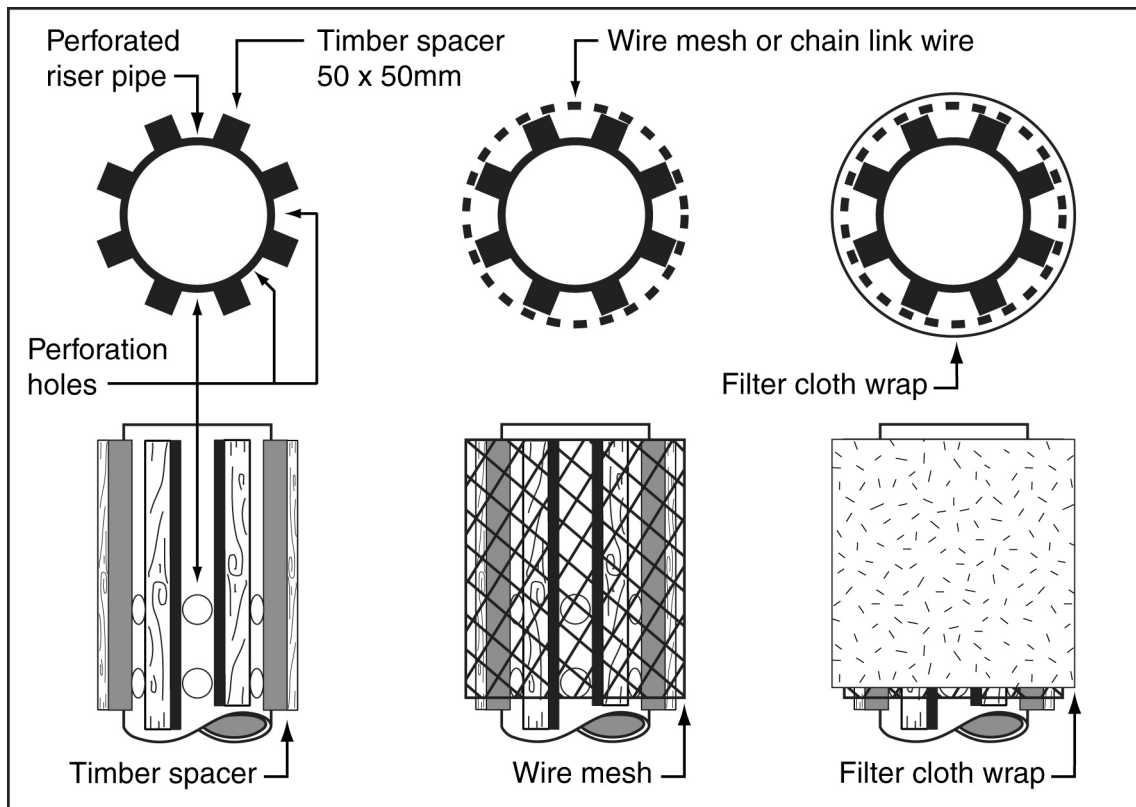

Figure B23 – Typical assembly of riser pipe with filter fabric

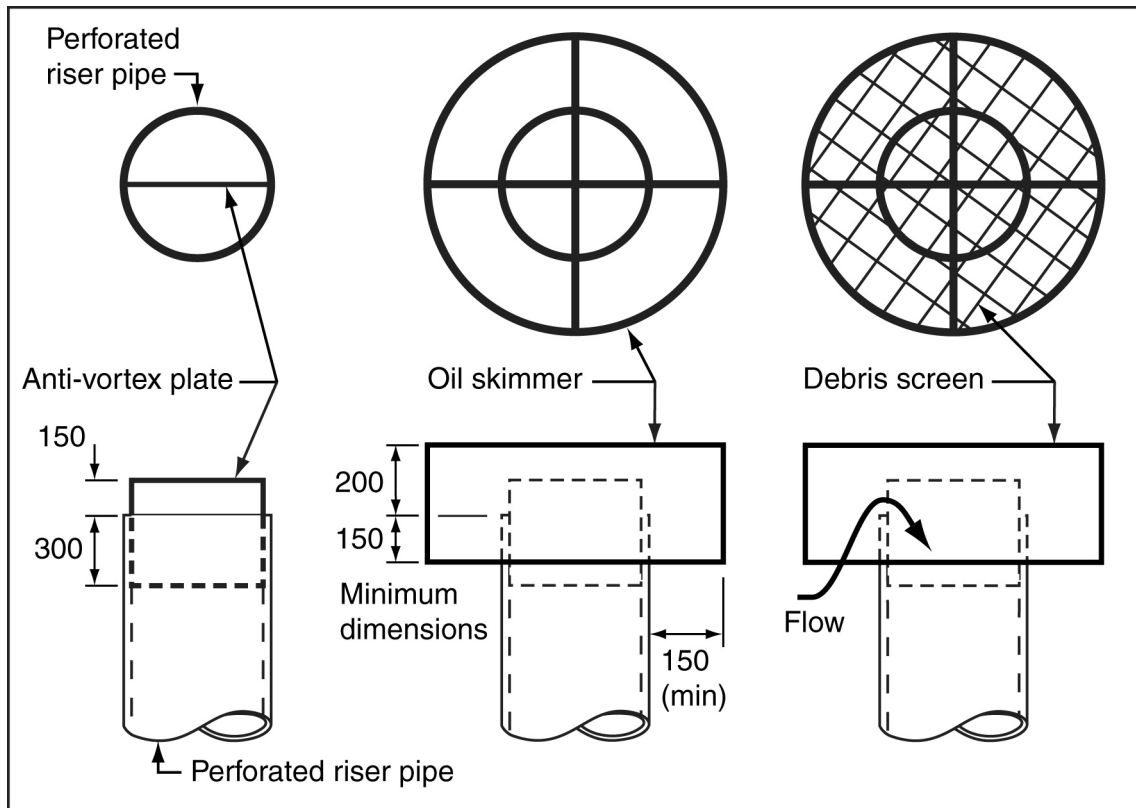

Figure B24 – Typical details of anti-vortex plate, oil skimmer and debris screen

Step 11 Design the emergency spillway

The minimum design storm for sizing the emergency spillway is defined in Table B12.

Table B12 – Recommended design standard for emergency spillways on temporary *Sediment Basins* *

| Design life | Minimum design storm ARI |
|--|------------------------------|
| Less than 3 months operation | 1 in 10 year |
| 3 to 12 months operation | 1 in 20 year |
| Greater than 12 months | 1 in 50 year |
| If failure is expected to result in loss of life | Probable Maximum Flood (PMF) |

* Alternative design requirements may apply to Referable Dams in accordance with State legislation, or as recommended by the Dam Safety Committee (ANCOLD 2000a & 2000b)

The crest of the emergency spillway is to be at least:

- 300 mm above the primary outlet (if included);
- 300 mm below a basin embankment formed in virgin soil;
- 450 mm below a basin embankment formed from fill.

In addition to the above, design of the emergency spillway must ensure that the maximum water level within the basin during the design storm specified in Table B12 is at least:

- 300 mm below a basin embankment formed from fill;
- 150 mm plus expected wave height for large basins with significant fetch length (note; significant wind-generated waves can form on the surface of large basins).

The approach channel can be curved upstream of the spillway crest, but must be straight from the crest to the energy dissipater as shown in Figure B25. The approach channel should have a back-slope towards the impoundment area of not less than 2% and should be flared at its entrance, gradually reducing to the design width at the spillway crest.

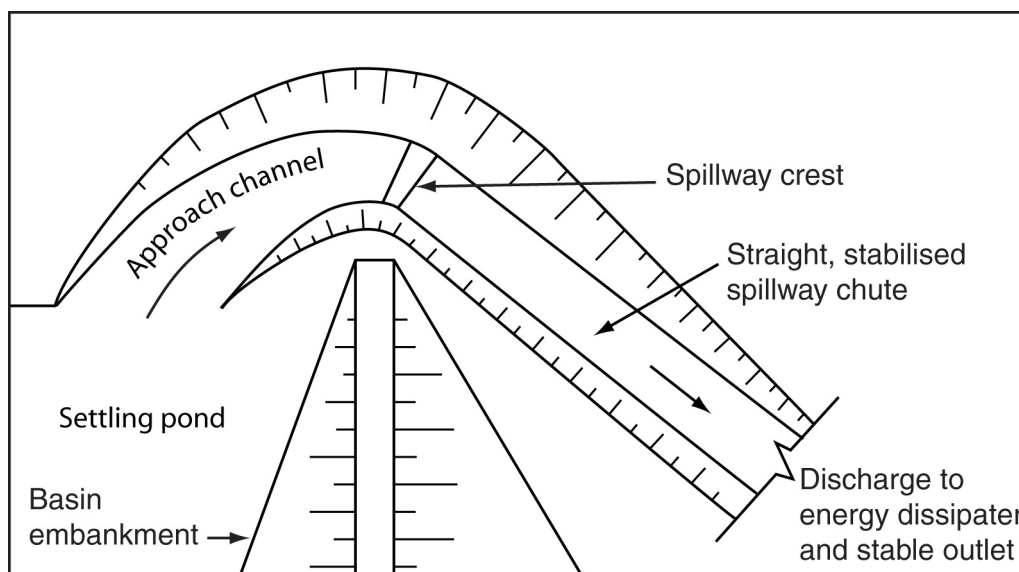

Figure B25 – Emergency spillway

All reasonable and practicable efforts must be taken to construct the spillway in virgin soil, rather than within a fill embankment. Placement of an emergency spillway within a fill embankment can significantly increase the risk of failure.

Anticipated wave heights may be determined from the procedures presented in the *Shore Protection Manual* (Department of the Army, 1984).

The hydraulic design of *Sediment Basin* spillways (Figure B26) is outlined in Section A5.4 of Appendix A – *Construction Site Hydrology and Hydraulics*.

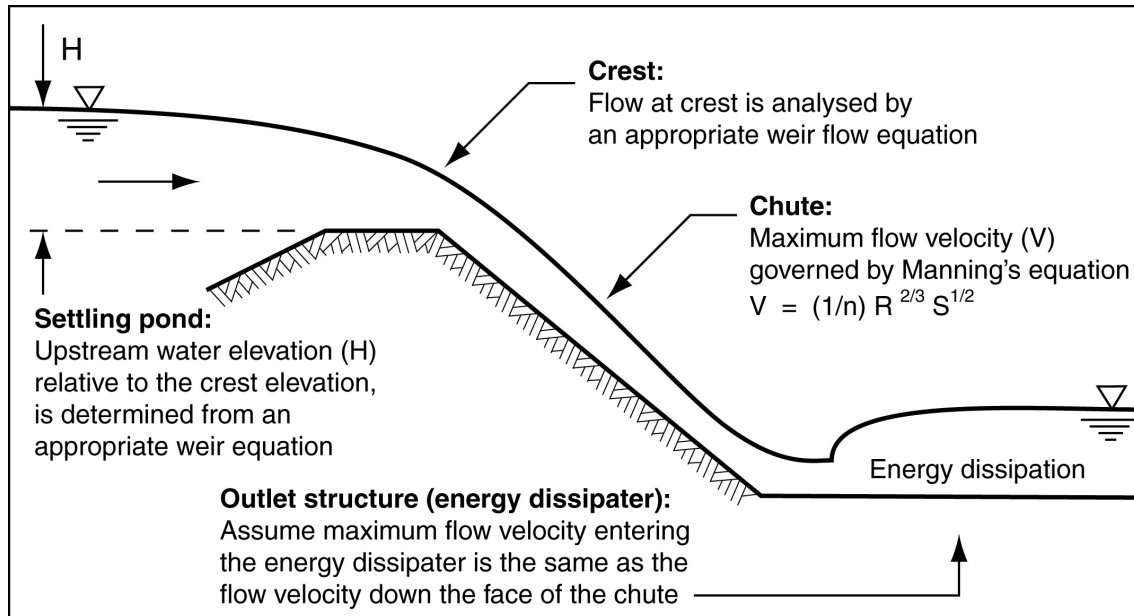

Figure B26 – Hydraulics of *Sediment Basin* spillways

The downstream face of the spillway may be protected with grass, concrete, rock, rock mattresses, or other suitable material as required for the expected maximum flow velocity. Grass-lined spillway chutes are generally not recommended for *Sediment Basins* due to their long establishment time and relatively low scour velocity.

Recommended freeboard down the spillway chute is 300 mm.

Technical Note B3 – Design of rock chutes

Care needs to be taken to ensure that flow passing through voids of the crest of a rock or rock mattress spillway does not significantly reduce the basin's peak water level, or cause water to discharge down the spillway before reaching the nominated spillway crest elevation.

Discussion:

Unlike permanent stormwater treatment ponds and wetlands, construction site *Sediment Basins* are **not** designed to allow high flows to bypass the basin. Even if the basin is hydraulically full, sediment-laden stormwater runoff should continue to be directed through the basin. This allows the continued settlement of coarse-grained particles contained in the flow. Thus a side-flow channel does not need to be constructed to bypass high flow directly to the spillway.

Step 12 Determine the overall dimensions of the basin

If a *Sediment Basin* is constructed with side slopes of say 3:1 (H:V), then a typical basin may be 5 to 10 m longer and wider than the length and width of the settling pond determined in Step 5. It is important to ensure the overall dimensions of the basin can fit into the available space.

The minimum recommended embankment crest width is 2.5 m, unless justified by hydraulic/geotechnical investigations.

Where available space does not permit construction of the ideal *Sediment Basin*, then a smaller basin may be used; however, erosion control and site rehabilitation measures must be increased to an appropriately higher standard to compensate. **If the basin's settling pond surface area/volume is less than that required in Step 5, then the basin must be considered a Type 2 or Type 3 sediment control system.**

Equations B11 to B14 (over page) can be used to determine the outer dimensions of the settling pond given a required storage volume (or vice-versa) for various geometric shapes.

Volume calculations for prismatic shapes:

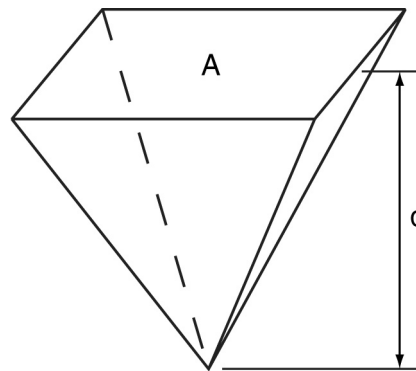
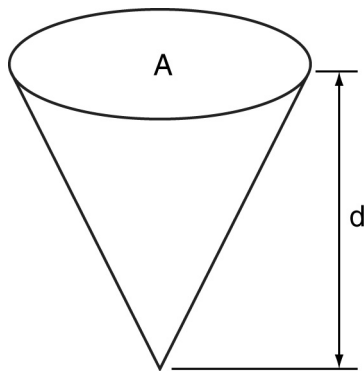

Volume (Eqn B11) =

$$V = (1/3).A.d$$

where:

- V** = volume [m³]
- A** = top surface area [m²]
- d** = depth of volume [m]

Volume (Equation B12) =

$$V = (1/3).W^2.d + (1/2).(L - W).W.d$$

where:

- W** = width of top surface [m]
- L** = length of top surface [m]

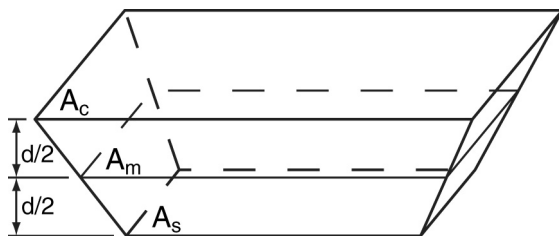
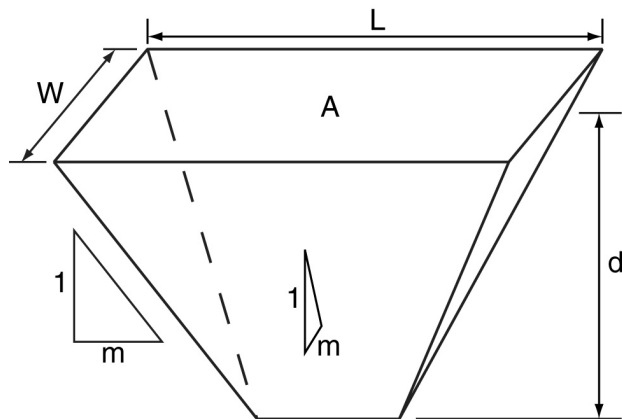

Simpson's Rule (Equation B13):

$$V = (d/6).(A_c + 4.A_m + A_s)$$

where:

- d** = depth of volume [m]
- A_c** = surface area at top of volume [m²]
- A_m** = surface area at mid depth [m²]
- A_s** = surface area at base of volume [m²]

Estimation of required basin depth (d) given pond surface area (A_s) and bank slope (m) (Equation B14)

$$d \approx \frac{-A_s + \sqrt{(A_s^2 + 2.P.m.V_b)}}{P.m}$$

where:

- P** = circumference of volume at base [m]
- V_b** = required basin volume [m³]
- m** = bank slope (constant) around the volume

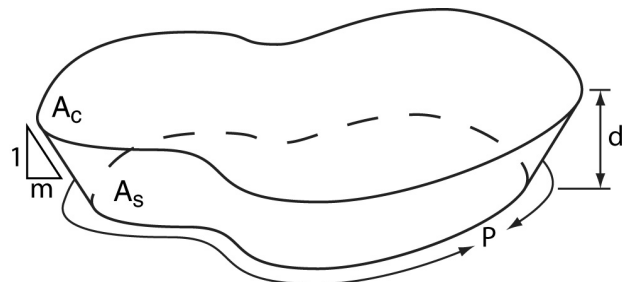

Step 13 Locate maintenance access (de-silting)

Sediment Basins can either be de-silted using long-reach excavation equipment operating from the sides of the basin, or by allowing machinery access into the basin. If excavation equipment needs to enter directly into the basin, then it is better to design the access ramp so that trucks can be brought to the edge of the basin, rather than trying to transport the sediment to trucks located at the top of the embankment. Thus a maximum 6:1 (ideally 10H:1V) access ramp will need to be constructed.

If the sediment is to be removed from the site, then a suitable sediment drying area should be made available adjacent to the basin, or at least somewhere within the basin's catchment area.

Step 14 Define the sediment disposal method

Trapped sediment can be mixed with on-site soils and buried, or removed from the site. If sediment is removed from the site, then it should be de-watered prior to disposal. De-watering must occur within the catchment area of the *Sediment Basin*.

Step 15 Assess need for safety fencing

Construction sites are often located in publicly accessible areas. In most cases it is not reasonable to expect a parent or guardian of a child to be aware of the safety risks associated with a neighbouring construction site. Thus fencing of a *Sediment Basin* is usually warranted even if the basins are located adjacent to other permanent water bodies such as a stream, lake, or wetland.

Responsibility for safety issues on a construction site ultimately rests with the site manager; however, each person working on a site has a duty of care in accordance with the State's work place safety legislation. Similarly, designers of *Sediment Basins* have a duty of care to investigate the safety requirements of the site on which the basin is to be constructed.

Step 16 Define the rehabilitation process for the basin area

The Erosion and Sediment Control Plan (ESCP) needs to include details on the required decommissioning and rehabilitation of the *Sediment Basin* area. Such a process may involve the conversion of the basin into a component of the site's permanent stormwater treatment network.

On subdivisions and major road works, construction site *Sediment Basins* often represent a significant opportunity for conversion into either: a detention/retention basin, bioretention system, wetland, or pollution containment system. In rural areas, basins associated with road works are often constructed within adjacent properties where they remain under the control of the landowner as permanent farm dams.

Technical Note B4 – Pollution containment systems

Technically, pollution containment systems are not part of the stormwater treatment network because treatment of the pollutant does not occur on-site. Instead, the pollutant (usually liquid spills from traffic accidents) is contained within these devices for later removal and treatment and/or disposal off-site.

Detention/retention basins and wetlands can operate as pollution containment systems by modifying the outlet structure such that emergency services (e.g. EPA or fire brigade) can manually shut-off the outlet (usually with stop boards or sandbags) thus containing any pollutants within the basin.

Sediment Basins that are to be retained or transformed into part of the permanent stormwater treatment system, may be required to pass through a staged rehabilitation process as outlined in Tables B13 and B14.

In those circumstances where it is necessary to temporarily protect newly constructed permanent stormwater treatment devices (such as bioretention systems and wetlands) from sediment intrusion, there are a number of options as outlined in Table B15.

With appropriate site planning and design, the protection of these permanent stormwater treatment devices is generally made easier if the *Sediment Basin* is designed with a pre-treatment inlet pond as discussed in Step 9. The pre-treatment pond can remain as a coarse sediment trap during the maintenance and building phases, thus protecting the newly formed wetland or bioretention system located within the basin's main settling pond.

Continued operation of the *Sediment Basin* during the building phase of subdivisions (i.e. beyond the specified maintenance phase) is an issue for negotiation between the regulatory authority and the land developer on a case-by-case basis. Ultimately, the responsibility for the achievement of specified (operational phase) water quality objectives rests with the current land owner or asset manager.

During the construction, decommissioning, rehabilitation, or reconstruction of a *Sediment Basin*, the basin area including settling pond, embankment and spillway, must be considered a "construction site" in its own right. Thus, these works must comply with the drainage, erosion, and sediment control standards outlined in Chapter 4 – *Design standards and technique selection*. This means that appropriate temporary sediment control measures will be required down-slope of the *Sediment Basin* during its construction and decommissioning.

Upon decommissioning of a *Sediment Basin*, all water and sediment must be removed from the basin prior to removal of the embankment (if any). Any such material, liquid or

solid, must be disposed of in a manner that will not create an erosion or pollution hazard.

Table B13 – Modification of basin during construction phase (site not including a building phase)

| | | |
|----------------|---------------------------|--|
| Stage 1 | Construction phase | <ul style="list-style-type: none"> • Basin operated as per the specifications of the ESCP and as required within this appendix to satisfy a Type 1 sediment trap. • If an alternative, permanent, outlet structure is to be constructed prior to stabilisation of the up-slope catchment area, then this outlet structure must not be made operational if it will adversely affect the required operation of the <i>Sediment Basin</i>. • The permanent stormwater treatment features (e.g. vegetation and filtration media) must be appropriately protected from the adverse effects of sediment runoff in accordance with the requirements of the proposed asset manager. It is usually considered insufficient to protect filter media by surrounding it with a Type 3 sediment control system. • The basin must not be modified to a Type 2 sediment trap (i.e. a <i>Sediment Basin</i> with surface area and/or volume less than that required by this appendix) until the assessed sediment runoff rate from the contributing catchment is less than the trigger value for a Type 1 sediment trap (refer to Tables 4.5.1 and 4.5.2, Chapter 4, as appropriate). • The basin must not be decommissioned until all up-slope site stabilisation measures have been implemented and are appropriately working to control soil erosion and sediment runoff in accordance with the specified ESC standard. This clause may require the basin to be fully operational during part of the maintenance and operational phases. |
| Stage 2 | Maintenance phase | <ul style="list-style-type: none"> • Until such conditions are achieved where the basin can be decommissioned (as per above) the permanent stormwater treatment features (e.g. vegetation and filter media) must be appropriately protected from the adverse effects of sediment runoff in accordance with the requirements of the proposed (operational phase) asset manager. It is usually considered insufficient to protect filter media by surrounding it with a Type 3 sediment control system. • Upon suitable conditions being achieved within the basin's catchment area, the operational features of the permanent stormwater treatment system are to be made fully operational (i.e. maintenance and/or reconstruction as required). |

Table B14 – Modification of basin during construction phase followed by a building phase

| | | |
|---------|---|--|
| Stage 1 | During construction phase | <ul style="list-style-type: none"> • Basin operated as per the specifications of the ESCP and as required within this appendix to satisfy a Type 1 sediment trap. • If an alternative, permanent, outlet structure is to be constructed prior to stabilisation of the up-slope catchment area, then this outlet structure must not be made operational if it will adversely affect the required operation of the <i>Sediment Basin</i>. • The permanent stormwater treatment features (e.g. vegetation and filtration media) must be appropriately protected from the adverse effects of sediment runoff in accordance with the requirements of the proposed asset manager. It is usually considered insufficient to protect filter media by surrounding it with a Type 3 sediment control system. • The basin must not be modified to a Type 2 sediment trap (i.e. a <i>Sediment Basin</i> with surface area and/or volume less than that required by this appendix) until the assessed sediment runoff rate for the contributing catchment is less than the trigger value for a Type 1 sediment trap (refer to Tables 4.5.1 and 4.5.2, Chapter 4, as appropriate). • The basin must not be decommissioned until all up-slope site stabilisation measures have been implemented and are appropriately working to control soil erosion and sediment runoff in accordance with the specified ESC standard. This clause may require the basin to be fully operational during part of the maintenance and operational phases. |
| Stage 2 | Maintenance phase whether pre, or during the during building phase | <p>Default condition:</p> <ul style="list-style-type: none"> • The permanent stormwater treatment features of the rehabilitated basin must not be made operational until all up-slope site stabilisation measures have been implemented and are appropriately working to control soil erosion and sediment runoff in accordance with the specified ESC standard. • Until such conditions are achieved where the basin can be decommissioned, the permanent stormwater treatment features (e.g. vegetation and filtration media) must be appropriately protected from the adverse effects of sediment runoff in accordance with the requirements of the proposed asset manager. It is usually considered insufficient to protect filter media by surrounding it with a Type 3 sediment control system. <p>Alternative operational condition:</p> <ul style="list-style-type: none"> • Upon the approval of the proposed (operational phase) asset manager and the regulatory authority, the newly constructed permanent stormwater treatment features of the basin may be made operational if such actions do not prevent the site from operating at the required sediment control standard. |
| Stage 3 | Immediately prior to completion of maintenance phase | <ul style="list-style-type: none"> • Upon suitable conditions being achieved within the basin's catchment area, the operational features of the permanent stormwater treatment system are to be made fully operational (i.e. maintenance and/or reconstruction as required). |

Table B15 – Options for the temporary protection of newly constructed permanent stormwater treatment devices

| Options | Comments |
|--|---|
| On-line operation with no protection or coarse sediment controls | <ul style="list-style-type: none"> • Generally requires the full reconstruction of the permanent stormwater treatment device at the end of the maintenance period. • Plant establishment within the wetland or bioretention system must be delayed until sediment intrusion is basically under control. • May require significant maintenance or full reconstruction following completion, or near completion, of the building phase. • This option can provide good water quality controls and protection of receiving waters during the building phase. |
| On-line operation with placement of temporary surface protection over filter media | <ul style="list-style-type: none"> • Filter media typically covered by heavy-duty filter cloth and minimum 200 mm layer of earth or sacrificial filter media. • Rehabilitation of the permanent stormwater treatment device at the end of the maintenance period is cheaper due to protection of the filter media. • Plant establishment within the wetland, bioretention or biofiltration system must be delayed until sediment intrusion is basically under control. • This option can provide moderate to high water quality controls and protection of receiving waters during the building phase. |
| On-line operation with temporary up-slope coarse sediment trap | <ul style="list-style-type: none"> • Often the preferred option when the <i>Sediment Basin</i> includes a pre-treatment inlet pond (refer to Figures B17 to B19 in Step 9). • Adequate protection of the filter media is generally only achieved through the use of a Type 2 sediment control system. • On bioretention/biofiltration systems, protection of the filter media can be improved by placing <i>Filter Tubes</i> or a <i>Filter Tube Dam</i> down-slope of the coarse sediment trap. The filter tubes may be allowed to lie between the newly established plants, directly over the filter media. • In high clay content soils in may still be necessary to rehabilitate the permanent stormwater treatment device at the end of the maintenance and building periods. • This option may allow early establishment of plants within the wetland or bioretention system. • This option can provide good water quality controls and protection of receiving waters during the building phase. |
| Off-line operation (full bypassing) | <ul style="list-style-type: none"> • No water quality benefit is obtained from the newly constructed permanent stormwater treatment devices. • Generally this is the lowest cost option with respect to the construction and maintenance of the permanent stormwater treatment system; however, overall site costs can be high due to the need to maintain separate sediment control measures (i.e. basins) during the maintenance and building phases. • On bioretention/biofiltration systems, higher water quality benefits can be achieved by integrating <i>Filter Tubes</i> into the flow bypass system, thus allowing limited treatment of those flows entering the <i>Filter Tubes</i>. The <i>Filter Tubes</i> are likely to be subject to blockage by coarse sediment unless their inlets are appropriately elevated above the level of expected coarse sediment deposition. |

Step 17 Define the basin's operational procedures

Sediment Basins can be operated as either “dry” or “wet” basins as described below.

- Dry basins are free draining basins that allow water to commence discharging from the low-flow outlet system as soon as water enters the basin.
- Wet basins are designed to retain sediment-laden water for extended periods allowing adequate time for the gravitational settlement of fine sediment particles. Operation of these basins may be assisted through the use of chemical flocculants. Ideally these basins are not drained until a suitable water quality is obtained within the basin.

Type F and Type D basins must be operated as wet basins with the settled/treated water decanted from the basin as soon as a suitable water quality is achieved. Thus, as soon as conditions allow, the basin must be maintained in either a dry-bed condition, or with a water level no greater than the top of the sediment storage zone (i.e. bottom of the settling zone, as discussed in Step 6).

On each occasion when a Type F or Type D basin cannot be de-watered prior to being surcharged by a following rainfall event, the operator must record such an event and report it to the appropriate regulatory authority. Where appropriate, alternative operating procedures may need be adopted in consultation with the regulatory authority in order to achieve optimum environmental protection.

A Type C basin may be operated as either a dry basin or wet basin; however, when operated as a wet basin, the settled water does not necessarily need to be decanted from the settling pond after achieving the desired water quality. This means that the water can be retained on-site for revegetation purposes and dust control.

A Type C basin operating in a wet condition is still sized in accordance with the design requirements for a normal Type C basin; however, a low-flow drainage system is not necessarily incorporated into the basin, thus potentially saving significant construction and maintenance costs.

Table B16 provides a summary of the attributes of the various operational conditions.

Table B16 – Attributes of various types of *Sediment Basins*

| Attribute | Type C dry basin | Type C wet basin | Type F and Type D wet basins |
|---|--|--|--|
| Soil type within catchment | Sandy soils | Sandy soils | Clayey or dispersive soils |
| Critical design parameter | Surface area at base of settling zone | Surface area at base of settling zone | Volume of settling zone |
| Desirable water level condition before a storm | Empty | Any condition | No greater than top of sediment storage zone |
| De-watering system | Low-flow piped drainage system (riser pipe) | Pumping | Pumping |
| Chemical flocculation | Only if specified water quality objectives fail to be achieved | Only if specified water quality objectives fail to be achieved | As necessary, but usually required for Type D basins |

Type F and D basins are typically designed for a maximum 5-day cycle, that being the filling, treatment and discharge of the basin within a maximum 5-day period. In some tropical regions this may not be practicable, and either a shorter or longer time frame may be required. The use of a shorter time period usually requires application of fast acting flocculants, which may require a much higher degree of environmental management compared to gypsum. The use of a longer time period will require the construction of a significantly larger basin.

Appropriate flocculation of *Sediment Basins* is required if the contained water does not achieve a specified water quality standard, usually 50 mg/L. Flocculation may consist of a variety of chemical agents as outlined in Table B17.

**Table B17 – Characteristics of various flocculating agents
(adapted from Freeman and Howells, 1995)**

| Agent | Indicative dosage | Comments | Precautions and constraints |
|--|---|--|--|
| Gypsum calcium sulphate, CaSO ₄ (2+) | Approximately 32kg per 100m ³ | Little pH change. Slight increase in salinity. | Needs to be spread evenly across pond. Can cause scum deposits in equipment. |
| Lime calcium hydroxide Ca(OH) ₂ (2+) | as for gypsum | Causes an increase in water pH. Slight increase in salinity. | Requires constant stirring due to partial solubility. |
| Polyelectrolytes long chain natural and synthetic organic polymers (>3+) | 0.05 to 0.2 kg per 100 m ³ | Careful preparation needed and adequate mixing with water body needed; little pH or salinity change; might be toxic. | Some may have restricted use due to possible monomer impurities. Do not overdose. |
| Polyacrylamides (PAMS) | Seek manufacturer's advice on application rates, applicability to site conditions and required environmental controls. | | |
| Alum aluminium sulfate Al ₂ (SO ₄) ₃ (3+) | 1.5 to 8 kg per 100 m ³ | Produces stable sludge that binds pollutants, optimum pH of 6.0 to 7.4. Do NOT overdose because pH will be lowered. | Likely toxic impacts on ecology at pH levels < 5.5 due to release of dissolved aluminium. Must only be used in controlled conditions. [1] |
| Ferric chloride FeCl ₃ (3+) | 1 to 3 kg per 100 m ³ | Water pH greater than 5.0 is required otherwise it might lower oxygen levels. | Is very corrosive, needs rubber or glass containment. Do not overdose. [1] |
| Ferric sulfate Fe ₂ (SO ₄) ₃ (3+) | 1 to 2.5 kg per 100 m ³ | Water pH greater than 5.0 is required. | Stored in wooden containers. Do not overdose. [1] |
| Salt sodium chloride, NaCl (1+) | Minimum of 5.25 m ³ seawater per 100 m ³ of fresh water (approx. 1800 mg/L of salt) | Flocculation is complete for some clays with salinity above 2000 to 3000 mg/L. Little extra benefit is gained when the salinity is above 10,000 mg/L. | Only used when the Sediment Basin discharges directly to seawater. Note: seawater contains approximately 35,000 mg/L salt. |

Note: [1] Control of water pH is critical prior to any discharge.

Even if soil conditions satisfy the initial selection of a Type C basin, this does not guarantee that the water quality achieved by the basin will satisfy the required environmental objectives. In cases where a poor discharge water quality is achieved, the basin may need to be operated as if it was a Type F or Type D basin in order to satisfy specified water quality objectives. Similarly, an existing Type F basin may need to be operated as a Type D basin if it fails to achieve its specified water quality objectives.

An appropriately marked (e.g. painted) de-silting marker post must be installed in the basin to indicate the top of the sediment storage zone. The basin must be de-silted if the next storm is likely to cause sediment to settle above this marker point, or if the sediment is already above this marker point.

Prior to discharge of water from a *Sediment Basin*, it is essential for the water quality to comply with all specified water quality objectives (WQOs) (e.g. water pH in the range of 6.5–8.5).

The recommended water quality standard for *Sediment Basins* is presented in Table B18.

Table B18 – Recommended discharge standard for de-watering operations

| Site conditions | Discharge water quality standard |
|---|--|
| Desired discharge water quality of free draining <i>Sediment Basins</i> (e.g. free draining Type C basins) | Take all reasonable and practicable measures to operate and/or modify the basin to achieve a 90 percentile total suspended solids concentration not exceeding 50 mg/L. |
| Post-storm de-watering of <i>Sediment Basins</i> (e.g. Type F and D basins, and Type C basins operating as wet-basins). | 90 percentile total suspended solids (TSS) concentration not exceeding 50 mg/L. |

Discussion:

All commercial flocculants should initially be applied in accordance with site-specific soil investigations, or otherwise in accordance with the manufacturer's specifications if site-specific testing has not occurred. The flocculating agent and basin performance must then be monitored for at least the first 2 storm events to determine if adjustment to the application rate, application method, or basin operation is required.

When choosing a flocculating agent, it is important to note that (Landcom, 2004):

- the trivalent positive aluminium (Al^{3+}) ion present in alum is 2,000 times more effective than the monovalent sodium (Na^{1+}) ion present in salt;
- the bivalent position calcium (Ca^{2+}) ion present in gypsum is only 50 times more effective than sodium.

In all cases, if a flocculant is used, chemical analysis of the basin effluent must be carried out to ensure no harmful residual levels of the flocculant remain within the effluent. Regulatory authorities may exclude this requirement for selected flocculants.

Flocculating agents must be spread evenly over the entire pond surface or otherwise incorporated uniformly throughout the settling pond. In some cases this may require the flocculant to be pre-mixed into a slurry, then sprayed over the water surface. In other cases the flocculant may be incorporated by automatic dosing systems.

Extreme care must be taken with the choice of flocculating agent, its application to ensure protection of receiving waters and their ecology.

Unless otherwise reported by a scientific study, the pH of the flocculated water must be in the range 6.5 to 8.5 prior to discharge. If this is not achieved, pH adjustment may be necessary (e.g. dosing with lime to raise pH, or citric acid to lower the pH).

Whenever possible, water samples from the settled *Sediment Basin* must be tested in a laboratory before discharge to prove that the suspended solid content is below recommended level. It is strongly recommended that sufficient water testing be completed to enable a site-specific calibration between suspended solids concentrations (mg/L) and NTU turbidity readings. This would allow utilisation of the turbidity meters to determine when water quality reaches 50 mg/L.

In the absence of a site-specific relationship, Table B19 is presented as an alternative NTU-based water quality standard for *Sediment Basins*.

Table B19 – Alternative discharge standard for de-watering operations

| Site conditions | Discharge water quality standard |
|---|---|
| Desired discharge water quality of free draining <i>Sediment Basins</i> (e.g. free draining Type C basins) | Take all reasonable and practicable measures to operate and/or modify the basin to achieve a 90 percentile Nephelometric Turbidity Units (NTU) reading not exceeding 100, and 50 percentile NTU reading not exceeding 60. |
| Post-storm de-watering of <i>Sediment Basins</i> (e.g. Type F and D basins, and Type C basins operating as wet-basins). | 90 percentile Nephelometric Turbidity Units (NTU) reading not exceeding 100, and 50 percentile NTU reading not exceeding 60. |

If basin operation is managed through the use of a specified or determined NTU reading, then water samples must still be taken daily during de-watering operations to determine the total suspended solids (TSS) concentration. Both the TSS and NTU values must be recorded and reported as appropriate.

The final application rate must be sufficiently high to permit sediment flocculation and pond discharge within two to four days from the conclusion of each storm event, whilst maintaining other required water quality criteria such as pH.

(a) Gypsum

Gypsum is often considered the least ecologically threatening flocculant; however, it is also one of the least effective flocculants and can be difficult to apply in a manner that will allow the flocculant to work effectively. It should be noted that if the application of gypsum regularly fails to achieve adequate settlement of the sediment, then the overall threat to receiving water may be significantly greater than if one of the more potentially threatening, but more effective, flocculants were used.

In circumstances where high intensity storms are likely, it is recommended that gypsum dosage rates be increased to 70 kg per 100 m³. Depending on the clay mineralogy, this can achieve flocculation within 24-hours, allowing discharge within 2-days from the conclusion of a storm.

Technical Note B5 – Gypsum dosing

Procedure for the manual dosing of gypsum (developed from Landcom, 2004):

1. Place required gypsum quantity (say 32kg/100m³ of water) in an approximately 50 L drum perforated with 25 mm holes at 150 mm spacing.
2. Suspend the screened, recirculating pump intake into the drum.
3. Lift the drum into the basin such that basin water can enter and circulate through the drum.
4. Using the pump, spray the gypsum-rich solution evenly over the surface of the basin until the gypsum is fully removed from the drum. The pump outlet must spray the mixture over a wide area rather than just discharging as a confined “jet”.
5. Alternatively, if two pumps are available, use the two pumps to circulate basin water first to the on-shore tank, and then from the tank over the surface of the basin. A large mixing tank will usually be required.

(b) Alum

The use of alum (aluminium sulphate) as a flocculant is only recommended when it is used under controlled circumstances and by users who are aware of the potential downstream risks to the environment. Landcom (2004) reports that the residual alum concentration remaining in the basin effluent should not exceed the ANZECC (2000) freshwater quality “trigger value” of 0.055 mg/L for aluminium at pH levels above 6.5. Water pH levels lower than 5.5 will result in toxic concentrations of soluble aluminium, which can kill fish and other aquatic life.

Alum flocculation of *Sediment Basins* should not be used when working with highly acidic soils (pH < 5) or in situations where the effluent might flow to waters surrounded by potential acid sulfate soils.

(c) Polyelectrolytes

Excessive dosing with polyelectrolytes can result in the release of materials that can kill fish and other aquatic life and reduce the effectiveness of the flocculent.

Guidelines on the application of Polyaluminium Chloride (PAC) can be found in Appendix E of Landcom (2004), or the Auckland Regional Council’s guidelines/website.

(d) Flocculation within saline waters

Clay particles carry a negative electro-magnetic charge on their surface. This negative charge can cause mutual repulsion of the particles when immersed in fresh water. Depending on the strength of this negative charge, the mutual repulsion can dominate over gravitational forces resulting in a permanent suspension (dispersion) of the clay particles.

In saline water, the negative charge on the surface of clay particles is balanced by the abundant sodium and other positively charged ions allowing clay particles to collide, coalesce into flocs and settle.

B3 Basin construction and maintenance

Appropriate construction, operation and maintenance of *Sediment Basins* is a critical component of construction site management and environmental protection.

A default specification for the construction of *Sediment Basins* is provided below.

Attached to the end of this section is an example “*Certification of Basin Construction*” form. This, or an equivalent form, should be submitted to the relevant regulatory authority for each *Sediment Basin* constructed. Regulatory authorities are encouraged to require the submission of such forms, as well as *As-constructed Plans*, as mandatory for all *Sediment Basins*.

Default specifications for *Sediment Basin* construction:

Materials

- Earth fill: clean soil with Emerson Class 2(1), 3, 4, or 5, and free of roots, woody vegetation, rocks and other unsuitable material. Soil with Emerson Class 4 and 5 may not be suitable depending on particle size distribution and degree of dispersion. Class 2(1) should only be used upon recommendation from geotechnical specialist. *[Alternatively, set a standard based on exchangeable sodium percentage – seek expert advice.]*
- Riser pipe: minimum 250 mm diameter.
- Spillway rock: hard, angular, durable, weather resistant and evenly graded rock with 50% by weight larger than the specified nominal (d50) rock size. Large rock should dominate, with sufficient small rock to fill the voids between the larger rock. The diameter of the largest rock size should be no larger than 1.5 times the nominal rock size. The specific gravity should be at least 2.5.
- Geotextile fabric: heavy-duty, needle-punched, non-woven filter cloth, minimum ‘bidim’ A24 or equivalent.

Construction

1. Notwithstanding any description contained within the approved plans or specifications, the Contractor shall be responsible for satisfying themselves as to the nature and extent of the specified works and the physical and legal conditions under which the works will be carried out. This shall include means of access, extent of clearing, nature of material to be excavated, type and size of mechanical plant required, location and suitability of water supply for construction and testing purposes, and any other like matters affecting the construction of the works.
2. Refer to approved plans for location, dimensions, and construction details. If there are questions or problems with the location, dimensions, or method of installation, contact the engineer or responsible on-site officer for assistance.
3. Before starting any clearing or construction, ensure all the necessary materials and components are on the site to avoid delays in completing the pond once works begin.
4. Install required short-term sediment control measures downstream of the proposed earthworks to control sediment runoff during construction of the basin.
5. The area to be covered by the embankment, borrow pits and incidental works, together with an area extending beyond the limits of each for a distance not exceeding five (5) metres all around must be cleared of all trees, scrub, stumps,

roots, dead timber and rubbish and disposed of in a suitable manner. Delay clearing the main pond area until the embankment is complete. [*modify as necessary to limit total area of disturbance and any damage to protected vegetation*]

6. Ensure all holes made by grubbing within the embankment footprint are filled with sound material, adequately compacted, and finished flush with the natural surface.

Cut-off trench:

7. Before construction of the cut-off trench or any ancillary works within the embankment footprint, all grass growth and topsoil must be removed from the area to be occupied by the embankment and must be deposited clear of this area and reserved for topdressing the completing the embankment.
8. Excavate a cut-off trench along the centre line of the earth fill embankment. Cut the trench to stable soil material, but in no case make it less than 600 mm deep. The cut-off trench must extend into both abutments to at least the elevation of the riser pipe crest. Make the minimum bottom width wide enough to permit operation of excavation and compaction equipment, but in no case less than 600 mm. Make the side slopes of the trench no steeper than 1:1 (H:V).
9. Ensure all water, loose soil, and rock are removed from the trench before backfilling commences. The cut-off trench must be backfilled with selected earth-fill of the type specified for the embankment, and this soil must have a moisture content and degree of compaction the same as that specified for the selected core zone.
10. Material excavated from the cut-off trench may be used in construction of the embankment provided it is suitable and it is placed in the correct zone according to its classification.

Embankment:

11. Scarify areas on which fill is to be placed before placing the fill.
12. Ensure all fill material used to form the embankment meets the specifications certified by a soil scientist or geotechnical specialist.
13. The fill material must contain sufficient moisture so it can be formed by hand into a ball without crumbling. If water can be squeezed out of the ball, it is too wet for proper compaction. Place fill material in 150 to 250 mm continuous layers over the entire length of the fill area and then compact before placement of further fill.
14. Place riser pipe outlet system, if specified, in appropriate sequence with the embankment filling. Refer to specifications supplied below.
15. Unless otherwise specified on the approved plans, compact the soil at about 1% to 2% wet of optimum and to 95% modified or 100% standard compaction.
16. Where both dispersive and non-dispersive classified earth-fill materials are available, non-dispersive earth-fill must be used in the core zone. The remaining classified earth-fill materials must only be used as directed by [*insert title*].
17. Where specified, construct the embankment to an elevation 10% higher than the design height to allow for settling; otherwise finished dimensions of the embankment after spreading of topsoil must conform to the drawing with a tolerance of 75 mm from the specified dimensions.
18. Ensure debris and other unsuitable building waste is not placed within the earth embankment.
19. After completion of the embankment all loose uncompacted earth-fill material on the upstream and downstream batter must be removed prior to spreading of topsoil.
20. Topsoil and revegetate/stabilised all exposed earth as directed within the approved plans.

Spillway construction:

21. The spillway must be excavated as shown on the plans, and the excavated material if classified as suitable, must be used in the embankment, and if not suitable it must be disposed of into spoil heaps.
22. Ensure excavated dimensions allow adequate boxing-out such that the specified elevations, grades, chute width, and entrance and exit slopes for the emergency spillway will be achieved after placement of the rock or other scour protection measures as specified in the plans.
23. Place specified scour protection measures on the emergency spillway. Ensure the finished grade blends with the surrounding area to allow a smooth flow transition from spillway to downstream channel.
24. If a synthetic filter fabric underlay is specified, place the filter fabric directly on the prepared foundation. If more than 1 sheet of filter fabric is required, overlap the edges by at least 300 mm and place anchor pins at minimum 1 m spacing along the overlap. Bury the upstream end of the fabric a minimum 300 mm below ground and where necessary, bury the lower end of the fabric or overlap a minimum 300 mm over the next downstream section as required. Ensure the filter fabric extends at least 1000 mm upstream of the spillway crest.
25. Take care not to damage the fabric during or after placement. If damage occurs, remove the rock and repair the sheet by adding another layer of fabric with a minimum overlap of 300 mm around the damaged area. If extensive damage is suspected, remove and replace the entire sheet.
26. Where large rock is used, or machine placement is difficult, a minimum 100 mm layer of fine gravel, aggregate, or sand may be needed to protect the fabric.
27. Placement of rock should follow immediately after placement of the filter fabric. Place rock so that it forms a dense, well-graded mass of rock with a minimum of voids. The desired distribution of rock throughout the mass may be obtained by selective loading at the quarry and controlled dumping during final placement.
28. The finished slope should be free of pockets of small rock or clusters of large rocks. Hand placing may be necessary to achieve the proper distribution of rock sizes to produce a relatively smooth, uniform surface. The finished grade of the rock should blend with the surrounding area. No overfall or protrusion of rock should be apparent.
29. Ensure that the final arrangement of the spillway crest will not promote excessive flow through the rock such that the water can be retained within the settling basin at an elevation no less than 50 mm above or below the nominated spillway crest elevation.

Establishment of settling pond:

30. The area to be covered by the stored water outside the limits of the borrow pits must be cleared of all scrub and rubbish. Trees must be cut down stump high and removed from the immediate vicinity of the work.
31. Establish all required inflow chutes and inlet baffles, if specified, to enable water to discharge into the basin in a manner that will not cause soil erosion or the re-suspension of settled sediment.
32. Install a sediment storage level marker post with a cross member set just below the top of the sediment storage zone (as specified on the approved plans). Use at least a 75 mm wide post firmly set into the basin floor.
33. If specified, install internal settling pond baffles. Ensure the crest of these baffles is set level with, or just below, the elevation of the emergency spillway crest.

34. Install all appropriate measures to minimise safety risk to on-site personnel and the public caused by the presence of the settling pond. Avoid steep, smooth internal slopes. Appropriately fence the settling pond and post warning signs if unsupervised public access is likely or there is considered to be an unacceptable risk to the public.

Additional requirements for Riser Pipe Outlet Structure (Dry Basins):

1. Drill de-watering holes in the riser as specified on the plan.
2. Excavate anti-flotation pit.
3. Securely attach the riser to the conduit or conduit stub to make a watertight structural connection. Secure all connections between conduit sections by approved watertight assemblies.
4. Attach the anti-seep collars to the conduit as shown on the approved plan, or otherwise as specified.
5. Place the conduit and riser on a firm, smooth foundation of impervious soil. Do not use pervious material such as sand, gravel, or crushed rock as backfill around the conduit or anti-seep collars.
6. Place fill material around the conduit in 100 mm layers and compact around the pipe to at least the same density as the adjacent embankment. Ensure appropriate care is taken not to raise the pipe from firm contact with its foundation when compacting under the pipe haunches.
7. Place a minimum depth of 600 mm of lightly compacted backfill over the conduit before crossing it with construction equipment.
8. Anchor the riser in place by concrete or other satisfactory means to prevent flotation. Ensure the anti-flotation mass is at least 110% of water mass displaced by the riser pipe outlet system, including the volume displaced by the anti-flotation weight.
9. In no case should the conduit be installed by cutting a trench through the dam after the embankment is completed.
10. Attach anti-vortex device and trash guard to riser and as required (refer to specifications shown on the approved plan).

Maintenance of Sediment Basin

1. Inspect the sediment basin during the following periods:
 - (i) During construction to determine whether machinery, falling trees, or construction activity has damaged any components of the sediment basin. If damage has occurred, repair it.
 - (ii) After each runoff event. Inspect the erosion damage at flow entry and exit points. If damage has occurred, make the necessary repairs.
 - (iii) At least weekly during the nominated wet season (if any) otherwise at least fortnightly.
 - (iv) Prior to, and immediately after, periods of “stop work” or site “shutdown”.
2. Clean out accumulated sediment when it reaches the marker board/post, and restore the original storage volume. Place sediment in a disposal area or, if appropriate, mix with dry soil on the site.
3. Do not dispose of sediment in a manner that will create an erosion or pollution hazard.
4. Check all visible pipe connections for leaks, and repair as necessary.

5. Check fill material in the dam for excessive settlement, slumping of the slopes or piping between the conduit and the embankment; make all necessary repairs.
6. Remove all trash and other debris from the basin and riser.
7. Submerged inflow pipes must be inspected and de-silted (as required) after each inflow event.

Removal of Sediment Basin

1. When grading and construction in the drainage area above a temporary sediment basin is completed and the disturbed areas are adequately stabilised, the basin must be removed or otherwise incorporated into the permanent stormwater drainage system. In either case, sediment should be cleared and properly disposed of and the basin area stabilised.
2. Before starting any maintenance work on the basin or spillway, install all necessary short-term sediment control measures downstream of the sediment basin.
3. All water and sediment must be removed from the basin prior to the dam's removal. Dispose of sediment and water in a manner that will not create an erosion or pollution hazard.
4. Bring the disturbed area to a proper grade, then smooth, compact, and stabilise and/or revegetate as required to establish a stable land surface.

Certification of Sediment Basin Construction

BASIN IDENTIFICATION CODE/NUMBER:

LOCATION:

Legend: OK Not OK N/A Not applicable

Construction:

| Item | Consideration | Assessment |
|------|---|------------|
| 1 | Sediment basin located in accordance with approved plans. | |
| 2 | Embankment material compacted in accordance with specifications. | |
| 3 | Critical basin and spillway dimensions and elevations confirmed by as-constructed survey. | |
| 4 | Required freeboard adjacent embankments and spillway confirmed by as-constructed survey. | |
| 5 | Placement of rock on chute and upstream face of spillway in accordance with design details and standards. | |
| 6 | Placement of rock within energy dissipation zone downstream of spillway in accordance with design details and standard. | |
| 7 | All other sediment basin requirements in accordance with design details and standards. | |
| 8 | As-constructed plan prepared for basin and spillway. | |

INSPECTION OFFICER **DATE**

SIGNATURE

Geotechnical:

| Item | Consideration | Assessment |
|------|--|------------|
| 9 | Suitable material used to form all embankments. | |
| 10 | Appropriate compaction achieved in embankment construction (if observed). | |
| 11 | No foreseeable concerns regarding stability or construction of the basin and spillway. | |

INSPECTION OFFICER **DATE**

SIGNATURE

B4 References

ANCOLD 2000a, *Guidelines on Selection of Acceptable Flood Capacity for Dams*. Australian National Committee on Large Dams Inc.

ANCOLD 2000b, *Guidelines on Assessment of the Consequences of Dam Failure*. Australian National Committee on Large Dams Inc.

Auckland Regional Council 2008, *Chemical treatment guideline*, Auckland Regional Council, viewed September 2008, <<http://www.arc.govt.nz/>>.

Brisbane City Council 2001, *Sediment Basin Design, Construction and Maintenance Guidelines*. Brisbane City Council, Brisbane.

Department of the Army 1984, *Shore Protection Manual*. Coastal Engineering Research Center, Department of the Army, US Army Corp of Engineers, Washington, DC, USA.

Fifield, J.S. 2001, *Designing for Effective Sediment and Erosion Control on Construction Sites*. Forester Communications, California. ISBN 0-9707687-0-2.

Freeman, G. and Howells, L. 1995, *Saline Flocculation in Stormwater Quality Management*. Proceedings of 3rd Annual Conference on Soil and Water Management for urban Development, 12-15 September 1995. International Erosion Control Association of Australasia, Sydney.

Landcom 2004, *Managing Urban Stormwater: Soils and Construction - Volume-1*. Landcom, New South Wales Government, ISBN 0-9752030-3-7.

Ritchie, J.A. 1963, *Earthwork Tunnelling and the Application of Soil Testing Procedures*. Journal of the Soil Conservation Service of NSW, 19: 111-129.

USDA 1975, *Standards and Specifications for Soil Erosion and Sediment Control in Developing Areas*. United States Department of Agriculture, Soil Conservation Service, College Park, Maryland, USA.

Appendix C

Soils and revegetation

This appendix is provided as a guideline only and is not intended to replace the knowledge and expertise of recognised soils and revegetation specialists. The information is specifically targeted at engineers and construction supervisors, not soil scientists and revegetation specialists. Though not intended to be prescriptive, regulatory authorities may require compliance with aspects of this appendix.

This appendix does not provide sufficient information to allow inexperienced personnel to adequately assess soil conditions or design a site revegetation plan. Consultation with experienced soil and revegetation specialists is always strongly recommended unless unwarranted by the relatively small size, cost and impact of the project.

Explanatory Notes (identified by the tag: Exp-CXX are attached to the end of this appendix) provide additional information on specific topics.

C1 Introduction

A continuous and healthy coverage of low-growing ground cover vegetation can be one of the most effective forms of long-term erosion control. Vegetation increases the surface roughness, slows stormwater runoff, protects the soil against raindrop impact, helps to interlock soil clumps, improves the soil's infiltration capacity, and reduces evaporation losses from the underlying soil.

Vegetation can provide a wide variety of benefits, but as a form of erosion control, it is the establishment of a well-anchored cover in contact with the soil that provides the greatest benefit. Ideally, plants should be:

- native to the area (i.e. non weed species, and of local provenance);
- appropriate to the position in the landscape where they are to be planted;
- have good soil binding attributes;
- successfully compete with weed species; and
- provide the required short and long-term erosion protection through either living or discarded (mulch) organic matter.

It is noted that the provision of plant species with local provenance is often possible for trees and shrubs, but for grasses, the supply of seed for native species is sometimes limited, often of poor quality, and typically relatively slow to establish. It is also common for existing grass vegetation to be largely or wholly composed of introduced species, so each situation should be assessed separately.

It should be appreciated that site revegetation typically aims to meet a range of short- and long-term requirements, which may include erosion control and the provision of a variety of ecosystem services. Plants that meet the long-term objectives may not necessarily meet the short-term objectives, so revegetation strategies often need to allow for evolution through time.

C2 Planning site revegetation

When planning the revegetation of a site the best recommendation is to seek experienced advice through specialist landscape consultants, revegetation practitioners, local bushland care groups and government bodies. Selecting the most suitable plant species, establishment techniques, planting densities, fertiliser type, application rates, watering schedule and maintenance requirements, all require the guidance of experts.

A general understanding of the local topography, soil properties, and environmental conditions should be obtained before planning the site revegetation.

Early planning may be essential for the supply of some plant species (Exp-C01). It is also important to estimate approximate volumes of mulch and/or to confirm that such quantities can be supplied, or will be generated on the site during site clearing.

C3 Data collection

Appropriate soil data is necessary to determine if any soil modifications are required and to aid in the selection of the most suitable plant species (refer to Chapter 3 – *Site planning*).

When planning the revegetation it is important to collect essential site data, including (where appropriate):

- gradient of natural slopes typical for the area;
- site topography;
- local climate and rainfall data;
- current and future land use both within and adjacent to the site;
- flora survey of existing area and possible adjacent areas if disturbance has already occurred;
- soil data including texture, water holding capacity, structure, dispersion/slaking potential and nutrient content (refer to Section C9 for specific soil tests).

If any of the soil or topographic conditions outlined in Section C11 are identified on the site, then these locations along with the locations of environmentally sensitive areas should be highlighted within the soil map, revegetation plan and/or the Erosion and Sediment Control Plan (ESCP).

C4 Vegetative control of soil erosion

The various forms of soil erosion are described in Appendix M – *Erosion processes*. Each of these forms of soil erosion, whether initiated by wind, rain, or flowing water, are best controlled by different forms and/or combinations of vegetation. Table C1 outlines the types of vegetation most likely to be effective in the control of the various forms of soil erosion.

Table C1 – Plant selection for the control of soil erosion

| Erosion form | Primary vegetation | Secondary vegetation | Comments |
|-------------------------|---|-----------------------------|---|
| Water induced: | | | |
| Raindrop impact | Ground covers, grasses, and living or dead organic matter | Trees, shrubs | <ul style="list-style-type: none"> • Ground covers need to quickly cover the soil surface (i.e. not just straight, vertical shoots—which is often the early growth characteristic of many annuals). • Grasses include living, dormant and dead grasses. • Trees contribute by suppling leaf and bark litter (mulch). |
| Sheet erosion | Ground covers, grasses | | <ul style="list-style-type: none"> • Non-clumping, continuous ground cover is required. |
| Rill erosion | Ground covers, grasses | | <ul style="list-style-type: none"> • Non-clumping, continuous ground cover is required. |
| Gully erosion | Ground covers, vetiver grass | Trees, shrubs, woody debris | <ul style="list-style-type: none"> • Vetiver grass can be used to form a vegetative sediment barrier. • Trees and shrubs may be required for bank stability. |
| Tunnel erosion | | | <ul style="list-style-type: none"> • Stabilisation of soil and control of water pathways are of primary importance. • Avoid deep-rooted or short-lived plants on water impoundment embankments. |
| Wave erosion | Reeds | Mangroves | <ul style="list-style-type: none"> • Critical locations include coastlines, rivers, lakes and dams. • Mangroves can struggle to deal with significant wave attack. |
| Gravity induced: | | | |
| Mass movement | Trees, vetiver grass | Shrubs | <ul style="list-style-type: none"> • Use of deep-rooted plants is critical. |
| Wind induced: | | | |
| Wind erosion | Ground covers | Tree, shrubs, mulches | <ul style="list-style-type: none"> • Trees can form windbreaks. • Aided by increased surface roughness. |

Refer to Table I14 of Appendix I – *Instream works*, for guidance on the types of vegetation most likely to be effective in the control of the various forms of soil erosion along drainage channels and waterways.

C5 Plant selection

During plant selection the following issues should be considered:

1. Plant selection should focus on plant species suited to the local climate, topography and soil properties (Exp-C02).
2. Avoid the use of reinforced turf and other planting systems that result in the placement of synthetic materials into the ground where such material:
 - (i) may threaten wildlife and ground-dwelling or grazing animals;
 - (ii) reduce the potential for the future reuse of the topsoil (i.e. to strip, stockpile and reuse the existing topsoil); or
 - (iii) be damaged by grass fire resulting in reduced erosion control.
3. All plants should be suitably drought-resistant such that they will **not** require regular watering once established, unless such water can be reasonably supplied through water recycling or local rainwater/stormwater harvesting.
4. Ground covers in horizontal contact with the soil surface, such as creeping grasses and mulch, can be the most effective means of controlling raindrop impact erosion (Exp-C03).
5. A coverage of fast growing annual grasses should not be considered adequate short-term erosion protection unless supplemented with an adequate mulch cover that achieves the desired soil coverage (Exp-C04). Annuals, with their characteristic straight, vertical shoots may need to be mown/slashed before adequate percentage ground cover is achieved.
6. Deep-rooted plants, such as trees and shrubs, are the primary means of stabilising steep slopes; however, even on these slopes it is important to incorporate ground covers to help control raindrop impact erosion.
7. Desirable characteristics for grasses and ground cover revegetation species include:
 - plants with a fibrous root system (Exp-C05);
 - plants that spread through rhizomes and/or stolons (Exp-C06);
 - plants that primarily grow horizontally, rather than “upright” clumping plants (Exp-C07);
 - leguminous plants (Exp-C08);
 - non-invasive plants (Exp-C09);
 - plants that represent cost-effective establishment and maintenance.
8. The types of plants selected, including their root system characteristics, can be a critical aspect of the plant’s ability to control certain types of soil erosion and hydraulic stress (Exp-C10).
9. **Extreme care should always be taken when introducing any new vegetation near a watercourse, bushland reserve or agricultural area.** This especially applies to the introduction of grasses, vines or other plants that may be classified as agricultural or environmental weeds. Certain grass species can be a problem to agricultural lands and along creeks and drainage channels. It is important to consult with local environmental groups and/or government departments about the potential for species to become agricultural or environmental weeds.
10. Avoid clumping or tussock forming grasses as these can increase water turbulence causing scouring between the clumps. Observations of the local landscape by a trained eye is still one of the best ways of determining the suitability of plant species.

C6 Vegetation clearing

Vegetation clearing is a necessary part of most construction activities. This clearing needs to be conducted in a manner that minimises damage to any retained vegetation including protected trees, buffer zones and native vegetation corridors. Best practice (2008) site management includes appropriate consideration of the following:

1. Preparation of a *Vegetation Management Plan* (VMP) prior to commencement of any vegetation clearing.
2. Site clearing should not occur unless preceded by the installation of all necessary drainage and sediment control measures. The exception being any site clearing necessary to allow installation of these control measures.
3. Selective clearing should aim to retain a variety of species and plants of varying ages with an emphasis on healthy plants, plants with habitat value, and tree groups.
4. Partially hollow or even some dead trees often need to be saved for the habitat value the trees provide to local wildlife.
5. Disturbance to large bushland reserves should be done in a manner that avoids fragmentation, but retains the largest single bushland unit (Exp-C11).
6. Site clearing should be staged to minimise the extent and duration of soil exposure. Sequential clearing provides many advantages for erosion and sediment control, and can also improve the “natural” relocation of local wildlife.
7. If vegetation clearing must be carried out well in advance of earthworks, then this clearing should be limited to the removal of woody vegetation only. Wherever reasonable and practicable, the grubbing and the removal of any ground cover (mulch or vegetation) should not occur until immediately prior to earthworks occurring within a given stage of works.

The exception to above rule would be when construction works are carried out during an extended dry period when erosive rainfall and/or winds are unlikely to occur. In any case, the **intent** should be to minimise the duration that soils are exposed to the erosive effects of wind, rain or running water, without causing an unnecessary financial burden to the project.

8. Site clearing should not extend beyond that necessary to provide up to eight (8) weeks of site activity during those months when the expected rainfall erosivity is less than 100, six (6) if between 100 and 285, four (4) weeks if between 285 and 1500, and two (2) weeks if greater than 1500 (refer to Chapter 4 – *Design standards and technique selection*).

Alternatively, if monthly rainfall erosivity cannot be determined:

Site clearing should not extend beyond that necessary to provide up to eight (8) weeks of site activity during those months when the actual or average rainfall is less than 45mm, six (6) if between 45 and 100mm, four (4) weeks if between 100 and 225mm, and two (2) weeks if greater than 225mm.

9. Wherever reasonable and practicable, site clearing should be limited to 5m from the edge of proposed constructed works, 2m of essential construction traffic routes, and a total of 10m width for construction access. Protected vegetation must remain protected irrespective of the above recommendations.
10. Wherever reasonable and practicable, cleared vegetation should be mulched (e.g. by tub grinding) for use on the site as an erosion control aid and to satisfy landscaping requirements. The practice of selling/disposing of potential mulch early in the construction program, only to import mulch at a later date, must be avoided unless justified by sound landscaping practice.

C7 Vegetation management

When earthworks are carried out adjacent to existing vegetation there is the potential to cause long-term damage to the vegetation even though the works may not appear to have touched the plants or caused any short-term damage. Potential long-term problems may result from:

- exposure of, or damage to, the roots (Exp-C12);
- partial burial of the trunk causing collar rot;
- earth fill placed around established trees, thus increasing the burial of the surface root system resulting in reduce oxygen supply to the plant;
- alterations to the sub-surface flow of water passing by the root system.

Best practice (2008) vegetation management requires giving appropriate consideration to the following issues:

1. Seeking expert advice on the most appropriate means of protecting retained vegetation.
2. Preparation of a *Vegetation Management Plan (VMP)* prior to commencement of any on-site works.
3. Development of a *Vegetation Management Plan* to clarify how all retained vegetation will be protected during the construction phase, including the identification of required *Tree Protection Zones*.
4. Establishment of Tree Protection Zones around retained vegetation. Such zones being a minimum of 10 times the trunk diameter of the tree measured 1m from the ground, or the width of the tree canopy at its widest point, which ever is the greater distance.
5. Maintain fencing, barriers or other warning signs around Tree Protection Zones, Buffer Zones, protected vegetation and designated non-disturbance areas.
6. Ensuring that there is no encroachment of construction/building works into the Tree Protection Zones unless via *trenchless digging* or *directional boring* for the installation of services. No root in excess of 25mm diameter should be disturbed within this protection zone.
7. Minimising changes in ground elevation adjacent to retained vegetation. If land reshaping must occur adjacent to retained vegetation, then it must be performed in a manner that will not remove these plants off from essential soil moisture.
8. Ensure prompt implementation of the site's revegetation program.
9. Use of root barriers to allow the coexistence of trees and adjacent engineering structures.
10. Ensuring construction/building activities do not disturb or damage the root systems of retained vegetation.
11. Cutting roots with a water lance, or cutting the roots while they are underwater to minimise air intrusion into the roots.
12. Cutting tree roots in stages over a period of days to allow tree roots to repair and adapt.
13. Transplanting selected species—this is a high-risk procedure not suited to all species.

When preparing a management plan for the site revegetation activities the following should be considered:

- Revegetation is best carried out under qualified supervision.
- Preference should be given to digging equipment that does not excessively pulverise or compact the soil (Exp-C13). High-pressure water jets can be highly effective for opening holes for individual plants.
- Plants should be delivered to the site in covered vehicles or sheeted trucks.
- Plants should be inspected upon delivery. Unhealthy or damaged plants, or plants that have out-grown their pots, should be rejected. This will require the removal of some plants from their pots.
- Plants must be protected from sun, heat and drying-out during shipment, storage and during planting (Exp-C14).
- In environmentally sensitive areas, mulches may need to be totally weed-free, and in many instances, seed-free.
- In environmentally sensitive areas, construction and planting equipment may need to be washed clean before entering the site (Exp-C15).

C8 Soil preparation and management

Good soil preparation is the first step in site revegetation. It is important to remember that topsoil contains living matter and has biological, physical and chemical properties that can be damaged if inappropriately managed. Damage to the soil's biological and chemical properties will most likely occur through inappropriate stockpiling. The soil's physical properties may be damaged through excessive compaction, over-working the soil, or working the soil at the wrong moisture content.

Best practice (2008) soil management involves application of the following practices where appropriate:

1. Topsoil should be preserved for reuse on the site wherever possible. The practice of selling/disposing of stripped topsoil early in the construction program, only to import alternative topsoil at a later date, must be avoided unless justified by sound soil science.
2. Wherever reasonable and practicable, strip and stockpile topsoil immediately before bulk earthworks, and confine any soil disturbance to the immediate construction stage.
3. Topsoil should be stripped only while in a light moisture condition. If the soil is too dry, stripping it will pulverise the soil, if too wet and it may lead to clodding or hardsetting—particularly if the soil has a high silt or clay content. (Exp-C16).
4. To the maximum degree practicable, topsoils should not be mixed with subsoils during the stripping and stockpiling procedure, especially if the subsoils are dispersive.
5. Ideally the top 50mm of soil should be stockpiled separately and respread as the top layer. However, if the soil contains excessive weed seed, then this top 50 mm layer may need to be buried, or otherwise treated to prevent the spread of weeds.
6. If it is desirable to retain the seed content of the soil, then the stockpiling should consist of long low mounds no greater than 1 to 1.5m in height, otherwise, topsoil stockpiles should not exceed 3m in height (refer to Table 6.2, Section 6.11, Chapter 6 – *Site management*). Long-term stockpiles may need to be mulched or temporarily vegetated to prevent weed infestation.

7. Stripped topsoil should be used as soon as possible, and preferably not stockpiled for more than 12 months. Long-term stockpiling can degrade its biological and chemical qualities.
8. Maintain all stockpiles in a free draining condition to avoid long-term soil saturation.
9. All topsoil should be tested for fertility and adjusted (where necessary), even if the soil originated from the site.
10. Before respreading the topsoil, scarify the subsoil to break up any compacted or surface sealing and to enable keying of the two soils. For example:
 - on slopes less than about 3:1(H:V) scarify lightly compacted subsoil with a tined implement to a depth of 50 to 100mm, and heavily compacted subsoils to a minimum depth of 300mm, ensuring all ripping operations occur along the contour;
 - on banks steeper than about 3:1(H:V), chain or harrow to break any surface seal and fill any minor rills; alternatively, the surface can be track walked to promote the formation of cleat marks parallel to the contour.
11. When it is desirable to re-establish the entrapped seed content of the soil, the topsoil should be re-spread in the reverse sequence to its removal so that the original upper 50mm soil layer is returned to the surface.
12. Soil should be removed from stockpiles in a manner that avoids vehicles travelling over the stockpile.
13. Spread topsoil to a lightly compacted (i.e. firm) depth of about 40 to 60mm on lands where the slope exceeds 4:1(H:V) and 75 to 100mm on lesser slopes. Special techniques, including stair-stepping of subsoil surfaces, will be required when spreading topsoil on slopes steeper than 2:1.
14. Exposed subsoils should be covered as soon as practicable, especially if dispersive.
15. After spreading topsoil, ensure the surface is left in a scarified (roughened) condition to assist moisture infiltration and inhibit soil erosion.
16. When working adjacent to a waterway, avoid spreading topsoil at a significantly different “elevation” from where it originated.
17. Ensure all exposed subsoils are covered, especially if dispersive.
18. Prior to planting, cultivate any compacted or crusted topsoil surfaces (to a depth of 100mm, but not greater than the depth of topsoil).
19. Soil stockpile areas should be rehabilitated as soon as reasonable and practicable after the material has been removed.

C9 Soil testing

In simple terms, answers are required to the following questions:

- What soil testing is required?
- What are the desired soil properties for the site?
- How can the soil be adjusted to achieve these soil properties?

An understanding of the structural properties of soils is generally easy to obtain; however, what needs to be equally well understood is the relationship between the soil properties and the short- and long-term success of the site revegetation activities.

Soil sampling must be representative of the soil unit to be tested, and the final soil sample should be a composite of several samples taken from a land unit. A reference for soil testing is Rayment and Higginson (1992). Discussion on soil testing is provided in Chapter 3 – *Site planning*.

Soil properties usually fall into two main categories, physical properties and chemical properties. Routine **topsoil** analyses may include:

- Soil pH (water) and pH (CaCl₂)* (Exp-C17)
- Electrical conductivity (EC) (Exp-C18)
- Organic carbon, total nitrogen (N), nitrate*
- Exchangeable basic cations (Ca, Mg, K, Na)* (Exp-C19)
- Exchangeable acidic cations (Al)*
- Cation exchange capacity (CEC)* (Exp-C20)
- Plant available phosphorus (P) and potassium (K)*
- Trace elements (Cu, Zn, Mn, Fe, B)
- Sulfur
- Soil texture*

* Indicated essential soil tests.

Routine **subsoil** analyses may include:

- Soil pH (water) and pH (CaCl₂)*
- Electrical conductivity (EC)*
- Nitrate, and nitrogen*
- Exchangeable cations (Ca, Mg, K, Na, Al^{**})*
- Exchangeable sodium percentage (ESP)
- Cation exchange capacity (CEC)*
- Emerson dispersion number (if required by local design codes/procedures)
- Particle-size analysis and soil texture*
- Testing for potential or actual acid sulfate soils where appropriate

* Indicated essential soil tests.

** Exchangeable Aluminium is determined if the pH (CaCl₂) is ≤ 5.4

Soil pH must be reported with its relevant soil to extractor ratio e.g. 1:1, 1:2 or 1:5, and the extractor, e.g. water, sodium chloride or potassium chloride. **Hazelton & Murphy (1992, 2007) are useful publications for the interpretation of soil test results.**

Soil data, collected for the purpose of revegetation, should be analysed by a soil scientist or an agronomist/ecologist with soil science experience. Where practicable, imported topsoil should comply with the specifications of AS-4419.

C10 Soil adjustment

Soils should be adjusted with a combination of fertilisers and ameliorants to improve both the short- and long-term success of their revegetation. Fertilisers must be applied in accordance with manufacturer's guidelines, or site-specific specialist advice.

The soil testing report should, as a minimum, provide advice on the pH, nitrogen, organic matter, phosphorus, potassium and lime requirements for both the topsoil and subsoil. It is essential for the pH of the soil to be appropriately adjusted so that the essential nutrients that exist within the soil can be made available to the plant. Most plant nutrients are readily available in the pH range of 6.5 to 7.5, but locally adapted vegetation can grow successfully over a much wider pH range. In some instances, it may be more effective to select species to suit the local conditions rather than to alter the soil to suit some selected vegetation.

Tables C2 and C3 provide a brief summary of typical soil adjustments for common problematic soils.

Table C2 – Typical soil adjustments

| Problem | Soil amelioration |
|----------------|--|
| Sodic soils | <ul style="list-style-type: none"> The application of calcium (in the form of gypsum) at an application rate determined by soil testing (typically 10 to 25t/ha) |
| Salinity | <ul style="list-style-type: none"> Heavy application of organic matter (reduces evaporation and salt concentration at the soil surface) Cultivation or deep ripping (avoid ripping sodic-saline soils) Improved drainage to lower the water table (not suitable if soils are actual or potential acid sulfate soils) Deep ripping and gypsum application (deep ripping usually has only temporary effects but can still be helpful; there should be a specific reason or logic for doing it, e.g. targeting a restrictive layer) Irrigation to leach soluble salts from the root zone (always seek expert advice) |
| Acidity | <ul style="list-style-type: none"> Application of lime Application of dolomite, silicate rock dust or organic material |
| Alkalinity | <ul style="list-style-type: none"> Application of sulfur Application of ammonium or nitrate fertilisers, peat, ferrous sulfate or phosphoric acid |

Table C3 – Typical soil adjustments ^[1]

| Topsoil properties | Subsoil properties | Required soil adjustment |
|---------------------------|---------------------------|--|
| Acid | Acid | <ul style="list-style-type: none"> Add lime (Exp-C21) |
| Acid | Sodic (alkaline) | <ul style="list-style-type: none"> Add gypsum Add lime (Exp-C21) |
| Acid | Saline | <ul style="list-style-type: none"> Add lime (Exp-C21) Lower watertable |
| Neutral | Acidic | <ul style="list-style-type: none"> Add lime (Exp-C21) |
| Neutral | Sodic (alkaline) | <ul style="list-style-type: none"> Add gypsum |
| Neutral | Saline | <ul style="list-style-type: none"> Lower watertable |
| Alkaline | Sodic (alkaline) | <ul style="list-style-type: none"> Add gypsum Grow acidifying legumes ^[2] Incorporate organic matter/mulch into the soil |
| Sodic | Saline | <ul style="list-style-type: none"> Add gypsum Lower watertable |
| Saline & sodic | Saline & sodic | <ul style="list-style-type: none"> Add gypsum Control watertable |
| Sodic (alkaline) | Sodic (alkaline) | <ul style="list-style-type: none"> Add lots of gypsum |

Notes: [1] Developed from Glendinning (1999).

[2] This could be fairly slow process depending on how well the legumes fix nitrogen. It can also be hard to find legumes that grow well on soils with high pH right at the surface.

C11 Management of problem soils

The cause of problem soils typically falls into one of three categories, chemical, physical and biological.

- *Chemical problems* generally relate to either an excess, or lack of, a certain substance.
- *Physical problems* relate to its structure, texture, surface crusting, wet or dry strength of the soil, or its ability to infiltrate or retain water.
- *Biological problems* relate to diseases contained within the soil that may affect plant germination and growth.

Table C4 provides general discussion on the revegetation of various common problematic soils.

Table C4 – Design considerations for various problematic soils

| Soil type | Design considerations | Revegetation |
|------------------------------------|---|---|
| Dispersive (sodic) soils (Exp-C22) | <ul style="list-style-type: none"> • Dispersive soils are highly susceptible to deep, narrow, rilling (fluting) on slopes and drains. • High risk of tunnel erosion if water pathways are not managed properly. • Wherever practicable, dispersive soils must be treated or completely buried under a layer of non-dispersive soil before placing any scour control measures, including vegetation. | <ul style="list-style-type: none"> • Avoid the direct revegetation of dispersive soil. Where this is unavoidable, treat (e.g. add gypsum) prior to revegetation. • Do not rely solely on the root system of plants to control erosion within dispersive soils. • Critical erosion areas are steep slopes and changes of grade within drainage channels. |
| Non-cohesive, sandy soils | <ul style="list-style-type: none"> • Design of constructed slopes should be based on geotechnical advice, or existing stable slopes. • Batter slopes of 6:1 (H:V) or flatter are highly desirable in non-cohesive soils, with a maximum recommended slope of 4:1. | <ul style="list-style-type: none"> • Sandy soils are usually best stabilised with grasses and ground cover vegetation. • High, steep slopes (>4:1) should also be well anchored with deep-rooted plants (e.g. trees and shrubs). |
| Highly erodible clayey soils | <ul style="list-style-type: none"> • Long-term scour protection is likely to rely on the establishment of a good vegetative cover. | <ul style="list-style-type: none"> • Grasslands or open woodlands often work best. • Avoid establishing a high density of trees that will eventually shade out ground cover vegetation. |
| Low fertility soils | <ul style="list-style-type: none"> • These soils are usually more erodible than fertile soils. • Consider rock protection if a suitable vegetative cover cannot be achieved. | <ul style="list-style-type: none"> • Revegetation may require a long maintenance period. • Soil fertility should be tested and adjusted before revegetation (as is the case for all soils). |
| Potential acid sulfate soils | <ul style="list-style-type: none"> • Avoid exposure of potential acid sulfate soils. Especially avoid the formation of open drains that intersect these soils. • Manage soils in accordance with State policies/guidelines. • Long-term erosion and scour holes should be prevented from occurring. | <ul style="list-style-type: none"> • Test soils located below 5m AHD before commencing excavations. • Treat exposed soils with agricultural lime. • Follow established guidelines for site rehabilitation and revegetation. |

A nutrient imbalance is possibly the most common cause of poor plant growth, and is possibly the easiest soil problem to overcome. Eighteen chemical elements are known to be essential for plant growth. Problems can occur if just one of these chemicals is in short supply. If a plant cannot get enough of an essential element, it is said to be deficient in that element.

A plant may be deficient in an element even though the soil contains adequate supplies of this element. This is because the *soil conditions* may not make that element readily available to the plant. Often a pH change is required to make an element more soluble and thus more readily available.

Soils with a poor structure may show one or more of the following features:

- a hard, impervious surface soil, or surface crust;
- surface sealing and runoff after light rain, especially if runoff is milky;
- a powder of individual particles and very small peds;
- few surface pores to allow water to enter the soil profile;
- few drainage pores to conduct water through the soil;
- “spewy” topsoils, when saturated;
- large clods and soil crusts when cultivated;
- clods and aggregates resistant to breakdown by cultivation or rain;
- failed revegetation.

If any of these problems are evident on the site, then the soil report will need to provide recommendations on suitable soil adjustments (for example, extra organic matter may be needed to improve the soil and allow germination).

C12 Planting requirements for special locations

Special planting requirements may be required in the following circumstances.

- acid sulfate soils
- arid and semi-arid land (also see Section C15) (Exp-C23)
- dispersive (also see Section C14) (Exp-C24)
- exposed sites (Exp-C25)
- extremely acid soils
- extremely alkaline soils
- hardsetting and surface sealing soils (Exp-C26)
- saline soils (Exp-C27)
- sandy soils (Exp-C28)
- sodic soils (also see Section C14) (Exp-C24)
- soils with inadequate available water capacity (Exp-C29)
- steep slopes (Exp-C30)
- waterlogged soils (Exp-C31)
- water-repellent soils (Exp-C32)
- water storage embankments (Exp-C33)

C13 Planting procedures

Revegetation contracts usually require incorporation of one or more of the following features which are discussed in more detail in Chapter 7 – *Site inspection*.

- Specifications
- Hold Points
- Inspection Test Plan (ITP)
- Non-conformance reports (NCR)
- Payments/Retentions

Best practice (2008) site management involves giving appropriate consideration to the following:

- (i) Prior to sowing seed, confirm that the soil surface and subsoil (to a depth of 300 mm) is not excessively compact (Exp-C34).
- (ii) Random samples of purchased seed should be collected and inspected (Exp-C35).
- (iii) Where appropriate, selected examples of seed and seedlings should also be retained as control samples (Exp-C36).
- (iv) Trees and shrubs that are to be planted in the open should consist of sun-hardened stock.
- (v) Inspect the rootball of all trees once removed from the pot. Any roots circling around the *outside* of the rootball must be either cut through or pulled from the rootball. Any roots circling around the *base* of the rootball should be removed (Exp-C37). Reject any plant with excessive root curling, especially when older and thicker roots are curling.
- (vi) Where appropriate, randomly placed sample trays should be used to monitor seed application rates (Exp-C38).
- (vii) All plants should be watered after initial placement (Exp-C39). Watering by trucks is generally limited to areas less than 5000m² depending on location and time of year. Larger areas generally require the use of a temporary irrigation system.
- (viii) The timing and frequency of watering following seeding can be more important than the volume of water, especially during initial establishment (Exp-C40).
- (ix) Application of a mulch layer around the plant is strongly recommended to control moisture loss (Exp-C41).
- (x) Only low-pressure watering sprays should be used because high-pressure jets can seal off the soil surface and wash away the seed and mulch cover.
- (xi) Avoid planting directly into subsoil, even if the original site consisted of exposed subsoil (Exp-C42).
- (xii) Rolling the seeded area may promote seed germination. The rolling action must leave the surface corrugated or indented rather than compacted. The roller weight should not exceed 90kg/m. Avoid rolling sloping ground where such action may increase surface runoff.
- (xiii) A light mulching cover should be applied to recently seeded areas (Exp-C43).
- (xiv) A heavy mulch cover should be applied around seedlings and on future garden beds (Exp-C44).
- (xv) Where appropriate, the mulch layer should be suitably anchored, especially if applied to slopes steeper than 4H:1V (Exp-C45). Mulch generated through

- either horizontal or tub grinder, **not** chipping, is likely to be more stable on sloping ground.
- (xvi) Prior to the application of a heavy mulch layer, advice should be obtained on the need for additional nitrogen fertiliser (Exp-C46).
 - (xvii) Contract specification should detail both the initial “soil” coverage and the required vegetation coverage at a specific “time”, “construction stage”, or “point in contract” (Exp-C47).
 - (xviii) Inspection and Test Plans (ITPs) should be prepared for revegetation works in sensitive environments, or when the area of revegetation exceeds 1ha (Exp-C48). Refer to Chapter 7 – *Site inspection* for further discussion on ITPs.

Available access for planting equipment must be considered before selecting the desired planting procedures. The recommendations provided in Table C5 have been sourced from Department of Main Roads (2002).

Table C5 – Access requirements for revegetation treatments

| Planting Technique | Access requirements |
|---------------------------|--|
| Broadcast seeding | Requires access for vehicle (quad, RTV, or tractor) or for individuals to undertake hand seeding |
| Drill seeding | Requires access by 4WD tractor |
| Hydroseeding | Access by truck to within 100m of the treatment area |
| Hydromulching | Access by truck to within 100m of the treatment area |
| Hay/straw mulching | Access by truck to within 15m of the treatment area |
| Trash blanket | Access by truck and foot traffic to within 10m of the treatment area |
| Erosion control blankets | Foot traffic access required |
| Bonded fibre matrix | Access for tandem truck within 50m of treatment area |
| Planting | Foot traffic access required |
| Turfing | Requires access for truck or “bobcat” adjacent to treatment area |
| Reinforced turf | Requires access for truck or “bobcat” adjacent to treatment area |
| Willowing (Exp-G49) | Foot traffic access required |
| Stiff grass barriers | Foot traffic access required |

There are several basic methods used for the establishment of vegetation, including:

- Hand seeding and tube stock (Exp-C50)
- Drill seeding (Exp-C51)
- Broadcasting (Exp-C52)
- Sprigging (Exp-C53)
- Hydroseeding (Exp-C54)
- Hydromulching (Exp-C54)
- Bonded Fibre Matrix (BFM) (Exp-C54)
- Compost blankets (Exp-C54)
- Seed mats (Exp-C55)
- Turfing or sodding (Exp-C56)
- Trash blankets or brush matting (Exp-C57)

Table C6 outlines the general attributes of some of the grassing techniques.

Table C6 – Attributes of various grassing procedures ^[1]

| Grassing procedure | Attributes |
|--|---|
| (i) Hand seeding, drill seeding and hydroseeding | <ul style="list-style-type: none"> • High risk of erosion if applied directly to highly dispersive soils. • Heavy rain during the establishment period will likely cause erosion (rilling) of steep slopes. • Hydroseeding (without subsequent mulching) provides little or no protection of the soil surface during the vegetation establishment. |
| (ii) Grass seeding (as for (i) above) covered with <i>Erosion Control Blanket</i> | <ul style="list-style-type: none"> • Use of an <i>Erosion Control Blanket</i> should reduce soil erosion resulting from rainfall during vegetation establishment. • Use of a thick <i>Erosion Control Blanket</i> can be an effective means of controlling the germination weed seed within the underlying topsoil. A grass seed can be sprayed (<i>Hydromulch</i> or <i>Bonded Fibre Matrix</i>) onto the thick blanket (seek expert advice). • If the seeded soils are dispersive, then significant rilling can still occur during and after vegetation establishment. |
| (iii) Grass seeding (as for (i) above) covered with jute or coir <i>Erosion Control Mesh</i> | <ul style="list-style-type: none"> • Application of a light anionic bitumen emulsion over the <i>Erosion Control Mesh</i> should reduce water evaporation and the displacement of grass seed. • During periods of low rainfall (where water is not readily available), an annual grass may be established with only an initial watering. The established grass cover may be allowed to die-off leaving a well-anchored cover of dead grass. Permanent vegetation must be established once water or rainfall becomes available. |
| (iv) Straw mulching (machine or hand application) | <ul style="list-style-type: none"> • Very effective when water usage is critical. • Stability of the mulch on steep slopes depends on the choice and application rate of tackifier or other appropriate anchor. • If full coverage of the soil is achieved by the straw (best practice), then effective control of raindrop impact should be achieved. |
| (v) Hydromulch (including seed) | <ul style="list-style-type: none"> • Generally only suitable on low gradient slope (i.e. not batters) if moderate to heavy rainfall is expected during the plant establishment period. • <i>Hydromulches</i> generally require more watering to achieve successful plant establishment compared to <i>Straw Mulching</i>. • <i>Hydromulch</i> uses a wettable binder and thus is more susceptible to failure during moderate to heavy rainfall compared to <i>Erosion Control Blankets</i>, <i>Bonded Fibre Matrix</i>, and <i>Compost Blankets</i>. |
| (vi) Bonded Fibre Matrix (BFM) | <ul style="list-style-type: none"> • <i>Bonded Fibre Matrix</i> applications are thicker than <i>Hydromulching</i>. • <i>Bonded Fibre Matrix</i> normally incorporates a non-wettable binder allowing better performance if moderate to heavy rainfall or surface runoff occurs during the plant establishment period. |
| (vii) Seeded compost blanket | <ul style="list-style-type: none"> • Used successfully in the revegetation of steep slopes using grasses and/or other plant seed. • Particularly useful when slopes are too steep for the placement of topsoil, or when insufficient topsoil exists on the site. |
| (viii) Turfing | <ul style="list-style-type: none"> • Best used when a quick establishment period is required. • Turf placed in areas of concentrated flow needs to be pegged (wooden stakes) if flows are expected within the first two weeks. • A reliable water supply must be available if regular rainfall is not expected during the first few weeks of growth. |

Note: [1] List of grassing procedures is not comprehensive.

C14 Revegetation within dispersive soil regions

Revegetation within dispersive soil regions contains a number of challenges. Firstly there is the risk of soil erosion caused by rain falling during the revegetation period. Secondly there is the risk of failed revegetation due to various factors including insufficient water and displacement of plant seed by wind and rain. Thirdly there is the risk that successfully revegetated areas will be undermined by long-term rilling or gully erosion initiated downstream or down-slope of the revegetated area.

In some cases, poor revegetation practices can still achieve long-term stability if favourable weather conditions exist over the following years. On the other hand, even best practice revegetation procedures can fail if adverse weather conditions occur following initial planting. Consequently, the failure of site revegetation or the existence of soil erosion does **not** necessarily indicate that the project was poorly designed and/or managed. Similarly, a successful outcome does **not** necessarily indicate that best practice procedures were followed.

The factors that influence the probability of successful revegetation include:

- The quality of professional advice obtained prior to revegetation.
- Degree of soil testing and the interpretation of test results.
- The management (i.e. treatment and/or burial) of dispersive soils.
- The appropriate detailing of engineering works such as roads, embankments and drainage works, in relation to the underlying dispersive soils.
- Slope of the soil surface (Exp-C58).
- Weather conditions following initial planting.

C15 Revegetation of rural road works

The preferred choice of revegetation technique within rural areas depends on many factors including expected weather conditions and the availability of a cheap, reliable water supply. One of the biggest costs of site revegetation within arid and semi-arid areas can be the delivery of sufficient quantities of water needed to achieve the specified grass cover of newly formed works. It is important for revegetation programs to be appropriate for the local conditions.

It is also important to note that construction site erosion control does not necessarily have to incorporate vegetation. Erosion control can be a separate activity to site revegetation, or equally it can be closely linked to appropriately staged revegetation activities. Ultimately the choice of construction site erosion control measures and final site revegetation will depend on a variety of factors including project economics, environmental conditions, and social factors. Table C7 summarises the advantages and disadvantages of the various revegetation options.

Even during periods of extended dry weather it may still be beneficial to establish a temporary cover of annual grasses within newly formed table drains and on batters. If appropriate mulching or similar is applied, such grasses can be established with little more than initial watering. If follow-up rains do not occur, then of course these newly established grasses will likely die-off, but what is left behind is a well-anchored organic (mulch) layer suitable for controlling dust and the occasional rainfall event.

Alternatively, grass seed may be spread over the batters, cultivated into the soil, mulched and left unwatered. This seed remains dormant in the soil until normal seasonal rains arrive. It is important that the seed is cultivated into the soil to prevent it

from being removed by wind, ants and birds. Such an approach has inherent erosion risks that should be discussed with the asset owner prior to progressing down this path.

Table C7 – Revegetation options in rural areas

| Revegetation options | Advantages | Disadvantages |
|--|--|--|
| No seeding or planting. | <ul style="list-style-type: none"> • Low cost. • No water usage. | <ul style="list-style-type: none"> • Ongoing dust problems. • Short and long-term erosion problems. • Potential deep rilling of embankments and drains. • Very long establishment time for final vegetation. |
| Seeding, cultivation (to mix the seed into the soil), then <i>Straw Mulch</i> , but no watering. | <ul style="list-style-type: none"> • No water usage. • Soil is seeded ready for seasonal rains. • Mulch protects the soil from occasional isolated rainfall. | <ul style="list-style-type: none"> • Winds can readily remove any loose mulch before rains occur if the mulch is not anchored with a light bitumen spray or similar tackifier. |
| Seeding, cultivation (to mix the seed into the soil), then cover with a thin <i>Erosion Control Blanket</i> or <i>Mesh</i> , but no watering. OR Application of a <i>Bonded Fibre Matrix</i> , but no follow-up watering. | <ul style="list-style-type: none"> • No or little water usage. • Soil is seeded ready for seasonal rains. • <i>Erosion Control Blankets</i> or <i>Mesh</i> can protect the batters and drains from occasional, isolated rainfall. | <ul style="list-style-type: none"> • Winds can remove, displace, or damage <i>Erosion Control Blanket</i> unless appropriately anchored. |
| Seeding, cultivation (to mix the seed into the soil), then apply <i>Straw Mulch</i> , <i>Erosion Control Blankets</i> and/or <i>Mesh</i> , water once, then seal with a light anionic bitumen spray or similar. Note: Thin <i>Erosion Control Blankets</i> are used on the batters, while the <i>Erosion Control Mesh</i> is used along the invert of table drains. | <ul style="list-style-type: none"> • Low water usage. • Annual grasses quickly establish then die-off. The dead grass continues to act as a well-anchored mulch. This protects the soil from wind and occasional, isolated rainfall. Wind-blown grass seed from the surrounding fields is captured within the dead grass ready for seasonal rains. | <ul style="list-style-type: none"> • Some water usage is required to initially establish the short-term annual grasses. |
| Seeding, cultivation (to mix the seed into the soil), then <i>Straw Mulch</i> and continue watering until the grass is fully established. | <ul style="list-style-type: none"> • Good erosion control of earth batters. • <i>Erosion Control Mesh</i> may be required along the invert of table drains if the <i>Straw Mulch</i> is likely to be displaced. | <ul style="list-style-type: none"> • High cost. • High water usage. • Questionable use of water during times of drought. |
| Cover with seeded <i>Compost Blanket</i> , then water until the grass is fully established. | <ul style="list-style-type: none"> • Good erosion control of batters and low to medium velocity drainage channels. | <ul style="list-style-type: none"> • Very high cost. • Medium water usage. • Questionable use of water during times of drought. |

C16 Maintenance of revegetated areas

Revegetated areas should be maintained until the plants are self-sustaining.

Best practice (2008) maintenance of site revegetation includes the following:

- (i) Monitoring, particularly after rainfall events, and maintenance to ensure that the revegetation is controlling erosion and stabilising soil slopes as required.
- (ii) Where practicable, fill in, or level out, any rill erosion that occurs between plants. If excessive erosion occurs, then consider increasing the planting density, applying appropriate erosion control measures, or introducing alternative, non-clumping plant species.
- (iii) Periodic application of water is essential, especially in the first 7 days after establishment. Only low-pressure sprays should be used because high-pressure jets can wash away the seed and mulch cover.
- (iv) Apply additional seed and/or soil conditioning as required.
- (v) Control excessive vegetation through mowing, slashing, or the controlled use of biodegradable herbicides—special care and advice must be taken around waterways. Grass height should be maintained at a minimum 50mm strand length within high velocity drainage reserves, or 25 to 50mm within overland flow paths.
- (vi) Control weeds—especially within a 1m radius of immature trees—for 6 to 12 months for fast growing species, and 18 to 24 months for slower growing species (Exp-C59). Pre-emergent herbicides should be considered where high weed seed germination is expected (Exp-C60).
- (vii) Maintain or renew (as necessary) mulches two to three times a year.
- (viii) Check and maintain protective fencing.
- (ix) Re-firm plants loosened by wind-rock, livestock or wildlife.
- (x) Replace dead or severely retarded plants.
- (xi) Prune any plants with dead or diseased parts.
- (xii) Dispose of cleared vegetation through chipping or mulching for future revegetation works, by on-site burial, or suitable off-site disposal; cleared vegetation should not be burnt on the site or dumped near a watercourse.

C17 References

Dear, S.E., Moore, N.G., Dobos, S.K., Watling, K.M. and Ahern, C.R. 2002, *Queensland Acid Sulfate Soil Technical Manual – Soil Management Guidelines. Version 3.8*. Department of Natural Resources and Mines, Indooroopilly, Queensland.

Department of Main Roads, 2002. *Road Drainage Design Manual*. Queensland Department of Main Roads, Brisbane.

Glendinning, J.S. 1999, *Australian soil fertility manual*. Fertiliser Industry Federation of Australia, Inc. & CSIRO Publishing, Collingwood.

Handreck, K. 1993, *Gardening Down-Under – The handbook for Inquiring Gardeners*. CSIRO Publications, East Melbourne. ISBN 0 643 05511 8.

Hazelton, P.A., and Murphy, B.W., 2007, *Interpretation of Soil Test Results*, NSW Department Natural Resources, CSIRO Publishing, Sydney, NSW. ISBN 978-0-64309-225-9

Hazelton, P.A., and Murphy, B.W., 1992, *What Do All the Numbers Mean? – A guide for the Interpretation of Soil Test Results*, NSW Department of Conservation and Land Management, Sydney, NSW.

Houghton, P.D. and Charman, P.E.V. 1986, *Glossary of Terms used in Soil Conservation*. Soil Conservation Service of NSW, ISBN 0 7305 1525 7.

Hunt, J.S. 1992, *Urban Erosion and Sediment Control*. Revised edition, NSW Department of Conservation and Land Management. Sydney, NSW ISBN 0 7305 9876 4.

Rayment, G.E., and Higginson, F.R. 1992,. *Australian Laboratory Handbook of Soil and Water Chemical Methods*. Inkata Press, Melbourne and Sydney.

Explanatory Notes – Appendix C

Exp-C01 – Site planning

Some species may require up to 12 months advance notice prior to planting to allow collection of local seed, propagation and planting at the optimum time. In environmentally sensitive areas the provision of local provenance plants may also need to be organised up to 12 months prior to planting. This may require action to be taken prior to awarding the principal construction contract.

Approximate delivery times should be obtained on the proposed plant listing long before site works commence.

Exp-C02 – Plant selection

The use of endemic native species suited to the local climate, soils and topographic conditions will increase the probability of a successful planting scheme. Inspections of surrounding native forests and/or garden beds can provide an indication of suitable plant species.

Exp-C03 – Ground cover

In general, some degree of ground cover vegetation is usually desirable to help anchor the mulch layer and/or directly cover the soil surface.

As a general rule, when fully established, at least 70 to 80% of the soil surface should be covered with mulch, grasses or herbaceous plants in order to obtain adequate erosion control. At least 70% coverage is typically required in temperate climates and at least 80% coverage is required in tropical areas. The lateral root system should occupy more than 60% of the surface area.

Exp-C04 – Annual grasses

Annual grasses are fast growing, but these plants die within 1 season providing limited soil coverage after 6 to 8 months. Most annual grasses primarily grow vertically thus providing only minimal protection against raindrop impact. In tropical regions where rainfall intensity is high, or when revegetating clayey topsoils that are susceptible to causing highly turbid runoff, a mulch layer will be necessary to adequately control soil erosion.

When viewed obliquely from a distance, annual grasses can appear as a thick, green, and complete vegetative coverage; however, as with any surface cover, annual grasses must be inspected by looking straight down on the soil surface (plan view). Mowing the grass (without collection of the cut grass) can help to improve the effective soil coverage.

Annual grasses, however, can quickly establish a root system that protects the soil against minor overland flows. These grasses can also provide effective stabilisation of the mulch layer against disturbance by wind and water, while the mulch layer protects the soil surface against raindrop impact.

Exp-C05 – Fibrous root systems

Grasses with a fibrous root system typically provide the greatest ability to control soil erosion caused by raindrop impact and high-velocity surface flow. A fibrous root system can also help to break up minor surface compaction resulting from past construction activities.

Exp-C06 – Rhizome and stolons

The rapid spread of rhizome (below ground) and stolon (above ground) stems allows adventitious roots to grow from these stems producing another plant, and thus a more homogeneous vegetative coverage of the soil. Many grasses and legumes spread through either or both rhizome and stolon stems. These plants provide quick soil coverage with a high root mass to improve soil-holding ability.

Stoloniferous grasses provide a better ground cover and erosion control than upright, tussock grasses. Stolons are the horizontal stems used by some grasses to spread out from a central clump. A ground cover of stoloniferous grass can significantly increase surface roughness during low flow rates, thus helping to maintain “sheet” flow conditions, reduce flow velocity and reduce erosion potential.

Tussock (clumping) grasses with fibrous root systems can concentrate shallow flows into rills, accelerating both flow velocity and the erosion process. This does not mean that all tussock grasses should be avoided.

Exp-C07 – Grasses

To protect soil against raindrop impact it is important for the plant mass (alive or dead) to cover the soil surface. Unfortunately, many fast-growing annual grasses primarily grow vertically. If such plant species are used for temporary revegetation, it is usually necessary to lightly mulch the area to adequately control raindrop impact, especially during the early growing phase. Mowing these annual grasses can help to improve the soil cover provided the cut grass is not blown or washed from the soil surface.

Tussocky ground covers and grasses with fibrous root systems may also **increase** the erosion potential of flowing water by increasing the local flow velocity around individual plants.

Exp-C08 – Legumes

Leguminous plants are useful when revegetating low-fertility soils because these plants represent a sustainable source of nitrogen for the soil.

In order to make this new nitrogen readily available to new plants, these leguminous plants may need to be ploughed into the soil before application of the permanent revegetation (seek expert advice on case-by-case basis).

Exp-C09 – Invasive grasses

Temporary revegetation often requires the use of non-invasive, or short-lived plant species to avoid the plants invading adjacent vegetation or critical habitats. Sterile hybrid species are generally preferred.

For example, *Kikuyu* and *Rhodes* grass should **not** be used in natural areas unless they already common in the immediate area. Even if these grasses currently exist within an area, it may still be desirable or even necessary to prevent their proliferation.

Exp-C10 – Selection of plants to control erosion

Trees, shrubs and ground covers all provide different erosion control functions. While trees and shrubs may be an important component of the overall environmental and an important landscape outcome of the development, over the short-term, revegetation efforts should initially focus on the provision of ground cover vegetation to control surface erosion.

The root systems of trees and shrubs primarily provide the *anchorage system* to prevent the mass movement of steep or high slopes. The surface coverage of grasses and ground covers primarily provides control of surface scour caused by high velocity

flows, while both surface mulch and ground cover vegetation can be used to control raindrop impact erosion.

Exp-C11 – Fragmented bushland

In some cases, significantly less overall environmental disturbance will result from a road reserve being constructed along the edge of a bushland reserve rather than running the road through the middle of the reserve, even though both cases result in the same total area of disturbance. Expert advice should be sought on these matters on a case-by-case basis.

Exp-C12 – Plant roots

Typically, most garden plants have their root system contained within the top 300 to 500mm of soil. *“The roots of most trees extend horizontally well beyond the branches. Often, about 60% of the total root system of large trees is outside the drip circle”* (Handreck, 1993).

Exp-C13 – Soil compaction by planting equipment

Wherever reasonable and practicable, the use of heavy, rubber tyred construction equipment should be avoided. Tracked vehicles used with conventional farm equipment have in the past been considered to produce the best results; however, recent agricultural research has questioned this theory.

Exp-C14 – Protection of plants prior to planting

Plant roots can be packed in moss, coated with kaolin clay, or immersed in a slurry containing water-absorptive starch crystals, before being carried to the field in planting bags or containers.

Exp-C15 – Cleaning of equipment

Cleaning equipment before entering environmentally sensitive areas, and after leaving weed-infested areas where invasive or State-declared weeds occur (e.g. *Parthenium hysterophorus*), is very important and may be conditional in accordance with development conditions or State law. Advice may need to be obtained from the local office of the Department of Natural Resources (or equivalent department).

Exp-C16 – Topsoil

When establishing plants from seed, the preparation of a loose and friable seedbed is essential. If the soil is too dry when cultivated, it will lose its structure; if too wet, the soil may become compacted.

Topsoils should **not** be stripped when they are excessively wet (i.e. the soil can be easily smeared by hand or if water can be squeezed from the soil) or too dry (i.e. if the soil readily crumbles when handled and cannot form a clump when compressed).

Exp-C17 – pH (soil)

Soil pH varies depending on the laboratory methodology used. When referring to soil pH it is very important to note the ratio of soil to extractor ratio e.g. 1:1, 1:2 or 1:5, and the extractor, e.g. water, sodium chloride, calcium chloride, or potassium chloride. It is noted that soil pH (soil:water 1:5) is typically equivalent to pH (CaCl₂ 1:5) plus 0.5 to 1.0 pH units depending on soil type and conditions.

Most plants grow best when soil pH is in the range 5.5 and 8.0, but most plant nutrients are readily available in the pH range of 6.5 to 7.5.

Alkaline soils (pH > 7) are common in arid zones. Strongly alkaline soils (pH > 8.5) may indicate sodicity problems.

Strongly acidic soils (pH < 5.5) are common in the humid tropics. It is noted that toxic levels exist for manganese (Mn) at pH < 5.5 and aluminium (Al) at pH < 5.0. Phosphate fixation occurs in strongly acid, iron-rich soils, and may lock up 85 to 90% of the phosphorus applied in fertiliser.

Exp-C18 – Electrical conductivity

Electrical conductivity is a measure of the conduction of electricity through water or a water extract of soil. It can be used to determine the soluble salts in the extract and hence soil salinity. The unit of electrical conductivity is the siemens and soil salinity is normally expressed as milli-Siemens per centimetre (or deci-Siemens per metre) at 25°C.

Traditionally, the electrical conductivity of saturated extracts was used (EC_{se}), however, electrical conductivity is now determined using a 1:5 soil/water suspension ($EC_{1:5}$).

$$EC_{se} \text{ (dS/m)} = EC_{1:5} \text{ (dS/m)} \times \text{Multiplier factor}$$

The relevant “multiplier factor” is dependant on the soil texture.

Conductivity values of 1.5 ($EC_{1:5}$ for a 1:5 soil:water suspension) or 4.0dS/m (EC_{se} for a saturation extract) indicate the likely occurrence of plant growth restrictions (Houghton & Charman, 1986).

Table C8 – Interpretation of electrical conductivity of saturated extract^[1]

| EC _{se} (dS/m) ^[2] | Rating | Likely effect on plants |
|--|-------------------|---------------------------------------|
| < 2 | Non-saline | Salinity effects mostly negligible. |
| 2–4 | Slightly saline | Sensitive plants affected. |
| 4–8 | Moderately saline | Plant growth affected. |
| 8–16 | Highly saline | Use of only salt tolerant plants |
| > 16 | Extremely saline | Use of only very salt tolerant plants |

Notes:

[1] Modified from Hazelton & Murphy (1992)

[2] Electrical conductivity for saturated soil:water solution

Exp-C19 – Exchangeable sodium percentage

The exchangeable sodium percentage (ESP) is that proportion of the cation exchange capacity occupied by sodium ions, expressed as a percentage. Clays with ESP of 6 to 15% are considered moderately dispersible and are likely to be susceptible to tunnel erosion. Clays with ESP greater than 15% are considered highly susceptible to both tunnelling and surface sealing.

Table C9 – Sodic soil rating

| Exchangeable sodium percentage (ESP) | Rating |
|--------------------------------------|----------------|
| < 6% | Non sodic |
| 6% and up to 15% | Sodic |
| equal to or greater than 15% | Strongly sodic |

Exp-C20 – Cation Exchange Capacity

The cation exchange capacity (CEC) is the total amount of exchangeable cations (calcium, magnesium, potassium, sodium, hydrogen, aluminium and manganese) that a soil can absorb, expressed in centimoles of positive charge per kilogram of soil.

The CEC is affected by the type of clay in the soil which provides a buffering effect to changes in pH, available nutrients, calcium levels and soil structural changes. Dark cracking clays high in the clay mineral montmorillonite, have a high CEC. The red clays in tropical areas, with kaolinite as the major clay mineral, have a lower CEC than dark clays, but are usually higher than sandy soils. A low CEC means the soil has a low resistance to changes in soil chemistry caused by land use.

Soils with low cation exchange capacity (CEC) exhibit the following characteristics:

- generally acidic, kaolinitic clays
- often have a low humus content
- have low abilities to hold cations
- weakly supply cations to growing plants
- generally low fertility soils
- commonly found in the humid tropics

Table C10 – Effective cation exchange capacity (ECEC)

| ECEC (meq/100g) | Rating |
|-----------------|-----------|
| < 6 | Very low |
| 6–12 | Low |
| 12–25 | Medium |
| 25–40 | High |
| > 40 | Very high |

Table C11 – Desirable cation proportions

| Cation | Desirable range (% of ECEC) |
|--------|------------------------------|
| Ca | 65–80 |
| Mg | 15–25 |
| K | 2–4 |
| Na | < 6 (but as low as possible) |
| Al | < 5 (but as low as possible) |

Exp-C21 – Lime

Coarser textured soils generally require less lime than finer textured soils. Lime is normally incorporated into the soil just before, or during, sowing. Lime can be spread on the surface but the response time is much slower than when it is incorporated into the soil.

Lime in soil will perform the following functions (Hunt 1992):

- raises soil pH
- increases soil calcium
- reduces toxic manganese and aluminium levels
- increases molybdenum availability
- enhances legume modulation

Agents **not** recommended to modify acidity include:

- Quicklime: [CaO] finely ground, burnt limestone (caustic).
- Hydrated lime, slaked lime: [Ca(OH)₂] formed from quicklime that has reacted with water; (extremely caustic).

Alternatively, as a rough guide, for 1 unit change in pH of the top 100mm of soil, apply limestone at about 100g/m² for sandy soils (equivalent of 1.0t/ha), 200g/m² for loams soils, and 400g/m² for clay soils (Handreck, 1993). Actual application rate depends on the “buffering capacity” of the soil, and the “quality” of the neutralising agent.

The full effects of the liming may take a couple of months for builder’s lime and perhaps a year for ground limestone. It is noted that for every 1 tonne of lime or dolomite applied to the soil, 440kg of carbon dioxide will eventually be released to the atmosphere as an unavoidable result of neutralising soil acidity.

Aglime is a neutralising agent used to treat acidic soils; by composition, it is commonly 95 to 98% pure calcium carbonate (CaCO₃); it is sparingly soluble in pure water, and has a pH in water of approximately 8.3; application rates will depend on the purity and fineness of the product (Dear et al. 2002).

Exp-C22 – Dispersive soil

Dispersive (dispersible) soils are structurally unstable in water, breaking down into their constituent particles (sand, silt and clay) and consequently allowing the dispersible clay fraction to disperse and cloud the water. This dispersion is caused by the high, negative, electro-static charge on the surface of particles typically less than 0.005mm in diameter (i.e. clay and smaller silt-sized particles).

Dispersion is caused largely by high levels of exchangeable sodium in the soil and excessive mechanical disturbance, especially if the soil is wet. Not all particles finer than 0.005mm are dispersible. Illite clays can become dispersible if disturbed when wet, while montmorillonite clays have a greater tendency to be dispersive in all circumstances.

Highly dispersive soils are normally highly erodible and are likely to cause problems to road cuttings and dam/pond embankments. They are structurally unstable soils.

Dispersive soil can cause the following problems:

- highly erodible and unstable soils;
- high levels of turbidity in stormwater runoff;
- severe rilling of unprotected earth batters;
- high susceptibility to tunnel erosion (dam failure);
- tunnelling behind rigid (e.g. concrete) and semi-rigid (e.g. gabions) surfaces;
- transportation of nutrients (e.g. phosphorus) and metals “piggybacking” on the dispersed clay particles.

Some aggregates readily disperse when immersed in water, while others require remoulding (i.e. mechanical energy input) before the dispersion properties become evident. Soils that require remoulding to disperse usually do not represent an erosion hazard until disturbed by construction activities or recent raindrop impacts.

Soils are considered significantly dispersive if the combined decimal fraction of clay (<0.002mm) plus half the percentage of silt (0.002–0.02mm), multiplied by the dispersion percentage; is greater than 10%.

In most circumstances, the best engineering treatment of dispersible soils is to ensure the soils are buried under a layer of non-dispersive soil before the final surface treatment (e.g. grass seeding, turfing, rock, concrete, rock mattresses) is applied. The minimum thickness of the non-dispersive soil layer is generally between 50 and 300mm depending on the likely level of exposure of the soil surface to erosion risks. A

minimum cover of 100mm is generally recommended on gentle slopes and 200mm on steep slopes.

Dispersive soil should generally not be directly seeded, or covered with an *Erosion Control Blanket* and seeded. A layer of non-dispersive soil must always be placed over the dispersive soil before placement of vegetation or *Erosion Control Blankets*.

If sufficient quantities of non-dispersive soil are not readily available, then a stockpile of non-dispersive soil may be made from an in-situ dispersive soil through the application of sufficient quantities of gypsum (or similar source of calcium) well-mixed into the soil.

The most widely used tests for the assessment of aggregate stability relating to soil dispersion are the exchangeable sodium percentage (ESP), dispersion percentage (DP), and Emerson Aggregate Test (EAT). Each of these tests reflect a specific aspect of soil aggregate stability.

Table C12 – Emerson aggregate classification ^[1]

| Emerson Aggregate Class | Dispersibility |
|-------------------------|------------------|
| 1 and 2(3) [2] | Very high |
| 2(2) | High |
| 2(1) | High to moderate |
| 3(4) and 3(3) | Moderate |
| 3(2), 3(1) and 5 | Slight |
| 6, 7, 8 | Negligible |

Notes:

[1] Modified from Hazelton & Murphy (1992)

[2] Value in brackets represents the sub-class of the Emerson Test

Table C13 – Soil usage based on Emerson aggregate classification ^[1]

| Emerson Class | Likely soil usage |
|---------------|--|
| Class 1 | Soil highly susceptible to tunnelling. |
| Class 2 | Soil susceptible to tunnelling. |
| 2(1) | – desirable for use in water storage structures to ensure sealing ^[2] |
| 2(2) | – unstable |
| 2(3) | – unstable |
| Class 3 | Soils generally stable and desirable for use in soil conservation earthworks. |
| 3(1) | – most suitable for earthworks |
| 3(2) | – crusting of soil may be a problem; questionable usage for earthworks |
| 3(3) | – questionable usage for earthworks |
| 3(4) | |
| Class 4 | Soil may not hold water. |
| Class 5 | Soil may not hold water. |
| Class 6 | Soil unlikely to hold water. |

Notes:

[1] Modified from Hazelton & Murphy (1992)

[2] Provided compacted at correct water content and not allowed to dry and form deep cracks.

Table C14 – Dispersion percentage ^[1]

| Dispersion percentage (%) | Rating |
|---------------------------|------------|
| < 6 | Negligible |
| 6–30 | Slight |
| 30–50 | Moderate |
| 50–65 | High |
| > 65 | Very high |

[1] After Hazelton & Murphy (1992)

The exchangeable sodium percentage (ESP) is the percentage of cation exchange capacity (CEC) represented by exchangeable sodium and is the most common indicator used for determining dispersion potential in sodic soils. A soil with an ESP of less than 6% is considered non-sodic soil, and therefore, not likely to be dispersive.

Exp-C23 – Revegetating arid and semi-arid land

Vegetative measures may not be the most suitable means of controlling soil erosion within arid or even some semi-arid areas. Consideration should be given to non-organic mulches. The best design option is to study the surrounding area and try to simulate the “natural” erosion control measures of the area.

The aim when planting on very dry soils is to maximise infiltration of available rainfall, maximise soil-water storage and minimise evaporation. Various mulches can be used to improve soil moisture retention and remove competing surface vegetation. On slopes, *Flow Diversion Banks* may be used to direct any surface runoff to the plants and hold it there with mini-pondage banks.

When soil moisture is normally only available well below the surface, it may be necessary to establish seedlings externally in long tubes to establish a long root system. Such plants need to be established well in advance of the planting schedule.

In arid and semi-arid land, use may also be made of special containers filled with water and partially buried into the soil, or propriety products filled with special water-retaining gels.

Exp-C24 – Revegetating dispersive soils

In most circumstances, the best engineering treatment of dispersive soils is to ensure the soils are buried under a layer of non-dispersive soil before the final surface treatment (e.g. grass seeding, turfing, rock, concrete, rock mattresses) is applied. The minimum thickness of the non-dispersive soil layer is generally between 50 and 300mm depending on the likely level of exposure of the soil surface to erosion risks. A minimum cover of 100mm is generally recommended on gentle slopes and 200mm on steep slopes.

Dispersive soil should generally not be directly seeded, or covered with an *Erosion Control Blanket* and seeded. A layer of non-dispersible soil must always be placed over the dispersible soil before placement of vegetation or *Erosion Control Blankets*.

Exp-C25 – Revegetating exposed (windy) sites

On exposed sites, newly planted trees may be protected by:

- placement of artificial windbreaks of brushwood or netting;
- initial planting of exposure-tolerant species;
- staking and/or pruning to prevent wind damage;
- use of tree guards such as clear plastic tubes or metal drum surrounds.

Exp-C26 – Revegetating hardsetting and surface sealing soils

These soils are best treated by cultivation and surface roughening, then covered with water absorbing mulch (Hunt, 1992). Gypsum can improve soil structure and reduce crusting in some hardsetting clayey soils.

Excessive cultivation, however, can also break down the soil structure and increase the risk of forming hard setting or surface sealing soils. Mulching after seeding will reduce raindrop impact and improve seedling establishment.

Exp-C27 – Revegetating saline soils

Saline soils contain limited amounts of plant available water. Plant growth benefits from heavy mulching, the use of cover crops and large applications (300 to 800kg/ha) of high nitrogen and phosphorous mixed fertiliser such as diammonium phosphate (Hunt, 1992).

Reclaiming salt-affected land is very slow, expensive and often not effective. The risk of salt damage to land can be decreased by appropriate catchment planning. Such planning should include the retention of trees in areas of high salinity risk and along hilltops, fencing off affected areas to prevent grazing, and the planting of salt-tolerant, deep-rooted plants. In cases where the soil structure has broken down, gypsum can be applied. The calcium in gypsum reduces the effects of sodium on soil structure.

High watertables can increase the potential for salinity to adversely affect site revegetation unless appropriate steps are taken.

The key to revegetation is understanding the mechanism by which salt is accumulating in the soil. In saline soil areas the aim is to leach salts away from the soil surface and deep into the soil profile. This is achieved by (Hunt, 1992):

- Lower watertable levels.
- Increasing the amount of water that infiltrates into the soil by applying mulch and gypsum.
- Drainage of salty water by deep ripping (in conjunction with gypsum slotting) and installation of deep intersection drains (which may include deep cut channels or traditional agricultural drains).
- Introducing water-demanding plants.

Revegetation with salt tolerant species may be initially established on mounds or banks up to 500mm in height. Mounds should be prepared several months before planting to allow some salt to be flushed from the system. Heavy mulching of the mounds around each planting site will help reduce evaporation and subsequent salt accumulation at the soil surface. The trees should be planted into deep holes on the top of the mound after scraping away the top 20mm of soil.

Exp-C28 – Revegetating sandy soils

Sandy soils are excellent for turf areas that are intensively managed and must withstand compaction such as bowling greens. When located within general residential areas, sandy soils will require more frequent watering (depending on plant selection) and the use of soluble fertilisers applied frequently and in small doses.

Expert advice should be obtained on choice of fertiliser and application rates. Excessive fertiliser usage has a high potential to cause adverse off-site effects due to the high leaching rates of sandy soils.

Sandy soils are often water repellent caused by the presence of waxy materials on the surface of the sand produced mainly by fungi as they decompose organic material

(Handreck, 1993). This condition may need to be amended through the use of wetting agents.

Exp-C29 – Revegetating soils with inadequate available water-holding capacity

Soils with an inadequate available water holding capacity are generally difficult to revegetate unless a frequent, light application of water is available, either by watering or regular light rainfall.

Certain soil textures and structures limit the amount of soil-water that can be made available to plants. Revegetating these soils may require texture changes through the addition of more clay or organic material, adjustments to the frequency and quantity of watering (i.e. regular light watering), and/or the addition of mulch and/or commercial soil ameliorants.

Use of special drought resistant plants is recommended for these soils. The addition of materials into the soil that help store water can assist in revegetation. Such materials may include bentonite clays, super-absorbent polymers, or organic materials such as peat moss.

Exp-C30 – Revegetating steep slopes

It is often difficult to establish vegetation on slopes steeper than 2:1(H:V), especially if the bank has a southern aspect (i.e. away from direct sunlight). In such cases, structural retaining walls may be considered to either replace the embankment or reduce the vegetated section of the slope. Provision for appropriate drainage of steep slopes is critically important because saturation of the soil can lead to sudden loss of strength and catastrophic landslips.

Steep slopes present problems of soil creep and slippage that can bury plants. It may be necessary to establish a non-competitive groundcover to stabilise the slope during the development period of the preferred species. Planting should progress down the slope. On very steep slopes, planting may be confined to benched sections or anchored with rock-fall netting.

Careful observations of surrounding vegetated slopes should be made when planning vegetation for the rehabilitation of mines, dams and highway/railway embankments.

On steep slopes, soil stabilisation techniques need to control surface movement (soil creep), shallow-seated instabilities (within 2m of the surface) and deep-seated instabilities. Ground covers, such as grasses and herbs, can be used to control surface movement, and shrubs and trees are suitable for the control of shallow-seated instabilities. Deep-seated instabilities, however, are generally beyond the limits of most root systems and must be controlled by proper geotechnical design.

It should be noted that after tree clearing, the retained root system might continue to provide decreasing structural stability to a slope for several years. Thus the apparent stability of a steep slope immediately after tree clearing is no guarantee that future bank stabilisation works will not be required. In most cases, revegetation with similar deep-rooted trees will be required after site development or land shaping has been completed.

Exp-C31 – Revegetating waterlogged soils

Soils that have been saturated for long periods are likely to be deficient in soil air and most nutrients, particularly nitrogen and potassium. Frequent applications of small quantities of fertilisers, or the use of slow release fertilisers, is generally more effective than the application of large, infrequent doses (Hunt, 1992).

Plant species should be selected which are tolerant to prolonged soil saturation.

Soil test should aim to determine the likely impact on revegetation caused by chemical changes in the soil resulting from any proposed drainage works.

Exp-C32 – Revegetating water repellent soils

Water repellent soils are best treated by cultivation or ground preparations that aim to leave a series of small water-holding depressions. The application of soil wetting agents may also be considered (Hunt, 1992).

Water repellent soils do not readily absorb water when they are dry. They typically are sandy or sandy loam soils and can be difficult to revegetate. Treatments include mechanical disturbance and wetting agents.

Exp-C33 – Revegetating water storage embankments

On some dams and large detention basin embankments, maintaining a desirable ground cover may be difficult due to low ground water levels around the crest of the embankment. In such cases, consideration may need to be given to the establishment of a permanently installed underground watering system along the embankment crest.

The placement of trees and shrubs on the downstream side of a dam embankment that has the potential to be overtopped in an extreme event is **not** recommended, and in most cases must be avoided. Deep-rooted plants located on the upstream side of the embankment can cause seepage problems after the plants have died and the root system begins to rot away, especially if short-lived species are used.

Exp-C34 – Excessive soil compaction

Soil compaction can be measured in terms of its bulk density. Bulk density is the mass of dry soil per unit bulk volume. The range for soils in natural condition would typically be from 1 to 2g/cm³ (Houghton & Charman, 1986). The specific gravity of soil is typically 2.65g/cm³, with the total porosity being given by the following equation:

$$\text{Total porosity} = (1 - (\text{bulk density})/(\text{specific gravity of soil})) \times 100$$

Critical values of bulk density for plant growth at which root penetration is likely to be severely restricted are:

Table C15 – Critical bulk density for restricted plant growth^[1]

| Texture | Critical bulk density (g/cm ³) |
|--------------------|--|
| Sandy loam | 1.8 |
| Fine sandy loam | 1.7 |
| Loam and clay loam | 1.6 |
| Clay | 1.4 |

[1] After Hazelton & Murphy (1992)

Table C16 – Bulk density conditions^[1]

| Bulk Density (g/mL) | Sands | Loams | Clays |
|---------------------|------------------|-------------------|-------------------|
| < 1.0 | — | good conditions | satisfactory |
| 1.0–1.2 | — | satisfactory | satisfactory |
| 1.2–1.4 | very open | satisfactory | some too compact |
| 1.4–1.6 | satisfactory | some too compact | very compact |
| 1.6–1.8 | most too compact | very compact | extremely compact |
| > 1.8 | very compact | extremely compact | — |

[1] Sourced from Ross Coventry, James Cook University, Townsville

A bulk density of 1.4g/cm³ (equivalent to g/mL or t/m³) is typically assumed in general soil loss analysis and RUSLE (Appendix E – *Soil Loss Estimation*) calculations.

Excessive soil compaction may be managed by:

- ripping the top 150mm (typical) – disc cultivator, or chisel plough;
- deep ripping if hardpans are detected during site investigations;
- cultivating the soil when it is dry enough to form small clods;
- treating the soil with gypsum if dispersive or sodic;
- avoiding the use of rotary hoes and traffic when the soil is wet.

Features of contour ploughing to reduce bulk density include:

- Machinery such as tractor and chisel plough.
- Cheap and cost effective.
- Prepares land surface for establishment of vegetative cover.
- Limited to slopes of less than about 5 degrees.

Features of contour ripping to reduce bulk density include:

- Machinery such as single or multi-tine ripper (600–900mm deep) behind a heavy tractor or bulldozer.
- Often 2 to 3 tines forming furrows 2–6m apart depending on slope.
- Limited to slopes of less than 10 degrees.

Exp-C35 – Quality control

It may be prudent to take a few random samples of any seed delivered to the site to test for purity and germination. When working near sensitive bushland areas, such as bushland reserves and National Parks, it is important that the seed supply is of the required standard and that the revegetation program does not introduce undesirable weed species to the area.

Exp-C36 – Control samples

To check the health of supplied trees and shrubs, samples should be planted in test beds containing good soil. The use of these specially prepared beds allows assessment of the plant's response to an optimum soil as compared to its response to the site's soils.

Exp-C37 – Cutting of plant roots

Failure to cut or remove circling roots can either restrict mature plant growth or cause death to the tree in 6 to 8 years because the enlarged circling roots choke the plant (Handreck, 1993). The attention to circling roots is less critical with shrubs but is still desirable.

Exp-C38 – Monitoring seed application rates

A useful way of checking on the overall seeding process—especially when hydroseeding or broadcasting the seed—is to bury a series of rigid seed trays in the ground within the area being seeded. The tops of the trays should be set level with the ground surface, then filled with local soil (or left empty, if only to check on seed distribution). The trays are then removed after the seeding process and kept in moist, sheltered conditions where germination should be ideal. After germination, the trays are examined to assess the purity of the seed.

Exp-C39 – Plant watering rates

Watering should start immediately after turfing, or sprigging or, in the case of seeding, as soon as possible after planting, but in any case no later than 48 hours after seeding.

Watering requirements will vary significantly depending on the weather, regional factors, and the soil conditions; however, a typical watering schedule is listed below:

- 25mm every second day for the first three waterings;
- 25mm twice a week for the next three weeks; and
- 25mm once weekly for a further two weeks.

Rain of more than 20mm in one day can be taken as a substitute for a single watering.

Exp-C40 – Initial plant watering

Plant seeds need water to germinate. Water enters the seed causing it to swell and the seed coat (testa) to split. This allows the emergence of the young root (the radicle). Relying on food reserves within the seed, the first leaves (plumules) start to grow and emerge from the soil. Only after emerging from the soil can the plant finally use sunlight to generate ongoing energy (photosynthesis).

Once the radicle has emerged from the seed, the seedling is very vulnerable to drying out until the roots grow into moist soil. If the soil dries, germination stops and any growing seedling will die. Seeds planted too close to the surface are likely to dry out, while those sown too deeply can run out of food reserves before breaking through to the surface. Planting density, mulch application and watering rates all influence how much water is available for germination and ongoing growth.

Exp-C41 – Mulching

The establishment of planted trees and shrubs can be improved by controlling the soil moisture around the root system during the first few weeks. This can be done by removing and controlling competing ground cover in the immediate area by using a weed control mat or a thick layer of mulch (greater than 75 to 100mm) placed over at least a 1m diameter area.

When applied around trees for weed and moisture loss control, the mulch should spread from 1 to 1.5m all around the stem. It should **not** touch the stem directly. Ideally mulch should be applied directly after the tree is planted and before watering.

Mulch can also provide significant benefits to saline soils by reducing evaporation, to steep slopes by controlling erosion, and to cracking clays by reducing the severity of the cracks.

It is noted those organic mulches which are largely wood or bark based often draw nitrogen from the soil as they decompose. In soil of low fertility, any fertiliser meant for the tree should be incorporated into the soil rather than into the mulch.

Exp-C42 – Planting into subsoils

Direct planting into subsoils should be avoided, unless the vegetation is used as a temporary cover to protect the subsoil during a delay in construction. If vegetation is to be established in a subsoil, then the soil may need to be heavily fertilised followed by deep ripping. The application of fertiliser will depend on the soil's existing fertility, its drainage characteristics, and the expected weather conditions.

Heavy applications of mulch or other organic matter may help build-up the subsoil and protect the plant and soil surface during the initial planting phase.

Exp-C43 – Mulching

Mulching is the use of plant residue or other suitable material to cover the soil surface. Mulching has the benefits of assisting in the retention of soil moisture and regulation of soil temperature. In the longer term it can improve soil structure, nutrient status and weed control.

Mulch should be spread evenly with a maximum depth of 50mm (light mulching) when placed over seed.

Exp-C44 – Heavy mulching

Mulching to a depth of 75 to 100mm (heavy mulching) will generally inhibit seed germination, and is thus used for moisture retention and weed control around tube stock and established plants.

When applied around established trees for weed and soil moisture control, the mulch should spread from 1 to 1.5m all around the trunk. It should **not** touch the trunk directly. Ideally mulch should be applied directly after the tree is planted and before watering.

Exp-C45 – Anchoring of mulch on slopes

It is often desirable to hold the mulch in position to reduce loss by wind and water runoff, especially on sloping ground. This may be achieved using one or more of the following methods:

- light discing into the ground;
- working a tracked dozer up and down the slope;
- covering with biodegradable, synthetic or wire mesh—used with extreme caution due to its potential to trap or injure wildlife;
- application of a slow setting (anionic) bitumen emulsion;
- regularly spaced and anchored logs.

Mulch generated through either horizontal or tub grinder, **not** chipping, is likely to be more stable on sloping ground.

Exp-C46 – Woody mulches

Organic mulches that contain a large quantity of wood or bark can draw nitrogen from the soil as they decompose. In soil of low fertility, any fertiliser meant for the tree should be incorporated into the soil rather than into the mulch.

Freshly cut vegetation such as grass, and baled hay or straw, will also take-up nitrogen as it decomposes. Some mulches can produce significant quantities of heat that could burn the roots and stem of trees. To avoid this, ensure that:

- the mulch does not have direct contact with plant stems;
- only appropriately aged mulch is used;
- the mulch is appropriately stockpiled.

Exp-C47 – Required soil cover

Independent of the type of revegetation or the stage of revegetation, a soil coverage of at least 70% is considered necessary to adequately control raindrop impact erosion, particularly on clayey soils. In the early stages of revegetation, such soil coverage is usually achieved through the application of a mulch layer or *Erosion Control Blanket*.

As a general rule, when fully established, at least 70 to 80% of the soil surface should be covered with grasses or herbaceous plants in order to obtain suitable erosion control. At least 70% coverage is typically required in temperate climates and at least

80% coverage is required in tropical areas. Similarly, the lateral root system should occupy more than 60% of the surface area.

Exp-C48 – Inspection test plans

Inspection test plans (ITPs) detail the inspection, testing and performance criteria for key site and construction activities. ITPs have been used extensively to control the revegetation phase. Example ITP clauses are provided in Chapter 7 – *Site Inspection*.

Exp-C49 – Willowing

“Willowing” is a term used to describe the practice of planting vegetative material, stems or roots along shallow excavated trenches cut along waterway banks or steep embankments. It does **not** necessarily mean the planting of willows. The material (stakes) takes root, thereby stabilising the embankment. Only selective plant species, such as some native acacias can be established by such planting techniques in Australia. The technique is sometimes known as *Soil Bio-Engineering*.

Exp-C50 – Hand seeding

Hand seeding includes hand broadcasting, spot seeding and sprig planting.

Hand seeding is suitable for small areas or when introducing different species in selected areas. Hand seeding or planting may require the additional work of soil conditioning whereby the excavated soil is mixed with ameliorants such as compost, manure, water-retaining polymer or slow-release fertiliser, before being backfilled around the seed or roots system. Couch grass seed should be mixed with an equal quantity of loam before spreading to prevent uneven distribution.

Hand sprig planting is labour intensive and suitable only for small areas. It may be used to establish grasses such as kikuyu or buffalo that do not reproduce easily from seed. If the turf or grass sod is already well mixed within the topsoil, it may be spread and cultivated without the need for manual labour. Sprigs should be spread in two equal applications in transverse directions over the area to be grassed. The soil surface should then be turned (e.g. rotary hoe) to a depth of 75mm to mix the sprigs thoroughly into the topsoil. Finally the surface should be lightly raked to provide an even grade.

In all cases, the application of a light mulch layer is desirable to adequately control raindrop impact erosion and to reduce moisture loss from the soil.

Exp-C51 – Drill seeding

A drill seeder is a sowing machine that can simultaneously insert seed and fertiliser into the soil. Drilling is generally limited to slopes less than 3:1 (H:V). Placing the seed and fertiliser below the soil surface increases the potential for germination and reduces loss of seed to wind, ants and birds. Germination is generally improved by lightly rolling the seeded area to improve contact between the seed and soil.

When topography, terrain (i.e. slope < 15°) and soil characteristics (non-stony or heavy soils) permit, seeding can be carried out with conventional agricultural seed drills.

Exp-C52 – Broadcast seeding

Broadcasting is a cheap and convenient method of seeding on most areas accessible to wheeled tractors. The soil surface should be roughened before seeding. Mulch should be applied afterwards to control raindrop impact erosion and soil moisture loss, especially when the weather is sunny, hot and/or windy. Fertiliser is usually applied in a separate operation.

If a tail mounted spinner is used, the fertiliser, cover crop seed and perennial grass seeds should be spread in three separate passes to prevent segregation. It may be

advantageous to spread the bulk of the fertiliser immediately before the initial cultivation to reduce possible wash-off. The fertiliser will also have broken down into a form more readily available for plant uptake. Following application of the fertiliser, the area to be sown should be cultivated on the contour.

Deep ripping along the contour with a single tined ripper (each pass being one tractor width apart) will assist infiltration and storage of soil moisture. This will provide additional insurance against poor germination and establishment caused by a lack of moisture in hardsetting soils.

Machine broadcasting by agricultural “spinners” or pneumatic broadcasting equipment is generally limited to slopes less than 3:1 (H:V). Fertilisers and soil ameliorants should be applied first, then incorporated into the soil. Finally the seed is applied and lightly covered with soil. A suitable light mulching is then applied in the final pass.

Exp-C53 – Sprigging

The mechanical spreading of turf, grass sod, or soil containing vegetative parts suitable for regrowth. The method typically uses such grasses as couch or kikuyu. This technique is normally used in conjunction with over-sowing of suitable species, which ensures that a more uniform cover develops.

The source area should preferably have a dense cover of couch or kikuyu with excess leaf litter removed. The turf or sod is broken into pieces (approximately 100 x 100mm) by ploughing at right angles.

If sowing is to follow the spreading operation, it should be into freshly disturbed soil. If it is delayed, or compaction occurs, a light harrowing is recommended to prepare the ground.

Sprigs should be spread in two equal applications in transverse directions over the area to be grassed. Immediately rotary hoe or lightly disc the area to a depth of 75mm to mix the sprigs thoroughly into the topsoil. The surface should then be lightly raked to provide an even grade.

Exp-C54 – Hydroseeding, hydromulching, BFM, compost blankets

Hydroseeding (the jetting of seeds in a water-based slurry) does not provide any initial erosion protection to the soil unless supplemented with a light mulch cover.

Hydromulching is the spraying of a homogenous mix of seed, fertiliser, a cellulose mulch, mulch tackifier and water onto the soil.

Bonded fibre matrix (BFM) is a hydraulically-applied mix of seed, fertiliser, a cellulose mulch, mulch tackifier and water which dries to form a seeded erosion control blanket. BFMs are made up of a range of fibre lengths with a high percentage of long fibres which provide increased strength compared to a hydromulch. Unfortunately not all hydroseeders are capable of applying a BFM.

Both hydroseeding and hydromulching are susceptible to failure if applied to a “glassy” smooth, compacted, or surface sealed soil. Proper soil surface preparation is essential.

Compost Blankets consist of a surface application of composted organic material containing selected plant seed, fertiliser and tackifier (optional). These organic blankets are commonly used for both erosion control and site revegetation on steep slopes where there is little or no existing topsoil, or where the in-situ topsoil cannot be reused.

Exp-C55 – Seed mat

Seed mats are a variation to mulching where a pre-seeded geotextile mat is rolled out and pegged directly onto the ground. Prior to placement, the ground is fertilised then raked to remove all surface irregularities. It is very important that the mat is installed and fixed (anchored) in good contact with the ground over all its area.

Exp-C56 – Turf (sod)

A piece of earth containing plants with matted roots. Frequently used for the revegetation of critical areas where a stable vegetative sward is required for erosion control. Grasses such as kikuyu and couch, which have stolons, are particularly suited to this method of revegetation (Houghton & Charman, 1986).

Turf should be:

- placed on a minimum 75mm bed of fertilised topsoil;
- laid with the strips firmly butted together in a staggered arrangement parallel to the contour on sites with steep slope gradients, or normal to the direction of flow within overland flow paths;
- rolled or tamped then watered immediately it is laid;
- pegged to the soil at 1-2m centres (where necessary).

Plugging is the application of small pieces of turf around 75mm square. This process is only recommended on level areas or during the dry season when rain and runoff damage is not expected. Plugs may be planted at 225mm centres followed by a light top dressing, then rolled.

Exp-C57 – Trash blankets and brush matting

Local native vegetation (branches including their seed) can be spread over the soil surface to promote the regeneration of local provenance plants. The brush also provides initial protection against raindrop impact erosion; however, protection against high-velocity surface flows depends on placement and anchorage of the brush.

This technique can be labour intensive and expensive when applied over a large area.

Exp-C58 – Dispersive soils

In dispersive soil regions, erosion problems are commonly initiated at significant changes of grade within stormwater drains. For example, when table drains divert from the edge of a road and release their water into a larger receiving drain or watercourse, gully erosion often initiates at this change of grade. This gully erosion can then migrate up the table drain undermining any successful revegetation that has occurred within the drain.

On steep batters containing dispersive subsoil, severe rill erosion can undermine an otherwise successful batter revegetation program if maintenance activities, such as grass cutting, damage the toe of the batter causing exposure of the underlying subsoils. Further discussion of these problems is provided in Appendix J – *Road and Rail Construction*.

Exp-C59 – Weed control

Weed control is often a condition of development approval, especially next to parks, bushland and watercourses. It is very important to identify the weeds associated with a particular area and to identify the appropriate treatment method. Advice from recognised experts will be necessary.

Three simple principles should be followed for successful mechanical weed control:

- (i) Treat the weeds before they flower to cut off the future supply of seeds.
- (ii) Treat the weeds in fine weather and when they are growing vigorously. Plants, or portions of them, not completely removed are likely to grow again in wet weather; hot, dry weather ensures a good weed kill.
- (iii) Avoid creating good growing conditions for weed seeds resting in the soil. Excessive stirring of the soil can create seed beds for weed seeds.

It is noted that topsoil can be a major source of weeds, so that care must be taken in sourcing it. Organic material, such as hay, can also be a source of weeds.

In some situations, long-term control of weeds is best achieved by the establishment of an effective tree canopy to control light penetration. Along a watercourse, a healthy tree canopy has many benefits including weed control, but it can also limit the growth of the preferred ground cover resulting in increased bank erosion.

Exp-C60 – Pre-emergent herbicide

A herbicide which is applied to the soil surface after the seed has been sown, but before it emerges. Such herbicides are mainly selective residual or non-selective contact in action, but a few non-selective translocated herbicides are also available. Selective residual herbicides are incorporated by rain or, on rare occasions, by very shallow cultivation.

Appendix D

Example plans

This appendix provides example Erosion and Sediment Control Plans. Its function within this document is primarily educational.

These example ESCPs have been provided for general discussion purposes only. The example ESCPs were developed prior to finalisation of this document and as such the solutions presented do not necessarily represent the appropriate application of the recommended ESC design standards presented in Chapter 4 of this document. No hydrologic analysis has been performed, and sediment control measures have not been individually sized.

D1 Introduction

These example Erosion and Sediment Control Plans (ESCPs) have been presented to demonstrate how ESC measures can be organised on various types of construction sites to control soil erosion and sediment runoff. The ESCPs primarily illustrate the drainage and sediment control measures. Landscaping and erosion control measures would normally be detailed within the ESCP technical notes or associated contract documents.

The following ESCPs demonstrate just one method of controlling soil erosion and sediment runoff within each site. It should not be implied that the ESCPs present the only acceptable method of managing each site.

Due to the restrictions caused by presenting these example plans on A4-size paper, the attached plans are not representative of actual ESCPs. An acceptable ESCP for each of these sites would need to be presented on an appropriately sized plan that allowed adequate presentation and interpretation of all necessary information in accordance with normal engineering drafting standards.

D2 Example site-based Stormwater Quality Management Plan

In addition to the production of ESCPs, some state authorities require developers to prepare site-based (construction phase) Stormwater Quality Management Plans (SQMPs). These plans help to support the implementation of the ESCP.

The following is an extract from an example site-based Stormwater Quality Management Plan. This example does not provide an exhaustive list of the possible components of a SQMP.

Guidance of the preparation of SQMPs that comply with local legislative requirements should be obtained from the relevant state or local authority.

Table D1 – Example site-based Stormwater Quality Management Plan

| Issue | Stormwater Quality Management – Construction Phase |
|---------------------------------|---|
| Purpose: | To provide a set of Best Practice site management procedures to control the severity and extent of soil erosion and pollutant transport during the earthworks and construction phase. |
| Performance Criteria: | <p>Water discharged from the site is to comply with <i>[insert relevant State Act, and date]</i> to ensure that no detrimental impacts on water quality and the environment occur during the construction phase.</p> <p>The quality of discharge from the site to satisfy the following Water Quality Objectives (WQOs):</p> <p>Release Criteria:</p> <ul style="list-style-type: none"> • An increase in suspended solids within surface waters contained in <i>[insert name]</i> – upstream of site to downstream of site – of less than 10%. • Water pH released from a controlled sediment basin outflow must be within the range 6.5 to 8.5. • Suspended Solids released from controlled sediment basin outflows must be no greater than 50mg/L. • Oils and Grease – no visible films or odour. • Litter – no visible litter washed or blown from the site. |
| Responsibility: | <p>The owner of the property will be responsible for the implementation of the Water Quality Monitoring Program (WQMP) during the course of all construction activities.</p> <p>The Construction Contractor will be responsible for the implementation of the Stormwater Management Plan (SWMP) during the course of all construction activities.</p> |
| Implementation Strategy: | <p>Permanent and long-term drains and bund walls to be topsoiled and vegetated with suitable vegetation as soon as possible.</p> <p>Clean-up of general site litter on a weekly basis, prior to anticipated heavy rainfall and after significant rainfall events (>25mm/24hours).</p> <p>Landscaping activities and revegetation to occur as soon as practical after completion of earthworks and construction activities within the immediate area and must achieve a minimum 70% coverage of all erodible surfaces.</p> <p>Only appropriate herbicides and fertilisers to be used.</p> <p>The storage and handling of flammable and combustible liquids is managed in accordance with AS1940–1993.</p> <p>A detailed Erosion and Sediment Control Plan (ESCP) must be submitted to, and approved by, <i>[insert name of regulatory authority]</i> prior to site establishment and commencement of vegetation clearing or soil disturbance within each subdivision stage.</p> <p>Where appropriate, ESCPs must incorporate guidelines on the treatment, protection and stabilisation of exposed dispersive soils.</p> |
| Monitoring: | <p>Erosion and sediment control (ESC) measures to be inspected daily by the site manager (or nominated representative) during periods of runoff-producing rainfall, and de-silted, repaired and amended as appropriate to maintain the WQOs.</p> <p>(a) Daily site inspections, during periods of runoff-producing rainfall must include:</p> <ul style="list-style-type: none"> • all drainage, erosion and sediment control measures; • occurrences of excessive sediment deposition (whether on-site or off-site); • all site discharge points. |

| | |
|---|--|
| | <p>(b) Weekly site inspections must include:</p> <ul style="list-style-type: none"> • all drainage, erosion and sediment control measures; • occurrences of excessive sediment deposition (whether on-site or off-site); • occurrences of construction materials, litter or sediment placed, deposited, washed or blown from the site, including deposition by vehicular movements; • litter and waste receptors; • oil, fuel and chemical storage facilities. <p>(c) Site inspections immediately prior to anticipated runoff-producing rainfall must include:</p> <ul style="list-style-type: none"> • all drainage, erosion and sediment control measures; • all temporary (e.g. over-night) flow diversion and drainage works. <p>(d) Site inspections immediately following runoff-producing rainfall must include:</p> <ul style="list-style-type: none"> • treatment and de-watering requirements of sediment basins; • sediment deposition within sediment basins and the need for its removal; • all drainage, erosion and sediment control measures; • occurrences of excessive sediment deposition (whether on-site or off-site); • occurrences of construction materials, litter or sediment placed, deposited, washed or blown from the site, including deposition by vehicular movements; • occurrences of excessive erosion, sedimentation, or mud generation around the site office, car park and material storage areas. <p>(e) In addition to the above, monthly site inspections must include:</p> <ul style="list-style-type: none"> • surface coverage of finished surfaces (both area and percentage cover); • health of recently established vegetation; • proposed staging of future site clearing, earthworks and site/soil stabilisation. <p>Water quality monitoring must be carried out on any controlled discharge of water from a sediment basin, including water pH and suspended solids.</p> <ul style="list-style-type: none"> • Water quality monitoring at the nominated monitoring stations must be carried out monthly and following significant rainfall (>25mm in 72hrs). <p>The parameters to be tested for waters collected at monitoring stations must include: temperature, dissolved oxygen, pH, specific conductance, salinity, turbidity, suspended solids, and litter.</p> <p>Note that additional water quality monitoring maybe required if the WQOs are not being met.</p> |
| Auditing: | ESCP reviews are to be carried out on a monthly basis to assess the implementation strategy. A checklist is to be completed which assesses the strategies listed above. |
| Identification of Incident or Failure: | <p>Non-compliance with agreed performance criteria will be identified by:</p> <ol style="list-style-type: none"> 1. Visual inspections identifying: <ul style="list-style-type: none"> • build-up of sediment off the site; • excessive sediment build-up on the site; • excessive erosion on the site; • release of construction material from the site; • poor vegetation establishment; • poorly maintained, damaged or failed ESC devices. 2. Deteriorated water quality identified by the Environmental Consultant as being attributable to the construction activities. |

| | |
|----------------------------------|--|
| <p>Corrective Action:</p> | <p>After any identification of incident or failure, the source/cause is to be immediately located and the following measures implemented:</p> <ul style="list-style-type: none"> • Build-up of sediment off the site – the material must be collected and disposed of in a manner that will not cause ongoing environmental nuisance or harm; then on-site ESC measures amended, where appropriate, to reduce the risk of further sedimentation. • Excessive sediment build-up on the site – collect and dispose of material, then amend up-slope drainage and/or erosion control measures as appropriate to reduce further occurrence. • Severe or excessive rill erosion – investigate cause, control up-slope water movement, re-profile surface, cover dispersive soils with a minimum 100mm layer of non-dispersive soil, and stabilise with erosion control blankets and vegetation as necessary. • Off-stream erosion – fill rills, vegetate and install velocity control measures. • In-stream erosion – consult appropriate hydraulic/waterway consultant for advice. • Release of construction material from the site – collected and disposed of in a manner that will not cause ongoing environmental nuisance or harm; then inspect litter and waste receptors. • Poor vegetation growth or soil coverage – plant new vegetation and/or mulch as required. Newly planted and previously planted areas may require supplementary watering and replanting. • Sediment fence failure – replace and monitor more frequently. Regular failures may mean that the sediment fence location, alignment or installation may need to be amended. <p>If the release of excessive sediment and/or other materials off the site occurs, or water quality monitoring indicates levels are not within the WQOs, clean up deposition, and inspect all control measures.</p> <p>If the release of excessive sediment and/or other materials off the site is identified during two consecutive site inspections, or water quality monitoring indicates levels not within the WQOs on two consecutive monthly tests, then review and revise the ESCP, or otherwise reduce the rate, extent and/or duration of soil exposure.</p> <p>If monitored levels within any sediment basin does not conform to the release criteria for:</p> <ul style="list-style-type: none"> • suspended solids – flocculate and retest; • pH – add acid if pH is too high, or add hydrated lime if pH is too low, and retest. |
| <p>Reporting:</p> | <p>Reports will be submitted monthly during the construction at each stage. The reporting will include:</p> <ul style="list-style-type: none"> • Construction Contractor site manager's report; and • Environmental Consultant's water quality monitoring report. <p>Reporting will conform to <i>[insert document]</i> and identify performance of the implementation strategy, monitoring, identification of incidents and failure, and necessary/adopted corrective action. Reports will be submitted to the owner (or their appointed representative) monthly for submission to <i>[insert name of regulatory authority]</i>.</p> |

Example A: Construction of University Accommodation Units

Site Description:

The site is covered with both native and non-native vegetation. The site receives flow from an 18ha catchment to the north-east. At present there exists minimal erosion on the site, however, the drainage gully has experienced some erosion as a result of recent developments within the catchment.

Downstream of the site the overland flow path develops into a creek with defined bed and banks. Base flow exists in this creek for a number of days following rain. The creek discharges into a tidal river that eventually discharges into a bay. There are no wetlands downstream of the creek. Both the creek and the river have recognised environmental values, and both have a high potential for rehabilitation.

The site is surrounded by medium density, private residential areas (north and east), University accommodation developments to the south and the main University campus to the west. A timber perimeter fence has already been constructed around the site.

The accommodation units will be constructed on a raised slab that will require little or no cut and fill earthworks.

Soils information:

Geotechnical investigations of the site reveal that the topsoil consists of a low fertility, non-dispersive, dark sandy loam with depths varying from 100 to 200mm.

Subsoils comprise a reddish clay loam, and are non-dispersive. From geotechnical findings for the subsoil: 20% finer than 0.02mm, low permeability, medium to high erodibility (assume K-factor = 0.03).

Some rock outcrops do exist, however no groundwater problems are anticipated.

Explanatory notes:

1. The attached plans are representative of the type of information that could be supplied in the Supporting Documentation to describe the construction sequence and the options considered for the development of the site's major sediment trap. Small A4-plans like these that complement the main A1-ESCP can be an effective way of communicating with construction personnel.
2. One of the principle aims on this site is to minimise the loss of existing vegetation, thus allowing the accommodation units to integrate into the existing environment. Thus, considerable effort has been placed on minimising site disturbance.
3. Figure D3 (Dwg No. A-001) demonstrates the importance of the early installation of the main pipeline to divert external catchment through the site prior to major land clearing and earthworks.
4. The entry/exit point, stockpile area and the temporary access road are located in a position to minimise overall site disturbance.
5. The site office is located close to the site entry point and up-slope of the stockpile area thus reducing the potential for sediment-laden water to flow past the site office and car park.
6. The temporary watercourse crossing (TCC-1) will consist of a length of steel pipe installed under the access roadway to allow drainage of the upper catchment to pass under the roadway.
7. All sediment fences that are **not** installed along a line of constant elevation will contain "returns" at a spacing not exceeding 20m.

8. Figure D4 (Dwg A-002) demonstrates Option 1 for the installation of a sediment basin. This option would result in major land clearing down-slope of the permanent site entry road. Due to space limitations, the sediment basin's embankment would need to be formed from gabions. A gabion outlet would be expensive to build and would reduce the basin's ability to control turbidity levels (ie the basin would only represent a Type 2 sediment trap). This option may also not provide the required basin surface area. In this option, a temporary sediment fence (SF-1) would have initially been installed instead of the proposed sediment weir (SW-1).
9. Figure D5 (Dwg A-003) demonstrates an alternative sediment basin (Option 2). This option uses the construction of the raised internal road to form the main embankment. Drainage pit 3/1 would act as the riser pipe outlet structure if a Type C (dry) sediment basin is required, otherwise the pit will be sealed to allow the operation of a Type F (wet) basin. The sediment weir (SW-1) would collect and treat any runoff from the lower end of the site that cannot be directed into the sediment basin. The efficiency of this sediment trap (SW-1) would be significantly reduced by the inflow of water from the external catchment discharging from the main pipeline. A sediment weir has been chosen because of its ability to withstand concentrated flow discharged from the pipeline. For the purpose of this example, Option 2 was chosen.
10. Figure D6 (Dwg A-004) demonstrates a multiple sediment basin option (Option 3). Sediment basin SB-2 would be sized in accordance with Option 2 above. Sediment basin SB-3 would be sized to treat runoff only from the lower end of the site. The main pipeline would be temporarily extended through SB-3. The cost of constructing Option 3 would be significant; however, it would provide the greatest opportunity to reduce turbidity levels within the site runoff. In this option, a sediment fence (SF-1) would have initially been installed instead of the proposed sediment weir (SW-1).
11. Sediment fence SF-3 would be optional depending on the risk of failure of catch drain CD-1.
12. It is assumed in this example that sediment fences SF-4 and SF-5 will be installed up against the existing property boundary fence and that this fence is strong enough to take the extra loading. If no property fence existed, then the sediment fences should be relocated along the lower edge of the proposed land clearing. If high sediment runoff rates were expected from the building of the accommodation units, then locating the sediment fences closer to the building works (rather than along the property boundary) would be preferable to reduce sediment deposition within the retained bushland.
13. All stormwater gully inlets will be sealed to prevent inflow until the site is stabilised.
14. During construction of the internal roads, the flow diversion bank (DB-1) would be formed as a temporary bank at the end of each day's work and prior to storm events, to direct runoff from the roadway into the sediment basin. After completion of the road works, the flow diversion bank would be constructed as a temporary speed control device to continue to deflect runoff into the basin. Thus the flow diversion bank would be formed in a layer of heavy-duty filter cloth to assist in its eventual removal from the roadway.
15. Sediment fences SF-6 and SF-7 are installed prior to construction of Units F and G to both minimise sediment runoff into the retained bushland between the units and the down-slope sediment weir, and to trap sediment as close to its source as practical. In this case, trapping sediment as close to its source as practical is important given the limited ability of the sediment weir to control turbidity levels. Of course each site is different and thus the need for these two sediment fences would depend on actual site conditions.

Installation sequence:

The following installation sequence is based on sediment basin Option 2 as shown in Figure D5 (Drawing A-003).

Table D2 – ESC installation sequence (Example A)

| Item | Dwg | Installed | Removed |
|--|------------|--|---|
| Mark out initial limits of disturbance | A-001 | Prior to site disturbance | |
| Exit-1 | A-001 | Day 1 | When permanent internal roads are sealed |
| Clear access track to SF-1 | A-001 | After installing Exit-1 | |
| SW-1 | A-001 | After access track establishment. | After installing SB-1 |
| TCC-1 | A-001 | After SW-1 | When constructing the permanent driveway |
| Clear site office, pipeline and stockpile area | A-001 | After SW-1 | |
| SF-2 | A-001 | After clearing area | After site stabilisation or as necessary to build Units A1-A4 |
| Install site office | A-001 | After clearing area | |
| Install pipeline No. 1 | A-001 | After SW-1 | |
| SB-2 | A-003 | After installing the main pipeline | After stabilising the site following completion of all Units |
| SF-3 | A-003 | After SB-2 | After site stabilisation |
| SF-4 | A-003 | After SB-2 | After site stabilisation |
| SF-5 | A-003 | After SB-2 | After site stabilisation |
| CD-1 | A-003 | After SF-3 | |
| Roads and drainage | A-003 | After CD-1 | |
| DB-1 | A-003 | At end of each day and prior to storms | After site stabilisation |
| Bank stabilisation | A-003 | Upon completion of earthworks | |
| SF-6 | A-005 | Before constructing Unit G | After site stabilisation |
| SF-7 | A-005 | Before constructing Unit F | After site stabilisation |

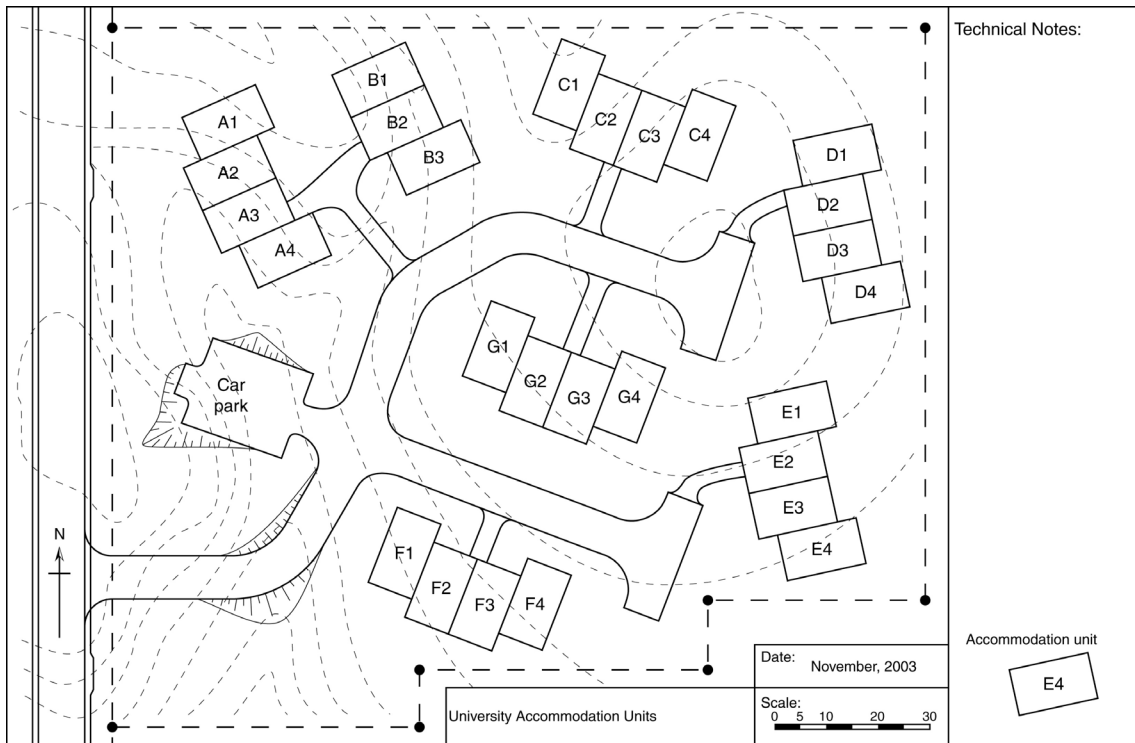

Figure D1 – Development proposal

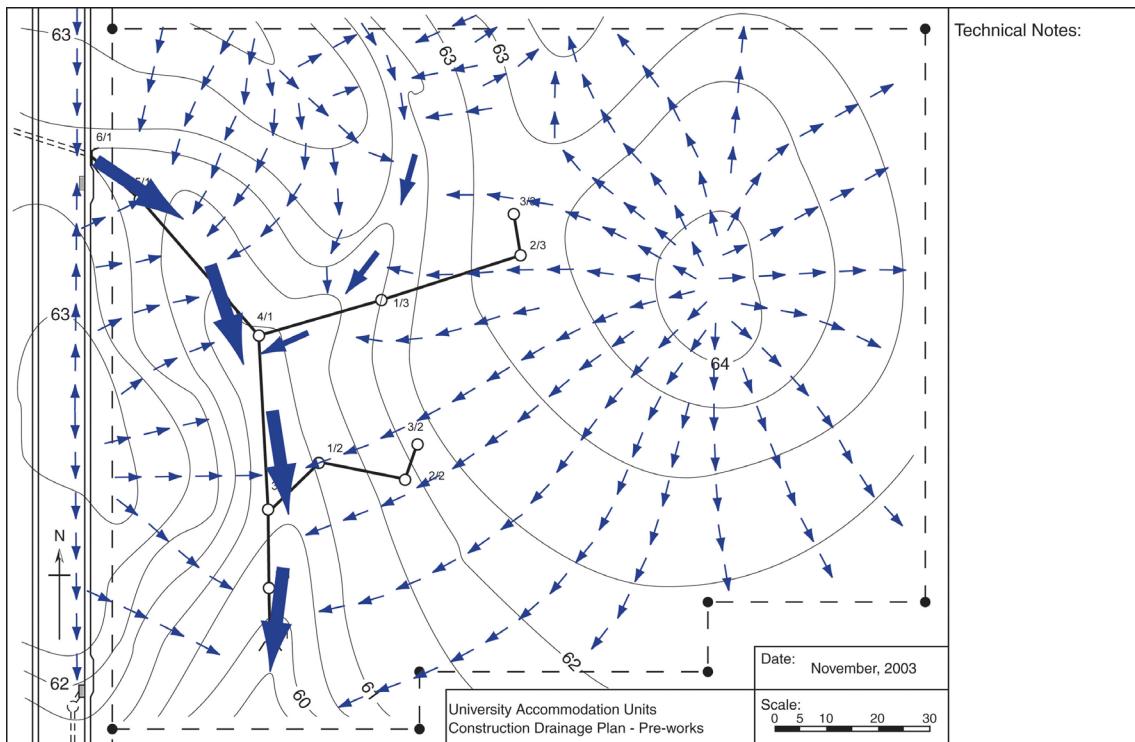

Figure D2 – Site drainage prior to development

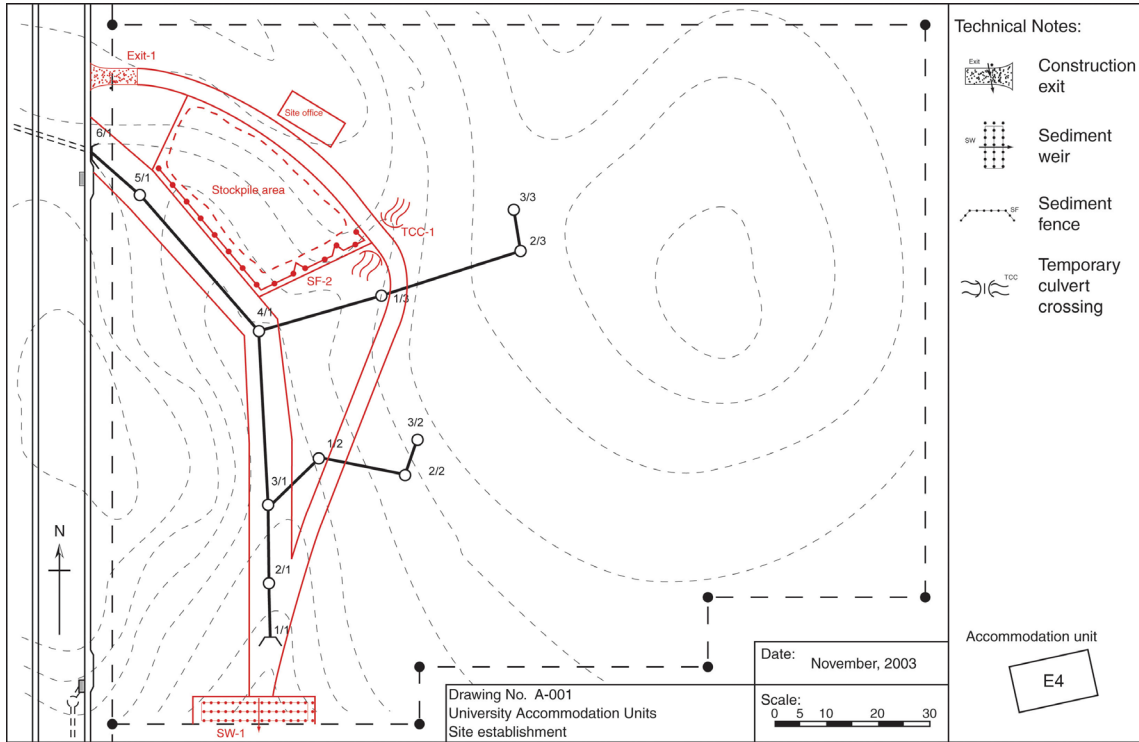

Figure D3 – Site establishment and drainage works

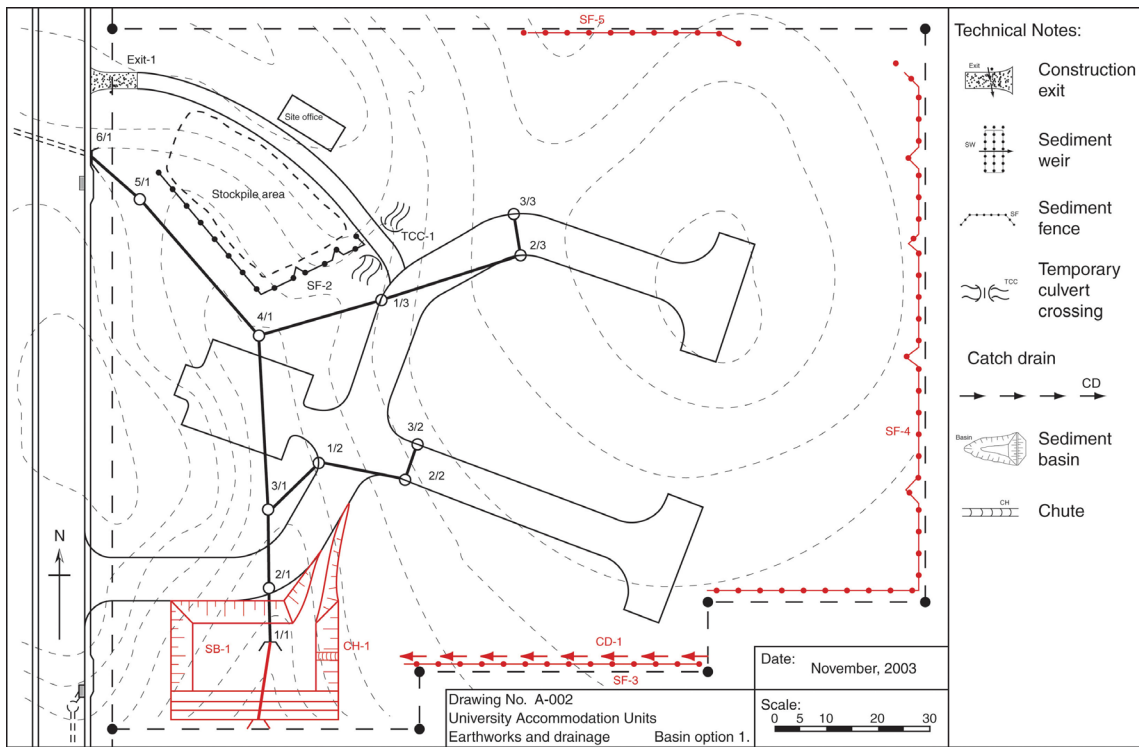

Figure D4 – Option 1 for establishment of a *Sediment Basin*

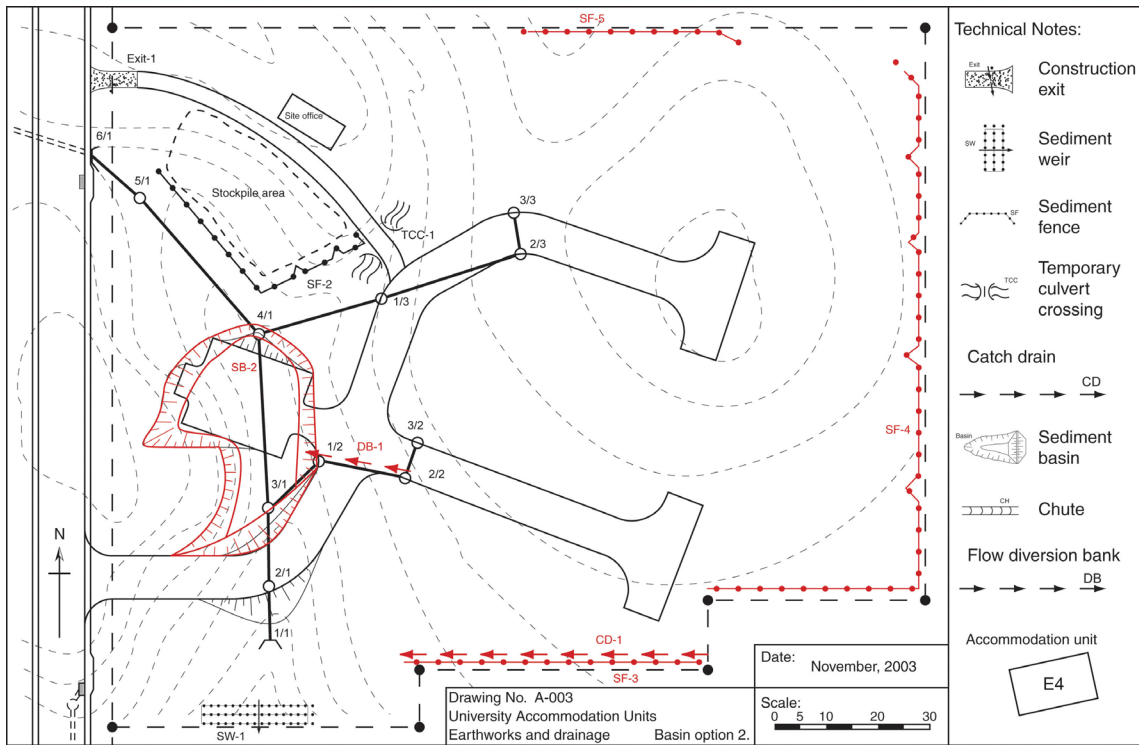

Figure D5 – Option 2 for establishment of a *Sediment Basin*

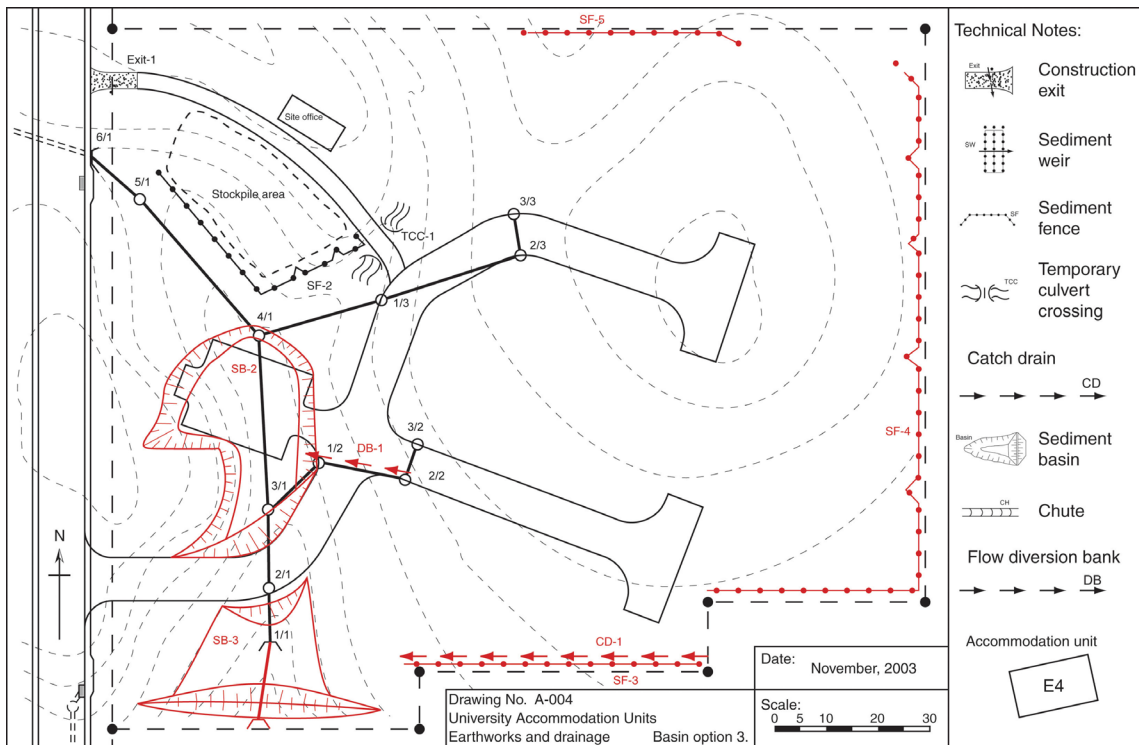

Figure D6 – Option 3 for establishment of a *Sediment Basin*

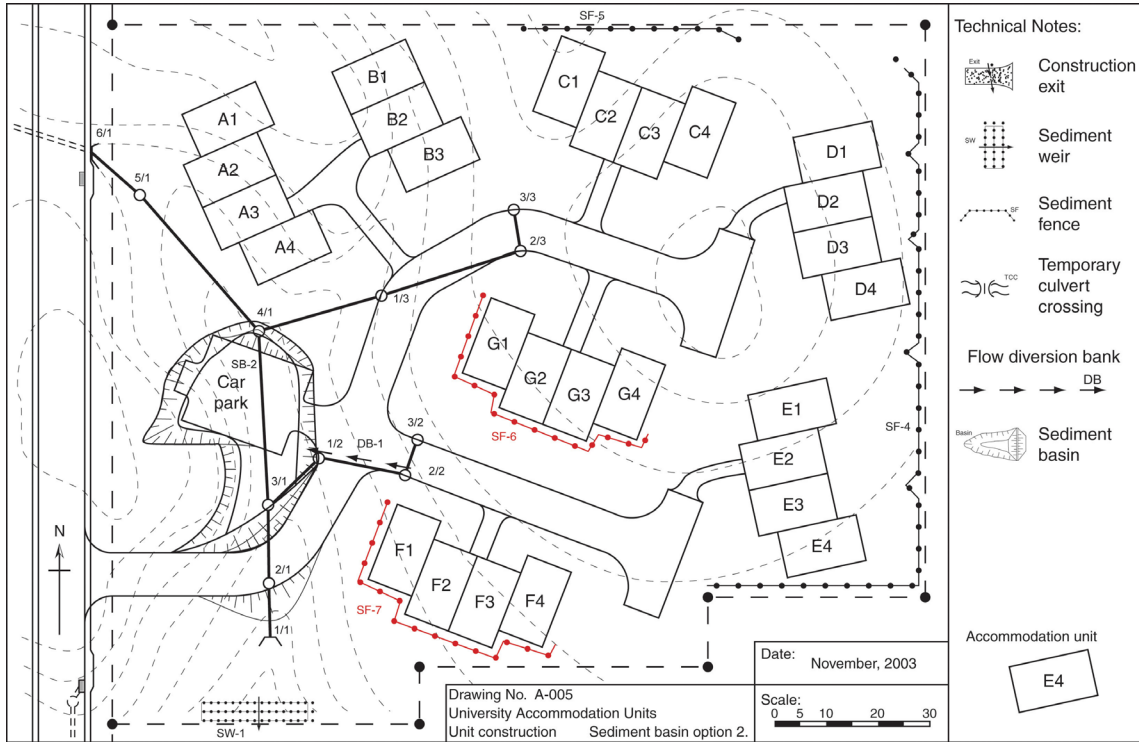

Figure D7 – Construction of accommodation units

Example B: Residential subdivision

Site description:

The site is covered with native and non-native vegetation and there is no evidence of significant erosion under present conditions. Significant weeding and revegetation with native species is to be carried out within the park contribution as part of the subdivisional works.

There is no external surface water entering the site. All drainage from the existing road (shown on the far left of the plan) is directed away from the site.

Existing residential developments are located east, north, and south of the subdivision. The land south the proposed park is a bushland reserve containing a highly valued wetland.

Soils:

Subsoils consist of a reddish clayey loam (30% finer than 0.02mm) with low permeability and a medium erodibility factor (assume K-factor = 0.03). Subsoils over most of the site are not considered dispersive.

Topsoils are dark in colour with depths varying from 100 to 200mm and are non-dispersive. Groundwater problems and rock outcrops are not expected.

Local Environment:

The creek south of the site has a history of minor disturbance, however, aquatic life still exists within near permanent pools. Base flow only exists for a few days after significant rain.

The creek passes through a wetland before entering into a tidal river that discharges directly into the ocean. The creek and river have recognised environmental values and have a high potential for rehabilitation.

A small constructed lake exists within the residential development to the east of the property.

Explanatory notes:

1. Figure D8 (Dwg B-001) demonstrates treatment Option 1 based on the assumption that partial clearing of the park contribution is allowable, thus allowing construction of a sediment basin within this area.
2. Both the site office and stockpile area have been located within the sub-catchment that drains to the sediment basin, thus maximising retention of any sediment runoff.
3. Catch drain (CD-1) will be lined with filter cloth to minimise soil erosion.
4. Catch drains (CD-2 & 3) will be lined with turf and will remain as permanent stormwater drains.
5. All sediment fences that are **not** installed along a line of constant elevation will contain "returns" at a spacing not exceeding 20m.
6. Entry/exit pads (Exit-1 & -2) exist only until the internal roads are sealed.
7. The Type F (wet) sediment basin SB-1 consists of an earth embankment with an emergency rock mattress spillway (CH-1) constructed in virgin soil. Downstream sediment controls would be required during construction and de-commissioning of the sediment basin.

8. An additional sediment fence may need to be installed between catch drain (CD-3) and the existing property fence if there is the likelihood that the catch drain could be damaged or partially blocked with sediment, thus allowing sediment-laden water to spill directly into the adjacent residential properties.
9. A sediment trench (SS-1) is used instead of a sediment fence or sediment weir because of the need to minimise turbid water flowing into the downstream lake and because the mild profile of the valley would make it very difficult to pond water above natural ground level. In an extreme case, a Type F sediment basin would need to be constructed within the property allotment to protect the downstream lake.
10. Stormwater gully inlets on the internal roadway (excluding adjacent Exit-2) will remain open following sealing of the road surface to direct any sediment-laden runoff to the sediment basin. On-grade kerb inlet traps placed adjacent to Exit-2.
11. Permanent outlet stabilisation works that are required downstream of the stormwater pipes are not shown or discussed as part of this example.
12. Figure D9 (Dwg B-002) demonstrates a second option (Option 2) which may be considered if conditions did not allow construction of the sediment basin within the proposed parkland. In general this option would be considered inferior to Option 1 because of its limited ability to control turbidity levels.
13. In Option 2, sediment weirs (SW-1 & 2) are used because they would be able to withstand the concentrated flows and would require the least amount of land clearing in order to allow their installation.
14. Where conditions allow, sediment weir (SW-1) could be replaced with a rock filter dam, sediment trench or possibly a sediment fence. The final choice of treatment option would depend on the degree of land clearing on the up-slope lots and whether or not filling was required on these lots to facilitate slab-on-ground construction.

Installation sequence:

The following installation sequence is based on sediment basin Option 1 as shown in Figure D8 (Dwg B-001).

Table D3 – ESC installation sequence (Example B)

| Item | Dwg | Installed | Removed |
|--|-------|------------------------------|--------------------------------|
| Mark limits of disturbance | B-001 | Prior to site disturbance | |
| Exit-1 | B-001 | Day 1 | When internal roads are sealed |
| Exit-2 | B-001 | Day 1 | When internal roads are sealed |
| Site office | B-001 | Day 1 | |
| SF-1 | B-001 | Prior to land clearing | After site stabilisation |
| SF-2 | B-001 | Prior to land clearing | After site stabilisation |
| SF-3 | B-001 | Temporary fence | After stabilisation of SB-1 |
| SB-1 | B-001 | After SF-3 | After site stabilisation |
| CH-1 | B-001 | During construction of SB-1 | During removal of SB-1 |
| Clearing basin settling zone | B-001 | After forming the embankment | |
| CD-1 | B-001 | After construction of SB-1 | After site stabilisation |
| SS-1 | B-001 | Prior to land clearing | After site stabilisation |
| CD-2 | B-001 | After construction of SS-1 | |
| CD-3 | B-001 | After construction of SS-1 | |
| Land clearing drainage and road construction | | | |
| SF-4 | B-001 | After land clearing | After site stabilisation |

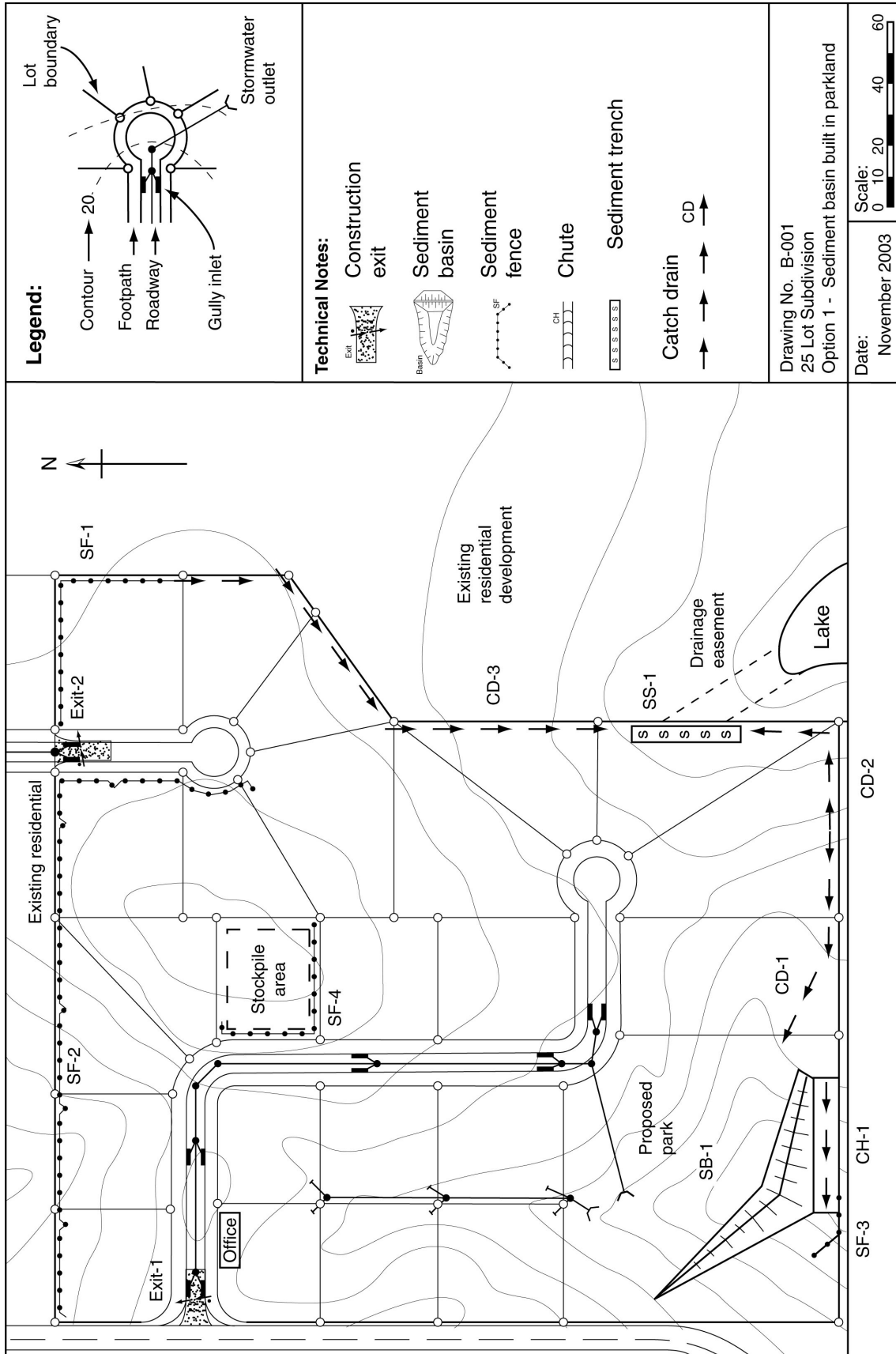

Figure D8 – Option 1 (Drawing B-001)

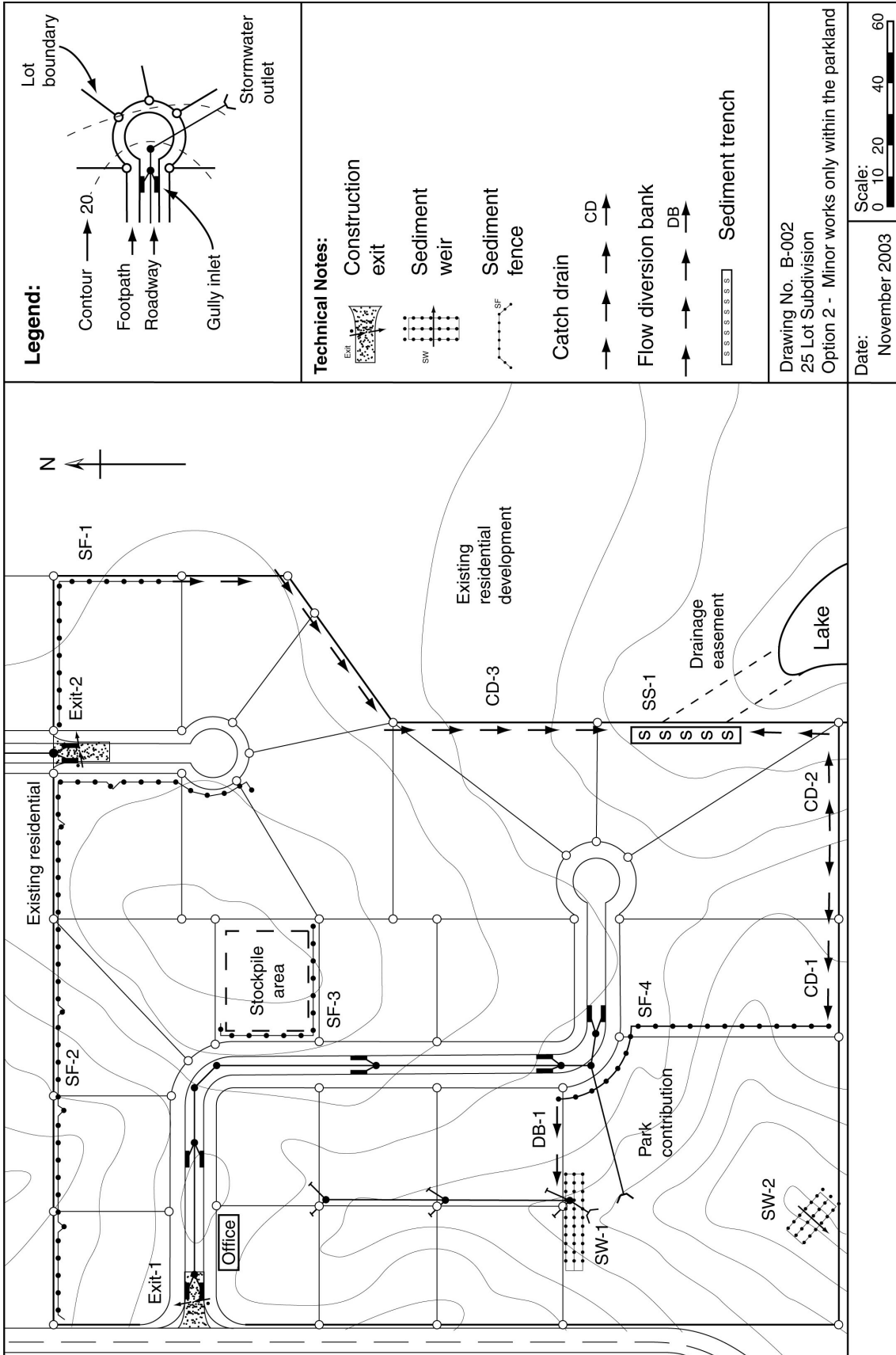

Figure D9 – Option 2 (Drawing B-002)

Example C: Road construction

Site description:

Heavy construction access is available from the intersection of Roads No. 1 and 2. Light vehicle access is available from Road No. 3.

Significant erosion exists at the temporary stormwater outlets located near road chainages 250.00, 450.00 and 610.00 (Road No. 4). High sediment runoff is expected from the adjacent subdivision north of the road as it is still in its construction phase. The stormwater outlets at chainages 250.00 and 610.00 are to be extended to the main outlet at chainage 450.00 during construction of the road.

Table D4 – Final road elevation

| Description | Chainage (m) | Elevation (m) AHD |
|--------------------------|--------------|-------------------|
| Crest | 130.00 | 31.000 |
| | 210.00 | 25.000 |
| near 450mm outlet | 290.00 | 18.000 |
| 1800mm stormwater outlet | 450.00 | 13.000 |
| 450mm stormwater outlet | 610.00 | 20.000 |

Soil type:

The soil is a moderately erodible clayey loam between chainages 0.00 to 450.00, varying to a highly erodible sandy loam between chainages 450.00 and 610.00.

Vegetation protection:

The site is covered with bushland from the creek to the back of the residential properties. The land between the road reserve and the creek is bushland reserve and damage to vegetation in this area is to be avoided. The trees of greatest value are adjacent to the creek and the small, unnamed tributary that crosses the road reserve near chainage 450.00.

Watercourse condition:

Gully erosion and significant sedimentation currently exists within the unnamed tributary. The creek catchment is currently experiencing significant urbanisation and the creek currently has poor water quality including high turbidity. The creek is considered to have high environmental values with a high potential for future rehabilitation.

Explanatory notes:

1. The stabilised construction entrance (Exit-1 shown in Dwg C-002 & 4) consists of a rock pad with flow diversion bank installed to direct sediment-laden water into sediment fence (SF-2). Entry/exit pad exists only until the road is sealed.
2. Sediment fences (SF-1, 2, 3, 5 & 6) will be formed using non-woven sediment fence fabric. All sediment fences that are **not** installed along a line of constant elevation will contain "returns" at a spacing not exceeding 20m.
3. Sediment weir (SW-1) is used in preference to a sediment fence spill-through weir because of the potential high flows discharged from the stormwater pipe (chainage 250.00) prior to the pipe being extended to chainage 450.00.
4. The topsoil stockpile will be protected from any discharges from the stormwater pipe (chainage 610.00) using a flow diversion bank. This bank will discharge water around sediment fence (SF-4).

5. Catch drain (CD-5) may need to be supplemented with a sediment fence if site conditions are likely to cause sediment-laden runoff to be discharged from the site. In this case a catch drain has been recommended instead of a sediment fence because the road alignment runs almost perpendicular to the contours and thus once the topsoil is stripped from the site any sediment-laden runoff will flow down the road and not off the site.
6. Catch drains (CD-6 & CD-7) are created by forming a windrow on the edge of the road earthworks. Flow velocities down these catch drains will be controlled by installing sandbag check dams at the end of each day's work and prior to storm events.
7. Level spreader (LS-1) releases only "clean" water into the bushland.
8. One of the primary aims of the ESCP is to allow the early installation of the stormwater pipe extension at chainage 450.00. Only after this pipe is extended and the two sediment basins are constructed will general clearing of the road reserve be allowed to commence.
9. Sediment fence (SF-5) is only operational during installation of the stormwater pipe.
10. Due to the requirement to fully contain all works within the road reserve, the two sediment basins (SB-1 and SB-2, shown in Dwg C-003) will be formed within the road reserve. This will mean that these sediment basins will slowly be backfilled as the road earthworks are being completed. The cut and fill earthworks will progress such that the two sediment basins will be fully operational for as long as practical.
11. Where practical, the sediment basins should be located down-slope of the roadway to allow their operation during the full construction phase. However, this will usually require early ESC planning to allow appropriate negotiations to occur with the adjacent landowner. It is also noted that placing the sediment basins outside the roadway will require additional vegetation clearing.
12. Erosion control measures will become critical towards the end of the earthworks phase when the sediment control measures become less efficient. Thus all earth batters will be covered with erosion control blankets immediately after earthworks are completed on each batter face. In addition, all footpath areas that are to be grassed will be turfed rather than seeded.
13. An earth bridge will need to be formed over the extended stormwater pipe to allow movement of construction vehicles (Dwg C-003).
14. The sediment fence spill-through weir (OS-1) will be set just 150mm below the normal crest of the sediment fence. The whole fence will also be braced to reduce the risk of hydraulic damage.
15. As the cut and fill earthworks are being completed near sediment basin (SB-2), catch drain (CD-5) will eventually be redirected to discharge "dirty" water into sediment fence (SF-6) as shown in Dwg C-005.

Installation sequence:**Table D5 – ESC installation sequence (Example C)**

| Item | Dwg | Installed | Removed |
|--|-------|---|---|
| Mark out initial limits of disturbance | C-001 | Prior to site disturbance | |
| Exit-1 | C-002 | Day 1 | When permanent internal roads are sealed |
| SF-1 | C-004 | After Exit-1 | After stabilisation of chainage 0.00 to 120.00 |
| SF-2 | C-004 | After Exit-1 | After stabilisation of chainage 0.00 to 120.00 |
| Clear access track along the alignment of CD-1, CD-4, SF-3 and CD-5 | | | |
| SW-1 | C-002 | After SF-1 & SF-2 | After stabilisation of the fill embankment between chainage 200.00 and 330.00 |
| SF-3 | C-002 | After SW-1 | After stabilisation of the fill embankment between chainage 200.00 and 450.00 |
| OS-1 | C-002 | During installation of SF-3 | During removal of SF-3 |
| SF-5 | C-003 | After SF-3 | After installation of stormwater pipe chainage 450.00 |
| SF-6 | C-003 | After SF-5 | After stabilisation of adjacent fill embankment |
| CD-1 | C-002 | After SF-3 | |
| CD-4 | C-002 | After SF-3 | |
| LS-1 | C-002 | After CD-4 | |
| CD-2 | C-002 | After SF-3 | |
| CD-3 | C-002 | After SF-3 | |
| Clear area around stormwater pipe at chainage 450.00 and SB-1 and SB-2 | | | |
| Install stormwater pipe extension at chainage 450.00 | C-003 | Prior to general clearing of the road reserve | |
| SB-1 | C-003 | After installation of pipe | Decommission at end of road earthworks |
| SB-2 | C-003 | After installation of pipe | Decommission at end of road earthworks |
| CD-5 | C-002 | After SB-2 | |
| Clearing of road reserve and form earth bridge of the stormwater pipe | | | |
| SF-4 | C-002 | During road clearing | |
| CD-6 | C-002 | During road construction | Sealing of road |
| CD-7 | C-002 | During road construction | Sealing of road |

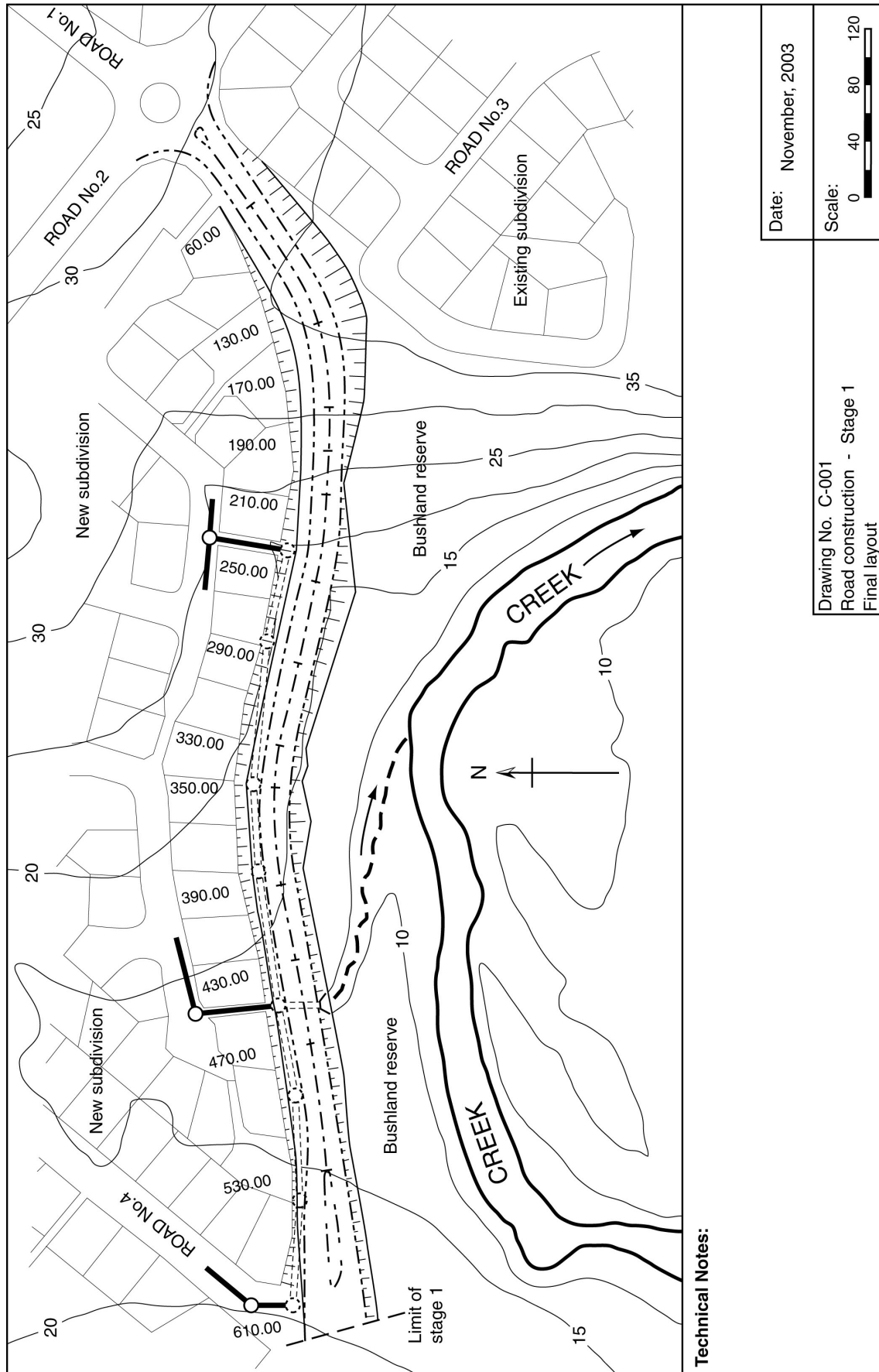

Figure D10 – Final road layout (Dwg C-001)

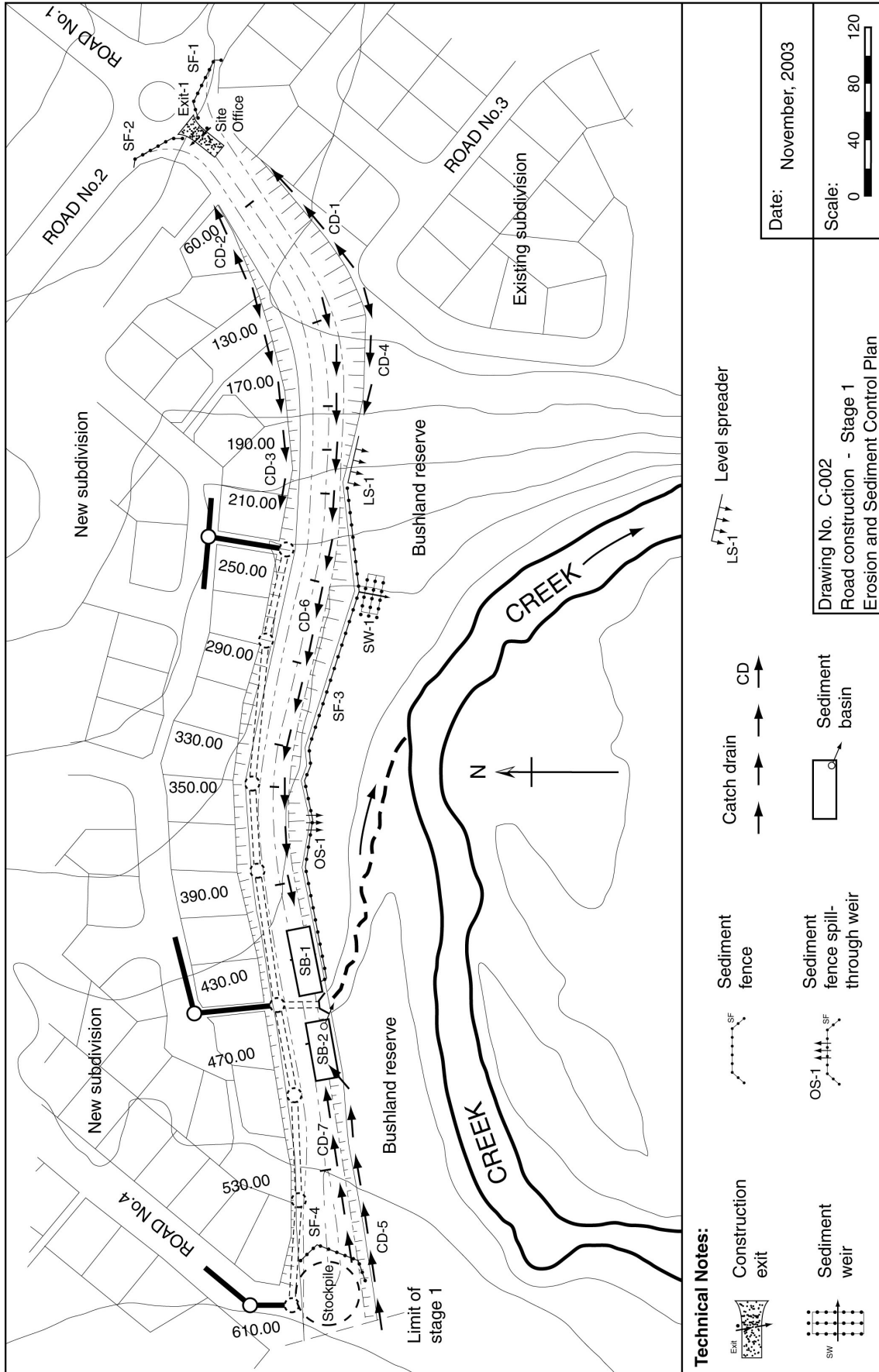

Figure D11 – Erosion and Sediment Control Plan (Dwg C-002)

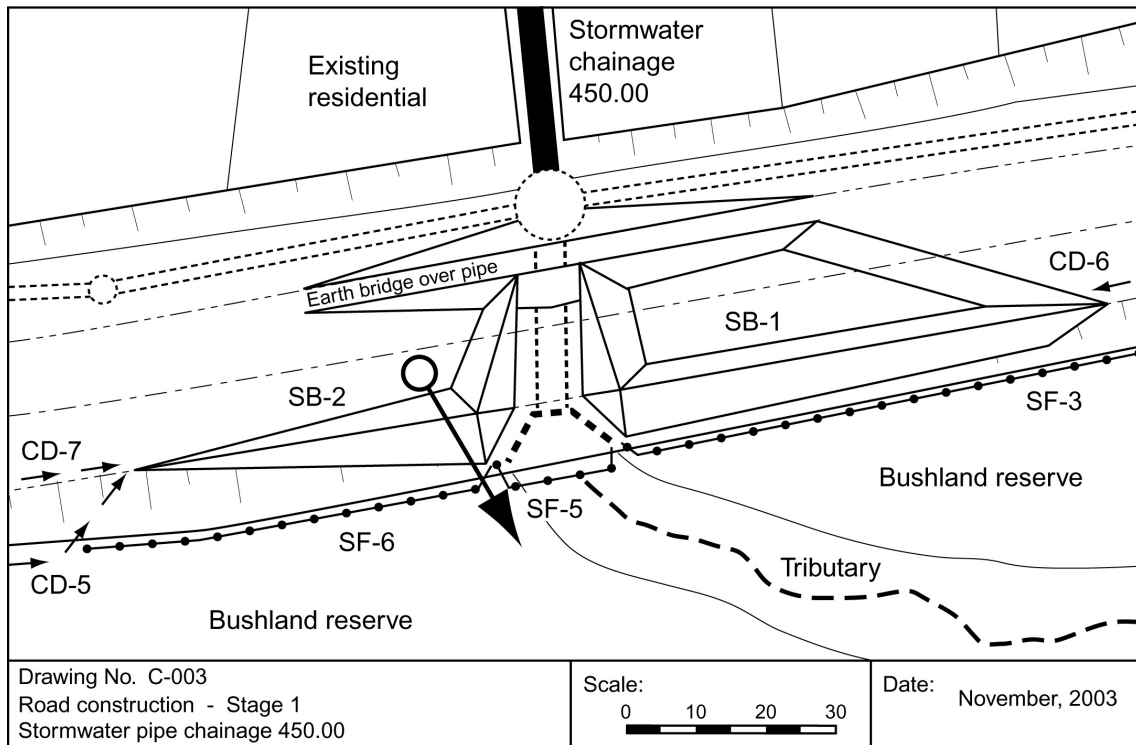

Figure D12 – Details of sediment basins (Dwg C-003)

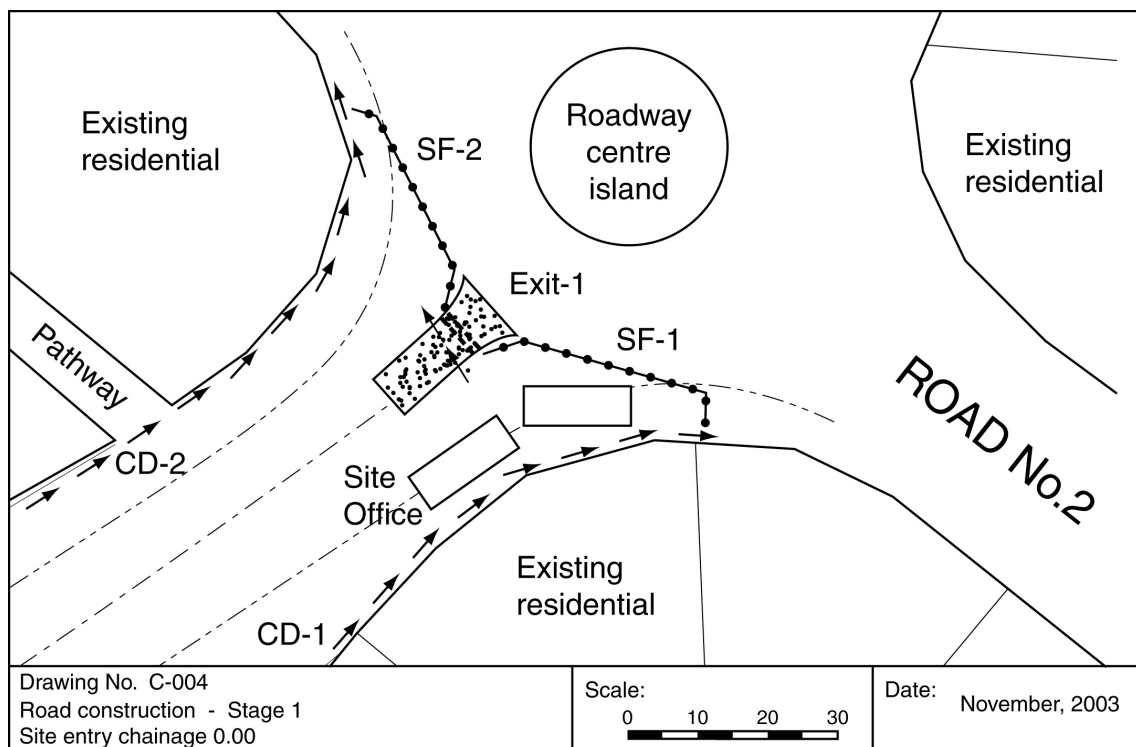

Figure D13 – Details of road intersection (Dwg C-004)

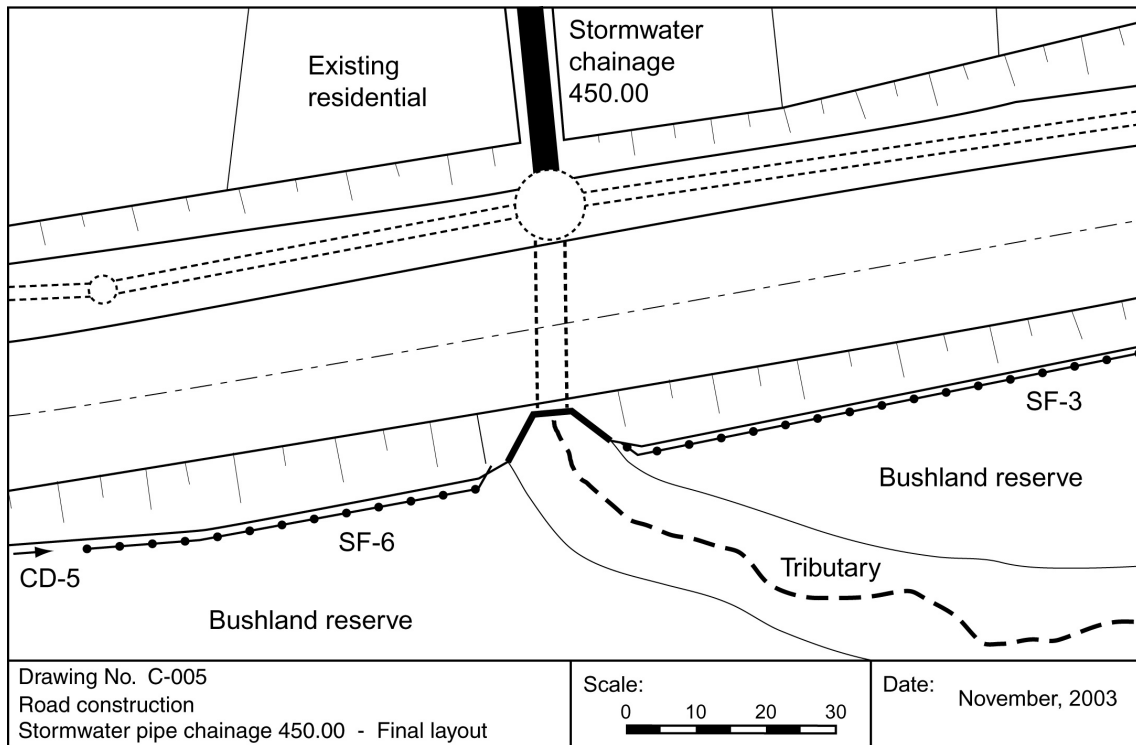

Figure D14 – Final road layout at chainage 450.00 (Dwg C-005)

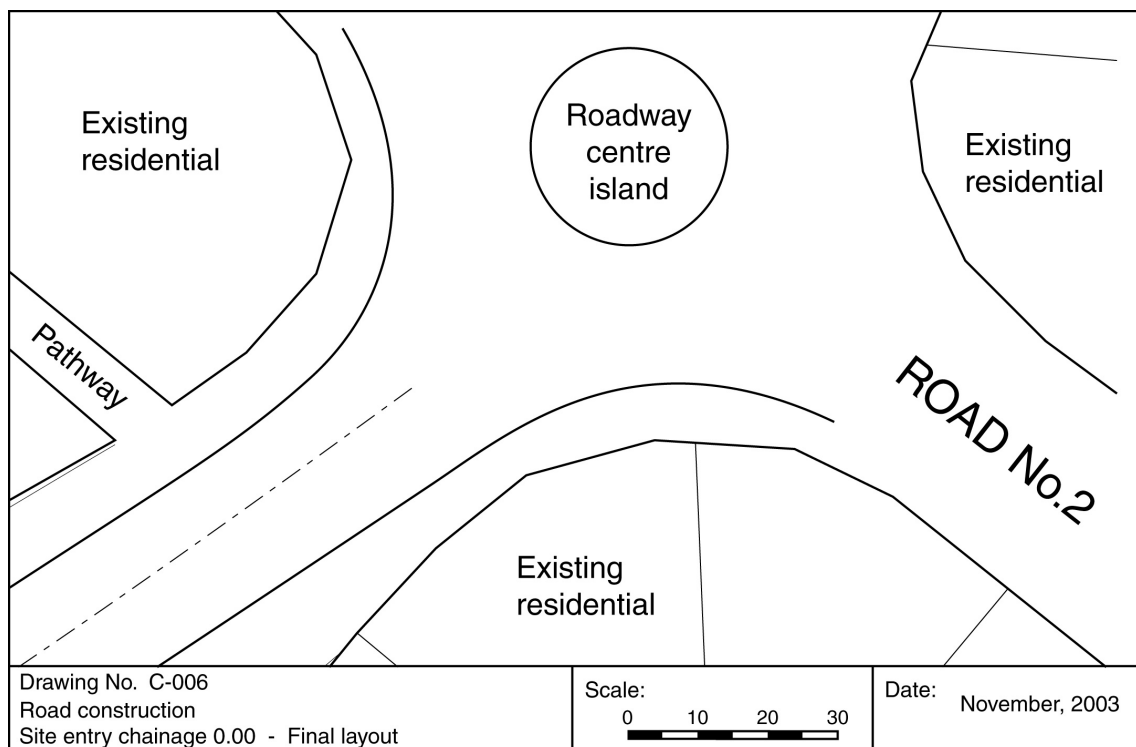

Figure D15 – Final road layout at intersection (Dwg C-006)

Appendix E

Soil loss estimation

This appendix provides information on the application of soil loss estimation procedures, specifically the Revised Universal Soil Loss Equation (RUSLE), as an “indicator tool” used in the determination of the sediment control standard. Its function within this document is both prescriptive and educational.

*The appendix is **not** presented as a means of determining accurate estimates of soil loss rates. Reliable prediction of soil loss rates should only be performed by suitably training professionals experienced in the use of such analytical methods.*

Within the context of this appendix, the term “erosion model” refers to both empirical soil loss equations and numerical models.

E1 Introduction

Considerable time and effort has been spent by soil scientists and agricultural engineers on the development of various soil loss estimation procedures. In the hands of experienced professionals these procedures can provide valuable information. However, in the hands of an inexperienced operator, even the simplest soil loss equation can produce very misleading results.

In civil construction projects, soil loss estimation is likely to be used for the following activities:

- assessment of the potential erosion hazard associated with a given project;
- identification of high-risk construction projects during the planning and/or design phase;
- the sizing of the “sediment storage volume” of *Sediment Basins*;
- assessment of the relative performance of alternative soil conservation practices, Erosion and Sediment Control procedures or construction programs.

Erosion models vary enormously from the simplest empirical equation to the most complicated numerical models. The Universal Soil Loss Equation (USLE: Wischmeier & Smith, 1978), and subsequently, the Revised USLE (RUSLE: Renard et al., 1991, 1997) are intended to consider annual averages of sheet and rill erosion from hill slopes. In comparison, various Modified USLE (MUSLE: Williams & Berndt, 1977) formulations consider single events, and can be run for long periods of rainfall record to give daily information on soil erosion.

Erosion models are typically most valuable when applied to the management of agricultural and mining practices where large areas of uniform “sheet” flow are expected.

Most models do consider only soil erosion rather than sedimentation, though the catchment form of WEPP (Lane & Nearing, 1989) can consider sedimentation processes within channels and impoundments.

E2 Potential problems associated with the inappropriate use of soil loss models

Operators of these soil loss models should be aware of the potential problems that can occur when applying soil loss models to a specific site, such as those discussed below.

- (a) Most models predict only rill and inter-rill erosion, requiring a separate assessment to be made of likely deposition and erosion resulting from concentrated flows.
- (b) Most of the commonly used soil loss models can not accurately assess the sediment retention mechanics of a construction site (i.e. the efficiency of the adopted sediment control measures). Thus these models can only be used to assess the potential “erosion risk” rather than the potential “environmental hazard”.
- (c) Soil loss equations such as RUSLE do not distinguish between the discharge of coarse sediment and the discharge of fine sediment. Thus these models may not provide an appropriate indication of the potential environmental hazard to those receiving environments primarily susceptible to the harm caused by clay-sized particles.
- (d) If an **annual** erosivity factor is used within the equation, then the analysis is unlikely to give an appropriate indication of the erosion risk associated with a specific land disturbance that is expected to occur over a time period less than 1 year.
- (e) Most simplified soil loss models only allow for the assessment of alternative drainage and erosion control options. An analysis of the benefits of alternative sediment control options usually requires the use of more sophisticated numerical models.
- (f) Most soil loss models are best suited to the assessment of drainage practices on broad-acre land disturbances incorporating relatively uniform areas of “sheet” flow. On civil construction sites, however, drainage activities are more commonly associated with small, highly variable sub-catchments incorporating significant areas of concentrated flow. In such complex catchments, the appropriate application of soil loss models usually requires an equal degree of complexity within the model’s formulation and operation.
- (g) Soil loss equations such as RUSLE can provide a reasonable assessment of sediment flow into a *Sediment Basin* under average rainfall conditions, but actual rainfall during short-term construction activities can be significantly different from average rainfall conditions. Given the inaccuracy of most soil loss models when applied to complicated civil construction sites, and the high variability of possible weather conditions over short construction periods, it is unlikely that the use of complex and time-consuming soil loss models to estimate the required “sediment storage volume” of *Sediment Basins* can be justified.
- (h) The USLE and RUSLE equations were derived using data from a range of sites dominated by medium-textured soils, thus requiring special care when applied to soils at either end of the texture range.

E3 Revised Universal Soil Loss Equation (RUSLE)

E3.1 Introduction

The Revised Universal Soil Loss Equation (RUSLE) is commonly used to predict long-time *average* soil loss rates resulting from sheet and rill flow (not wind or gully erosion). A detailed discussion on the use of RUSLE is provided in Landcom (2004).

Soil losses calculated by RUSLE are considered best estimates based on long-term average rainfall records. They are not absolute values, nor an estimate of soil losses within a given year or given time period. The equation does not attempt to predict sediment deposition rates or sediment transportation down-slope of sediment control measures.

RUSLE calculates annual erosion rates based on:

$$A = R \cdot K \cdot LS \cdot C \cdot P$$

where:

- A = annual soil loss due to erosion [t/ha/yr]
- R = rainfall erosivity factor
- K = soil erodibility factor
- LS = topographic factor derived from slope length and slope gradient
- C = cover and management factor
- P = erosion control practice factor

The main limitations of RUSLE as a soil loss model are (Landcom, 2004):

- predicts soil erosion only, not sediment retention;
- addresses sheet and rill erosion on short slopes (< 300 m) only, not erosion caused by concentrated flow such as flow down a table drain;
- predicts average annual soil loss, not the soil loss from a “design storm” event;
- it does not address the effects of soil dispersibility

Within the context of this appendix, the RUSLE soil loss equation is primarily used as an “indicator” of potential soil loss for the purpose of setting sediment control standards. It is not the intention of this appendix to provide such information as to allow the RUSLE equation to be used for the accurate assessment of soil loss rates. If such analysis is required, then appropriately trained operators should seek model parameters, specifically soil erodibility (K) factors, from specialist publications such as Rosewell & Loch (2002), Loch & Rosewell (1992) and Loch et al. (1998).

E3.2 R-factor

Monthly and annual rainfall erosivity factors (R) may be determined from Tables E1 and E2. In locations where it is considered inappropriate to interpolate values from Tables E1 or E2, the annual erosivity factor may be determined from the following formula:

$$R = 164.74 (1.1177)^S S^{0.6444}$$

where, S is the 2 year ARI, 6 hour rainfall event [mm] (Rosewell & Turner, 1992). Rainfall erosivity factors for NSW are also provided in Landcom (2004).

Table E1 – Monthly and annual rainfall erosivity (R-factor) values

| Location | Jan | Feb | Mar | Apr | May | Jun | Jul | Aug | Sep | Oct | Nov | Dec | Yearly |
|----------------------------|------|------|------|------|------|------|------|------|------|------|------|------|--------------|
| Queensland | | | | | | | | | | | | | |
| Weipa | 1286 | 1334 | 899 | 215 | 19.1 | 4.8 | 0.0 | 0.0 | 9.6 | 52.6 | 244 | 722 | 4786 |
| Cairns | 4727 | 5186 | 4516 | 1320 | 402 | 134 | 57.4 | 76.5 | 115 | 191 | 727 | 1665 | 19118 |
| Normanton | 1539 | 1308 | 758 | 104 | 14.1 | 23.5 | 4.7 | 4.7 | 9.4 | 28.2 | 174 | 739 | 4707 |
| Tully | 5792 | 7996 | 6768 | 3368 | 1605 | 630 | 441 | 409 | 346 | 472 | 1007 | 2644 | 31479 |
| Townsville | 2807 | 2885 | 1692 | 469 | 156 | 68.5 | 39.1 | 68.5 | 39.1 | 117 | 372 | 1076 | 9790 |
| Bowen | 1466 | 1310 | 708 | 193 | 101 | 87.3 | 46.0 | 41.4 | 41.4 | 50.5 | 110 | 446 | 4600 |
| Mt Isa | 326 | 285 | 188 | 41.4 | 35.3 | 23.1 | 9.7 | 3.7 | 8.5 | 32.9 | 56.0 | 210 | 1219 |
| Mackay | 2142 | 1875 | 1275 | 445 | 193 | 126 | 59.3 | 44.5 | 51.9 | 133 | 237 | 830 | 7411 |
| Rockhampton | 769 | 806 | 497 | 144 | 166 | 92.0 | 66.2 | 69.9 | 58.9 | 169 | 276 | 570 | 3684 |
| Emerald | 379 | 352 | 206 | 84.8 | 61.3 | 68.6 | 48.7 | 32.5 | 43.3 | 86.6 | 155 | 287 | 1804 |
| Bundaberg | 750 | 542 | 375 | 193 | 128 | 119 | 83.3 | 41.7 | 50.6 | 119 | 188 | 390 | 2979 |
| Gympie | 664 | 788 | 515 | 259 | 131 | 124 | 83.9 | 51.1 | 102 | 161 | 245 | 522 | 3646 |
| Roma | 296 | 260 | 231 | 90.0 | 74.7 | 64.5 | 66.2 | 40.8 | 57.7 | 124 | 163 | 229 | 1697 |
| Brisbane | 671 | 686 | 512 | 286 | 178 | 159 | 111 | 77.9 | 77.9 | 193 | 300 | 452 | 3705 |
| Toowoomba | 504 | 414 | 285 | 161 | 127 | 100 | 89.7 | 58.1 | 79.2 | 166 | 248 | 409 | 2642 |
| Southport | 597 | 699 | 621 | 383 | 289 | 203 | 125 | 85.9 | 85.9 | 187 | 242 | 391 | 3909 |
| New South Wales/ACT | | | | | | | | | | | | | |
| Lismore | 753 | 952 | 773 | 456 | 338 | 276 | 210 | 128 | 123 | 230 | 353 | 527 | 5119 |
| Taree | 423 | 454 | 463 | 311 | 224 | 187 | 140 | 103 | 137 | 171 | 205 | 295 | 3113 |
| Newcastle | 385 | 501 | 536 | 416 | 346 | 307 | 233 | 183 | 198 | 218 | 225 | 342 | 3890 |
| Bathurst | 202 | 175 | 139 | 92.9 | 73.8 | 65.6 | 57.4 | 61.5 | 71.1 | 119 | 135 | 172 | 1365 |
| Sydney | 405 | 491 | 487 | 413 | 342 | 301 | 212 | 190 | 152 | 212 | 264 | 253 | 3721 |
| Bega | 258 | 379 | 337 | 186 | 160 | 179 | 93.0 | 88.4 | 95.3 | 142 | 170 | 235 | 2323 |
| Albury | 125 | 139 | 145 | 123 | 113 | 126 | 99.3 | 99.3 | 96.4 | 156 | 125 | 136 | 1483 |
| Canberra | 204 | 179 | 159 | 118 | 91.6 | 56.1 | 56.1 | 62.0 | 90.1 | 143 | 164 | 154 | 1477 |
| Victoria | | | | | | | | | | | | | |
| Mildura | 45.5 | 44.3 | 35.3 | 21.3 | 30.8 | 34.1 | 18.9 | 27.1 | 30.4 | 43.1 | 35.3 | 43.5 | 410 |
| Bendigo | 106 | 102 | 93.1 | 88.7 | 92.0 | 88.7 | 74.5 | 76.7 | 90.9 | 107 | 87.6 | 88.7 | 1097 |
| Sale | 130 | 141 | 139 | 91.7 | 64.3 | 66.7 | 46.5 | 57.2 | 79.8 | 116 | 111 | 148 | 1190 |
| Melbourne | 139 | 142 | 125 | 115 | 82.3 | 55.7 | 51.9 | 54.4 | 82.3 | 123 | 134 | 159 | 1265 |
| Geelong | 90.4 | 110 | 108 | 89.4 | 77.1 | 60.6 | 52.4 | 54.5 | 76.1 | 90.4 | 112 | 106 | 1027 |
| Ballarat | 101 | 124 | 95.4 | 94.2 | 88.5 | 67.8 | 65.5 | 80.4 | 96.5 | 110 | 103 | 122 | 1149 |
| Tasmania | | | | | | | | | | | | | |
| Launceston | 95.9 | 107 | 72.7 | 101 | 90.4 | 69.4 | 92.6 | 85.9 | 83.7 | 100 | 93.7 | 109 | 1102 |
| Hobart | 105 | 97.5 | 99.6 | 103 | 61.5 | 68.9 | 58.3 | 60.4 | 71.0 | 102 | 96.5 | 136 | 1059 |
| South Australia | | | | | | | | | | | | | |
| Port Augusta | 37.8 | 80.1 | 33.7 | 29.2 | 43.8 | 31.7 | 26.2 | 22.7 | 37.8 | 64.0 | 40.8 | 55.4 | 503 |
| Port Lincoln | 32.2 | 38.0 | 41.5 | 64.4 | 72.3 | 86.6 | 93.8 | 79.5 | 65.9 | 53.7 | 41.5 | 48 | 718 |
| Adelaide | 39.6 | 50.2 | 41.6 | 64.7 | 83.2 | 71.3 | 55.5 | 51.5 | 51.5 | 58.1 | 46.2 | 46.9 | 660 |
| Mt Gambier | 72.6 | 63.2 | 72.6 | 92.6 | 109 | 106 | 106 | 103 | 89.5 | 86.3 | 71.6 | 79.0 | 1053 |
| Western Australia | | | | | | | | | | | | | |
| Broome | 702 | 633 | 401 | 105 | 78.0 | 43.6 | 11.5 | 2.3 | 2.3 | 2.3 | 39.0 | 273 | 2293 |
| Geraldton | 69.6 | 167 | 247 | 191 | 630 | 762 | 592 | 407 | 185 | 111 | 69.6 | 52.2 | 3485 |
| Perth | 33.8 | 62.0 | 78.9 | 169 | 437 | 612 | 510 | 389 | 228 | 178 | 70.5 | 50.8 | 2820 |
| Albany | 66.5 | 51.9 | 85.9 | 139 | 209 | 201 | 214 | 182 | 169 | 141 | 94.1 | 66.5 | 1620 |
| Northern Territory | | | | | | | | | | | | | |
| Darwin | 1300 | 935 | 663 | 246 | 25.5 | 4.2 | 0.0 | 0.0 | 17.0 | 106 | 276 | 671 | 4245 |
| Katherine | 967 | 795 | 597 | 89.9 | 10.8 | 3.6 | 3.6 | 0.0 | 18.0 | 82.7 | 280 | 755 | 3603 |

Sourced from Yu (1998)

Table E2 – Monthly percentage and annual rainfall erosivity (R-factor) values

| Location | Jan | Feb | Mar | Apr | May | Jun | Jul | Aug | Sep | Oct | Nov | Dec | Yearly R-value |
|----------------------------|--|------|------|------|------|------|------|------|------|------|------|------|----------------|
| | Monthly percentage erosivity values | | | | | | | | | | | | |
| Queensland | | | | | | | | | | | | | |
| Weipa | 26.9 | 27.9 | 18.8 | 4.5 | 0.4 | 0.1 | 0.0 | 0.0 | 0.2 | 1.1 | 5.1 | 15.1 | 4786 |
| Cairns | 24.7 | 27.1 | 23.6 | 6.9 | 2.1 | 0.7 | 0.3 | 0.4 | 0.6 | 1.0 | 3.8 | 8.7 | 19118 |
| Normanton | 32.7 | 27.8 | 16.1 | 2.2 | 0.3 | 0.5 | 0.1 | 0.1 | 0.2 | 0.6 | 3.7 | 15.7 | 4707 |
| Tully | 18.4 | 25.4 | 21.5 | 10.7 | 5.1 | 2.0 | 1.4 | 1.3 | 1.1 | 1.5 | 3.2 | 8.4 | 31479 |
| Townsville | 28.7 | 29.5 | 17.3 | 4.8 | 1.6 | 0.7 | 0.4 | 0.7 | 0.4 | 1.2 | 3.8 | 11.0 | 9790 |
| Bowen | 31.9 | 28.5 | 15.4 | 4.2 | 2.2 | 1.9 | 1.0 | 0.9 | 0.9 | 1.1 | 2.4 | 9.7 | 4600 |
| Mt Isa | 26.8 | 23.4 | 15.4 | 3.4 | 2.9 | 1.9 | 0.8 | 0.3 | 0.7 | 2.7 | 4.6 | 17.2 | 1219 |
| Mackay | 28.9 | 25.3 | 17.2 | 6.0 | 2.6 | 1.7 | 0.8 | 0.6 | 0.7 | 1.8 | 3.2 | 11.2 | 7411 |
| Rockhampton | 20.9 | 21.9 | 13.5 | 3.9 | 4.5 | 2.5 | 1.8 | 1.9 | 1.6 | 4.6 | 7.5 | 15.5 | 3684 |
| Emerald | 21.0 | 19.5 | 11.4 | 4.7 | 3.4 | 3.8 | 2.7 | 1.8 | 2.4 | 4.8 | 8.6 | 15.9 | 1804 |
| Bundaberg | 25.2 | 18.2 | 12.6 | 6.5 | 4.3 | 4.0 | 2.8 | 1.4 | 1.7 | 4.0 | 6.3 | 13.1 | 2979 |
| Gympie | 18.2 | 21.6 | 14.1 | 7.1 | 3.6 | 3.4 | 2.3 | 1.4 | 2.8 | 4.4 | 6.7 | 14.3 | 3646 |
| Roma | 17.4 | 15.3 | 13.6 | 5.3 | 4.4 | 3.8 | 3.9 | 2.4 | 3.4 | 7.3 | 9.6 | 13.5 | 1697 |
| Brisbane | 18.1 | 18.5 | 13.8 | 7.7 | 4.8 | 4.3 | 3.0 | 2.1 | 2.1 | 5.2 | 8.1 | 12.2 | 3705 |
| Toowoomba | 19.1 | 15.7 | 10.8 | 6.1 | 4.8 | 3.8 | 3.4 | 2.2 | 3.0 | 6.3 | 9.4 | 15.5 | 2642 |
| Southport | 15.3 | 17.9 | 15.9 | 9.8 | 7.4 | 5.2 | 3.2 | 2.2 | 2.2 | 4.8 | 6.2 | 10.0 | 3909 |
| New South Wales/ACT | | | | | | | | | | | | | |
| Lismore | 14.7 | 18.6 | 15.1 | 8.9 | 6.6 | 5.4 | 4.1 | 2.5 | 2.4 | 4.5 | 6.9 | 10.3 | 5119 |
| Taree | 13.6 | 14.6 | 14.9 | 10.0 | 7.2 | 6.0 | 4.5 | 3.3 | 4.4 | 5.5 | 6.6 | 9.5 | 3113 |
| Newcastle | 9.9 | 12.9 | 13.8 | 10.7 | 8.9 | 7.9 | 6.0 | 4.7 | 5.1 | 5.6 | 5.8 | 8.8 | 3890 |
| Bathurst | 14.8 | 12.8 | 10.2 | 6.8 | 5.4 | 4.8 | 4.2 | 4.5 | 5.2 | 8.7 | 9.9 | 12.6 | 1365 |
| Sydney | 10.9 | 13.2 | 13.1 | 11.1 | 9.2 | 8.1 | 5.7 | 5.1 | 4.1 | 5.7 | 7.1 | 6.8 | 3721 |
| Bega | 11.1 | 16.3 | 14.5 | 8.0 | 6.9 | 7.7 | 4.0 | 3.8 | 4.1 | 6.1 | 7.3 | 10.1 | 2323 |
| Albury | 8.4 | 9.4 | 9.8 | 8.3 | 7.6 | 8.5 | 6.7 | 6.7 | 6.5 | 10.5 | 8.4 | 9.2 | 1483 |
| Canberra | 13.8 | 12.1 | 10.8 | 8.0 | 6.2 | 3.8 | 3.8 | 4.2 | 6.1 | 9.7 | 11.1 | 10.4 | 1477 |
| Victoria | | | | | | | | | | | | | |
| Mildura | 11.1 | 10.8 | 8.6 | 5.2 | 7.5 | 8.3 | 4.6 | 6.6 | 7.4 | 10.5 | 8.6 | 10.6 | 410 |
| Bendigo | 9.7 | 9.3 | 8.5 | 8.1 | 8.4 | 8.1 | 6.8 | 7.0 | 8.3 | 9.8 | 8.0 | 8.1 | 1097 |
| Sale | 10.9 | 11.8 | 11.7 | 7.7 | 5.4 | 5.6 | 3.9 | 4.8 | 6.7 | 9.7 | 9.3 | 12.4 | 1190 |
| Melbourne | 11.0 | 11.2 | 9.9 | 9.1 | 6.5 | 4.4 | 4.1 | 4.3 | 6.5 | 9.7 | 10.6 | 12.6 | 1265 |
| Geelong | 8.8 | 10.7 | 10.5 | 8.7 | 7.5 | 5.9 | 5.1 | 5.3 | 7.4 | 8.8 | 10.9 | 10.3 | 1027 |
| Ballarat | 8.8 | 10.8 | 8.3 | 8.2 | 7.7 | 5.9 | 5.7 | 7.0 | 8.4 | 9.6 | 9.0 | 10.6 | 1149 |
| Tasmania | | | | | | | | | | | | | |
| Launceston | 8.7 | 9.7 | 6.6 | 9.2 | 8.2 | 6.3 | 8.4 | 7.8 | 7.6 | 9.1 | 8.5 | 9.9 | 1102 |
| Hobart | 9.9 | 9.2 | 9.4 | 9.7 | 5.8 | 6.5 | 5.5 | 5.7 | 6.7 | 9.6 | 9.1 | 12.8 | 1059 |
| South Australia | | | | | | | | | | | | | |
| Port Augusta | 7.5 | 15.9 | 6.7 | 5.8 | 8.7 | 6.3 | 5.2 | 4.5 | 7.5 | 12.7 | 8.1 | 11.0 | 503 |
| Port Lincoln | 4.5 | 5.3 | 5.8 | 9.0 | 10.1 | 12.1 | 13.1 | 11.1 | 9.2 | 7.5 | 5.8 | 6.7 | 718 |
| Adelaide | 6.0 | 7.6 | 6.3 | 9.8 | 12.6 | 10.8 | 8.4 | 7.8 | 7.8 | 8.8 | 7.0 | 7.1 | 660 |
| Mt Gambier | 6.9 | 6.0 | 6.9 | 8.8 | 10.4 | 10.1 | 10.1 | 9.8 | 8.5 | 8.2 | 6.8 | 7.5 | 1053 |
| Western Australia | | | | | | | | | | | | | |
| Broome | 30.6 | 27.6 | 17.5 | 4.6 | 3.4 | 1.9 | 0.5 | 0.1 | 0.1 | 0.1 | 1.7 | 11.9 | 2293 |
| Geraldton | 2.0 | 4.8 | 7.1 | 5.5 | 18.1 | 21.9 | 17.0 | 11.7 | 5.3 | 3.2 | 2.0 | 1.5 | 3485 |
| Perth | 1.2 | 2.2 | 2.8 | 6.0 | 15.5 | 21.7 | 18.1 | 13.8 | 8.1 | 6.3 | 2.5 | 1.8 | 2820 |
| Albany | 4.1 | 3.2 | 5.3 | 8.6 | 12.9 | 12.4 | 13.2 | 11.2 | 10.4 | 8.7 | 5.8 | 4.1 | 1620 |
| Northern Territory | | | | | | | | | | | | | |
| Darwin | 30.6 | 22.0 | 15.6 | 5.8 | 0.6 | 0.1 | 0.0 | 0.0 | 0.4 | 2.5 | 6.5 | 15.8 | 4245 |
| Katherine | 26.8 | 22.1 | 16.6 | 2.5 | 0.3 | 0.1 | 0.1 | 0.0 | 0.5 | 2.3 | 7.8 | 21.0 | 3603 |

Sourced from Yu (1998)

E3.3 LS-factor

The LS-factor is a numerical representation of the length–slope combination. The LS-factor may be obtained from Table E3, (Landcom, 2004).

Table E3 – Slope–length, LS-factors for RUSLE

| Slope gradient (%) | Slope length (m) | | | | | | | | | | | | |
|--------------------|------------------|------|------|------|------|------|------|------|------|------|------|------|------|
| | 5 | 10 | 20 | 30 | 40 | 50 | 60 | 70 | 80 | 90 | 100 | 150 | 200 |
| 1 | 0.09 | 0.11 | 0.13 | 0.15 | 0.16 | 0.17 | 0.18 | 0.19 | 0.19 | 0.20 | 0.20 | 0.23 | 0.24 |
| 2 | 0.14 | 0.18 | 0.24 | 0.28 | 0.31 | 0.34 | 0.36 | 0.39 | 0.41 | 0.43 | 0.44 | 0.52 | 0.58 |
| 3 | 0.17 | 0.24 | 0.34 | 0.41 | 0.47 | 0.52 | 0.57 | 0.61 | 0.65 | 0.69 | 0.72 | 0.87 | 1.00 |
| 4 | 0.21 | 0.30 | 0.44 | 0.54 | 0.63 | 0.71 | 0.78 | 0.85 | 0.91 | 0.97 | 1.03 | 1.26 | 1.47 |
| 5 | 0.24 | 0.36 | 0.54 | 0.68 | 0.80 | 0.91 | 1.01 | 1.10 | 1.19 | 1.27 | 1.35 | 1.70 | 2.00 |
| 6 | 0.28 | 0.42 | 0.64 | 0.81 | 0.97 | 1.11 | 1.24 | 1.36 | 1.47 | 1.58 | 1.68 | 2.14 | 2.54 |
| 8 | 0.34 | 0.53 | 0.83 | 1.08 | 1.31 | 1.51 | 1.70 | 1.88 | 2.05 | 2.21 | 2.37 | 3.07 | 3.70 |
| 10 | 0.42 | 0.68 | 1.09 | 1.44 | 1.75 | 2.04 | 2.31 | 2.56 | 2.81 | 3.04 | 3.27 | 4.06 | 4.94 |
| 12 | 0.52 | 0.85 | 1.39 | 1.85 | 2.27 | 2.66 | 3.02 | 3.37 | 3.70 | 4.02 | 4.33 | 5.77 | 7.07 |
| 14 | 0.62 | 1.02 | 1.69 | 2.26 | 2.79 | 3.28 | 3.74 | 4.18 | 4.61 | 5.02 | 5.42 | 7.27 | 8.95 |
| 16 | 0.71 | 1.19 | 1.98 | 2.67 | 3.31 | 3.90 | 4.46 | 5.00 | 5.52 | 6.02 | 6.51 | 8.78 | |
| 18 | 0.80 | 1.35 | 2.27 | 3.07 | 3.82 | 4.51 | 5.17 | 5.81 | 6.42 | 7.02 | 7.59 | | |
| 20 | 0.89 | 1.50 | 2.55 | 3.47 | 4.32 | 5.12 | 5.88 | 6.61 | 7.32 | 8.01 | 8.68 | | |
| 25 | 1.09 | 1.88 | 3.23 | 4.43 | 5.54 | 6.59 | 7.60 | 8.57 | 9.51 | | | | |
| 30 | 1.28 | 2.23 | 3.86 | 5.32 | 6.69 | 7.99 | 9.23 | | | | | | |
| 40 | 1.61 | 2.83 | 4.98 | 6.92 | 8.74 | | | | | | | | |
| 50 | 1.88 | 3.33 | 5.89 | 8.22 | | | | | | | | | |

The *slope* and *length* are defined along a drainage line of “sheet” flow from its point of origin to either a location where:

- the gradient is so flat that sediment deposition will occur (this is usually not the case within a construction site); or
- the sheet flow enters the backwaters of a sediment trap/basin; or
- the sheet flow enters a drain, channel or valley floor containing concentrated flow.

Thus the LS-factor is representative of the sheet flow down the sides of a drainage sub-catchment, not the flow down the valley invert. A sub-catchment map prepared for the determination of a soil loss estimate is usually different from the sub-catchment map prepared for the development of Construction Drainage Plans (CDPs).

E3.4 K-factor

The K-factor is a numeric representation of the ability of soils to resist the erosive energy of rain. K-factors should be determined from laboratory analysis of soil data wherever practical, especially if an accurate estimation of soil loss is required.

A detailed explanation of the concept of erodibility as used in the RUSLE is given by Loch & Rosewell (1992) and Loch et al. (1998). Laboratory assessment of soil K-factors are essential if an accurate estimate of soil loss is needed. In the absence of site-specific data, an estimation of the likely K-factor for subsoils may be determined from Tables E4 or E5 depending on the available soil description. In the case where Tables E4 and E5 provide significantly different values, the higher value must be used.

To adjust for dispersive soils, K-factors should be increased by 20% for all Emersion Aggregate Class 1 and 2 soils (Landcom, 2004).

It should be noted that the soil erodibility parameters developed from the agricultural industry ordinarily relate to surface soils (topsoils). In civil construction it is usually the erosion potential of the subsoil that is of greater interest. Therefore, careful consideration must be given to the selection of soil erodibility parameters. Application of soil erodibility K-factor algorithms to subsoils are likely to give very approximate values only because soil erodibility research has predominantly been focussed on topsoils.

Table E4 – Default soil erodibility K-factors based on soil texture class

| Soil texture | Symbol | Estimated clay content (%) | K-factor ^[1] |
|----------------------|--------|---------------------------------|-------------------------|
| Sand | S | < 10 | 0.015 |
| Clayey sand | CLS | 5–10 | 0.025 |
| Loamy sand | LS | 5–10 | 0.020 |
| Sandy loam | SL | 10–15 | 0.030 |
| Fine sandy loam | FSL | 10–20 | 0.035 |
| Sandy clay loam | SCL | 15–20 | 0.025 |
| Loam | L | about 25 | 0.040 |
| Loam, fine sandy | Lfsy | about 25 | 0.050 |
| Silt loam | SiL | about 25 and more than 25% silt | 0.055 |
| Sandy clay loam | SCL | 20-30 | [0.043] |
| Clay loam | CL | 30–35 | 0.030 |
| Silty clay loam | SiCL | 30–35 and more than 25% silt | 0.040 |
| Fine sandy clay loam | FSCL | 30–35 | 0.025 |
| Sandy clay | SC | 35–40 | 0.017 |
| Silty clay | SiC | 35–40 and more than 25% silt | 0.025 |
| Light clay | LC | 35–40 | 0.025 |
| Light medium clay | LMC | 40–45 | 0.018 |
| Medium clay | MC | 45–55 | 0.015 |
| Heavy clay | HC | > 50 | 0.012 |

Note: [1] Rosewell (1993)

Table E5 – Typical K-factors based on Unified Soil Classification System

| Brief description | Code | Typical values | Default ^[1] |
|---|------|----------------|------------------------|
| Silty gravels, poorly graded gravel-sand-silt | GM | 0.00 – 0.06 | 0.053 |
| Clayey gravels, poorly graded gravel-sand-clay | GC | 0.00 – 0.05 | 0.042 |
| Well graded sands, gravelly sands, little fines | SW | 0.00 – 0.04 | 0.036 |
| Poorly graded sands, gravelly sands, few fines | SP | 0.00 – 0.03 | 0.027 |
| Silty sands, poorly graded sand-silt mixtures | SM | 0.01 – 0.05 | 0.043 |
| Clayey sands, poorly graded sand-clay mixtures | SC | 0.02 – 0.05 | 0.044 |
| Inorganic silts, clayey sands with slight plasticity | ML | 0.03 – 0.07 | 0.062 |
| Inorganic clays of low to medium plasticity | CL | 0.02 – 0.06 | 0.058 |
| Organic silts and organic silt-clay of low plasticity | OL | 0.01 – 0.04 | 0.033 |
| Inorganic silts, fine sands or silty soils, elastic silts | MH | 0.02 – 0.07 | 0.066 |
| Inorganic clays of high plasticity, elastic soils | CH | 0.00 – 0.05 | 0.047 |

Note: [1] Default values should be adopted in absence of local site data. The default values have been developed from a statistical analysis of NSW soil data (Landcom, 2004) and represent the statistical average plus one standard deviation for each soil type.

E3.5 C-factor

The C-factor measures the combined effect of all the interrelated cover and management variables. It also represents non-structural methods for controlling erosion. C-factors may be obtained from Tables E6 to E10.

Table E6 – C-factors for slopes less than 33%^[1]

| Product | Rate | Slope length on gradients < 33% | | |
|--------------------------------|----------------|---------------------------------|-----------|--------|
| | | < 6 m | 6 to 15 m | > 15 m |
| Hydromulch | 1.5 t/ha | 0.00 | 0.03 | 0.07 |
| Bonded Fibre Matrix (BFM) | 5 (fibre) t/ha | 0.00 | 0.03 | 0.07 |
| Jute mesh | – | 0.10 | 0.20 | 0.40 |
| Coconut fibre mesh | – | 0.10 | 0.20 | 0.40 |
| Curled wood fibre | – | 0.01 | 0.05 | 0.10 |
| Jute or coconut fibre blankets | – | 0.00 | 0.03 | 0.07 |
| Plastic fibres with netting | – | 0.00 | 0.05 | 0.10 |
| Composite synthetic blankets | – | 0.00 | 0.03 | 0.07 |
| Polymers/polyacrylamide | – | 0.01 | 0.05 | 0.10 |
| Bitumen emulsion | 12,000 L/ha | 0.01 | 0.05 | 0.10 |

Note: [1] Landcom (2004)

Table E7 – C-factors for slopes between 33 and 50%^[1]

| Product | Rate | Slope length on gradients 33-50% | | |
|--------------------------------|----------------|----------------------------------|-----------|---------|
| | | < 6 m | 6 to 15 m | > 15 m |
| Hydromulch | 1.5 t/ha | 0.03 | 0.06 | 0.10 |
| Bonded Fibre Matrix (BFM) | 5 (fibre) t/ha | 0.03 | 0.06 | 0.10 |
| Jute mesh | – | 0.20 | 0.40 | 0.60 |
| Coconut fibre mesh | – | 0.20 | 0.40 | 0.60 |
| Curled wood fibre | – | 0.10 | 0.15 | 0.20 |
| Jute or coconut fibre blankets | – | 0.03 | 0.06 | 0.10 |
| Plastic fibres with netting | – | 0.03 | 0.05 | 0.10 |
| Composite synthetic blankets | – | 0.03 | 0.06 | 0.10 |
| Polymers/polyacrylamide | – | 0.10 | No Data | No Data |
| Bitumen emulsion | 12,000 L/ha | 0.10 | No Data | No Data |

Note: [1] Landcom (2004)

Table E8 – C-factors for newly established grass cover^[1]

| Seeding | Mulch | t/ha | C-factor | |
|---|----------|------|------------------|----------------|
| | | | during emergence | post emergence |
| Temporary (grain or fast growing grass) | Straw | 2.5 | 0.20 | 0.07 |
| | Straw | 3.8 | 0.12 | 0.05 |
| | Stone | 330 | 0.05 | 0.05 |
| | Stone | 600 | 0.02 | 0.02 |
| | Woodchip | 17 | 0.08 | 0.05 |
| | Woodchip | 30 | 0.05 | 0.02 |
| | Woodchip | 62 | 0.02 | 0.02 |
| Permanent seeding second year | | | | 0.01 |
| Turf | | | 0.01 | 0.01 |

Note: [1] Garvin et al. (1979).

Table E9 – C-factors for newly established grass cover^[1]

| Type and height of raised canopy | Canopy cover | Type of cover | Ground cover (%) | | | | | |
|----------------------------------|--------------|---------------|------------------|------|------|------|------|------|
| | | | 0 | 20 | 40 | 60 | 80 | 95 |
| No appreciable cover | 0 | Grass | 1.00 | 0.45 | 0.22 | 0.10 | 0.03 | 0.00 |

Note: [1] Landcom (2004)

Table E10 – C-factors for long established vegetative cover^[1]

| Type and height of raised canopy ^[2] | Canopy cover ^[3] | Type of cover ^[4] | Ground cover (%) | | | | | |
|--|-----------------------------|------------------------------|------------------|------|------|------|------|------|
| | | | 0 | 20 | 40 | 60 | 80 | 95 |
| No appreciable cover | 0 | G | 0.45 | 0.20 | 0.10 | 0.04 | 0.01 | 0.00 |
| | | W | 0.45 | 0.24 | 0.15 | 0.09 | 0.04 | 0.01 |
| Canopy of tall weeds or short brush (0.5 m raindrop fall height) | 25 | G | 0.36 | 0.17 | 0.09 | 0.04 | 0.01 | 0.00 |
| | | E | 0.36 | 0.20 | 0.13 | 0.08 | 0.04 | 0.01 |
| | 50 | G | 0.26 | 0.13 | 0.07 | 0.04 | 0.01 | 0.00 |
| | | E | 0.26 | 0.16 | 0.11 | 0.08 | 0.04 | 0.01 |
| | 75 | G | 0.17 | 0.10 | 0.06 | 0.03 | 0.01 | 0.00 |
| | | W | 0.17 | 0.10 | 0.06 | 0.03 | 0.01 | 0.00 |
| Appreciable brush (2 m raindrop fall height) | 25 | G | 0.40 | 0.18 | 0.09 | 0.04 | 0.01 | 0.00 |
| | | W | 0.40 | 0.22 | 0.14 | 0.09 | 0.04 | 0.01 |
| | 50 | G | 0.34 | 0.16 | 0.09 | 0.04 | 0.01 | 0.00 |
| | | W | 0.34 | 0.19 | 0.13 | 0.08 | 0.04 | 0.01 |
| | 75 | G | 0.28 | 0.14 | 0.08 | 0.04 | 0.01 | 0.00 |
| | | W | 0.28 | 0.17 | 0.12 | 0.01 | 0.04 | 0.01 |
| Trees, but not appreciable low brush (4 m raindrop fall height) | 25 | G | 0.42 | 0.19 | 0.10 | 0.04 | 0.01 | 0.00 |
| | | W | 0.42 | 0.23 | 0.14 | 0.09 | 0.04 | 0.01 |
| | 50 | G | 0.39 | 0.18 | 0.09 | 0.04 | 0.01 | 0.00 |
| | | W | 0.39 | 0.21 | 0.14 | 0.09 | 0.04 | 0.01 |
| | 75 | G | 0.36 | 0.17 | 0.09 | 0.04 | 0.01 | 0.00 |
| | | W | 0.36 | 0.20 | 0.13 | 0.08 | 0.04 | 0.01 |

Notes for Table E10:

- [1] Values assume that random distribution of mulch or vegetation, mulch of appreciable depth, and land has not been cultivated for a period of 3 years. Sourced from Garvin et al. (1979).
- [2] Average fall height of water drops from vegetation canopy to soil surface.
- [3] Portion of the total surface area that would be hidden from view by vegetative canopy (excludes ground cover).
- [4] G = cover at surface is grass, grass-like plants, decaying vegetable matter or litter at least 50 mm deep.
 W = cover at surface is mostly broadleaf herbaceous plants (as weeds) with little lateral-root network near the surface and/or undecayed residue.

E3.6 P-factor

The P-factor measures the combined effect of all support practices and management variables. It also represents structural methods for controlling erosion.

The P-factor is reduced by practices that reduce both the velocity of runoff and the tendency of runoff to flow directly downhill. At construction sites, it reflects the roughening or smoothing of the soil surface by machinery. The P-factor may be obtained from Table E11 (Landcom, 2004).

Table E11 – Erosion control practice, P-factors

| Surface condition | P-factor |
|---|----------|
| Compacted and smooth (default construction phase condition) | 1.3 |
| Trackwalked along the contour | 1.2 |
| Trackwalked up and down the slope | 0.9 |
| Straw punched into loose ground by disc harrow | 0.9 |
| Loose to 300 mm depth | 0.8 |

Note: [1] Straw mulch has been punched into a loose ground surface with a disc harrow.

E4 References

Garvin, R.J., Knight, M.Z. and Richmond, T.J. 1979, *Guidelines for Minimising Soil Erosion and Sedimentation from Construction Sites in Victoria*. Soil Conservation Authority, Victoria.

Landcom 2004, *Managing Urban Stormwater: Soils and Construction – Volume-1*, Landcom, New South Wales Government, ISBN 0-9752030-3-7.

Lane, L.J. and Nearing, M.A. 1989, *USDA Water Erosion Prediction Project: Hillslope Profile Model Documentation*, USDA National Soil Erosion Research Laboratory Report No.2, West Lafayette, Indiana, USA.

Loch, R.J. and Rosewell, C.J. (1992). Laboratory methods for measurement of soil erodibilities (K factors) for the Universal Soil Loss Equation. *Australian Journal of Soil Research* 30: 233-248.

Loch, R.J., Slater, B.K., and Devoil, C. (1998). Soil erodibility (K) values for some Australian soils. *Australian Journal of Soil Research* 36: 1045-1056.

Renard, K.G., Foster, G.R., Weesies, G.A. and McCool, D.K. 1997, *Predicting Soil Erosion by Water: A Guide to Conservation Planning with the Revised Universal Soil Loss Equation (RUSLE)*, USDA Agricultural Handbook No. 703, US Government Printer Office, Washington DC.

Renard, K.G., Foster, G.R., Weesies, G.A. and Porter, J.P. 1991, *RUSLE: Revised universal soil loss equation*, *Journal of Soil and Water Conservation* 46, USA.

Rosewell, C.J. 1993, *SOILOSS A Program to assist in the selection of management practices to reduce erosion*. Technical Handbook No. 11, NSW Soil Conservation Service, ISBN 0 7305 5931 9.

Rosewell, C.J. and Loch, R.J. 2002, *Estimation of the RUSLE Soil Erodibility Factor*, in N.J. McKenzie, K.J. Coughlan and H.P. Cresswell (eds), "Soil Physical Measurements and Interpretation for Land Evaluation", CSIRO Publishing, Melbourne.

Rosewell, C.J. and Turner, J.B. 1992, *Rainfall erosivity in New South Wales*. CaLM Technical Report No. 20, NSW Department of Conservation and Land Management, Sydney.

Williams, J.R. and Berndt, H.D. 1977, *Sediment yield prediction based on watershed hydrology*, *Transactions of the American Society of Agricultural Engineers* 27, USA.

Wischmeier, W.H. and Smith, D.D. 1978, *Predicting Rainfall Erosion Losses: A Guide to Conservation Planning*, USDA Agriculture Handbook No. 537, Washington DC.

Yu, B. 1998, *Rainfall erosivity and its estimation for Australia's tropics*, *Australian Journal of Soil Research*, Vol. 36, No. 1, 143-165.

Appendix F

Erosion hazard assessment

This appendix provides example procedures for conducting an Erosion Hazard Assessment on a proposed land development. Its function within this document is both educational and prescriptive.

F1. Introduction

Erosion Hazard Assessment is a procedure for undertaking a “preliminary” assessment of the environmental hazard associated with the construction of a given land development. The assessment is based on the land development as a whole, and does not look at individual drainage catchments within the development. Erosion hazard within individual sub-catchments of a development can be assessed using soil loss prediction tools such as RUSLE, for more information refer to Appendix E – *Soil loss estimation*.

An erosion hazard assessment may be performed for a number of reasons, including:

- to identify those land developments that require a preliminary assessment of ESC issues during the planning phase;
- to identify those developments that require a review of the Erosion and Sediment Control Plan (ESCP) by an ESC specialist, such as a Certified Professional in Erosion and Sediment Control (CPESC), an accreditation system administered by the International Erosion Control Association (IECA).

As an example, proponents of developments assessed as high-risk may be required to:

- submit a draft ESCP during the development planning phase;
- submit to the regulatory authority the results of specific soil testing;
- have their final ESCP reviewed by an ESC specialist.

Two methods for assessing the Erosion Hazard are provided within this appendix. Regulatory authorities may choose either system, or an alternative system that better satisfies their needs.

An alternative erosion hazard assessment form for small building sites is provided in Appendix H – *Building sites*.

Technical Note F1 – Erosion Hazard Assessment vs erosion risk rating

Erosion Hazard Assessment is different from the erosion risk rating systems introduced in Section 4.4 (Chapter 4 – *Design standards and technique selection*) of this document for the determination of the Erosion Control Standard. The adoption of an erosion risk rating system allows regulatory authorities to relate the Erosion Control Standard to either the estimated soil loss rate (i.e. RUSLE analysis), the monthly erosivity (i.e. monthly R-factor), or the average monthly rainfall depth.

The Erosion Control Standard can be linked to just the rainfall erosivity or monthly rainfall depth—without consideration of other factors such as surface area, land slope and soil type—because the focus is primarily on raindrop impact erosion rather than sheet and rill erosion. It is noted that the Sediment Control Standard is best linked to the estimated soil loss rate which considers both sheet and rill erosion rates.

F2 TASK number erosion hazard assessment system

The following Erosion Hazard Assessment system is based on a modification of the Revised Universal Soil Loss Equation (RUSLE). The TASK number is directly proportional to the estimated total soil loss within a given region (i.e. for a given rainfall erosivity).

$$H = T . A . S . K \quad (F1)$$

where:

H = Numerical value of the TASK number

T = Duration of soil disturbance [months]

A = Total area of soil disturbance [m²]

S = Slope factor (Table F2 or Equation F3)

K = Soil erosivity factor (RUSLE K-factor)

The TASK number is used to identify low-risk and high-risk short-term land disturbances within a given region. Regulatory authorities may assign their own trigger value for high-risk sites, however, if a local trigger value has not been adopted, then a default value of 200 is recommended as per Table F1.

Table F1 – Default high-risk trigger value

| Hazard Rating | Low-risk | High-risk |
|--------------------|----------|----------------|
| TASK Number | < 200 | 200 or greater |

If at the planning stage it is possible to subdivide the soil disturbance area into sub-areas of near-uniform land slope, then the TASK number represents the sum of TASK values determined for each sub-area with soil erodibility K-factor values determined for each sub-area as per Equation F2.

$$\text{TASK Number} = \sum (T.A.S.K) \quad (F2)$$

T-factor:

The duration of disturbance refers to the total amount of time that the site will be exposed to potential rainfall for the duration of the construction project, or a given stage of the project (if known) up until a time when there is at least 70% vegetative cover, or 100% synthetic cover of all areas of disturbed soil.

In regions where seasonal rainfall is well defined, then the duration of exposure should not include those periods when rainfall is not considered likely to occur.

A-factor:

Note: the A-factor used in the TASK number is **not** the same as the “A” term determined from a RUSLE analysis.

The total area of soil disturbance refers to the maximum area of the disturbance that will occur at any given time over the duration of the project. If at the planning stage it is not possible to determine the staging of works, then the area of disturbance must be taken as the total area of disturbance for all stages of the project.

Well-vegetated (protected) land not disturbed by the development project should not be included in the analysis.

S-factor:

The slope factor (S) is based on that land slope of which no more than 10% of the land is steeper. Values of the S-factor are provided in Table F2 and Equation F3. These values are based on the RUSLE's LS-factor for a slope length limited to the best management practice values presented in Table 4.3.2 of Chapter 4 – *Design standards and technique selection*.

Table F2 – Slope factor

| Slope (%) | 1% | 2% | 3% | 4% | 5% | 6% | 8% | 10% | 15% | 20% | 30% |
|-----------------|------|------|------|------|------|------|------|------|------|------|------|
| S-factor | 0.21 | 0.35 | 0.48 | 0.61 | 0.73 | 0.85 | 1.08 | 1.29 | 1.75 | 2.12 | 2.58 |

$$\text{S-factor} = 0.071 + 0.141 (\text{Slope } \%) - 0.0019 (\text{Slope } \%)^2 \quad (\text{F3})$$

K-factor:

The soil erodibility K-factor is the same as the term used in the RUSLE analysis. Preliminary soil testing (refer to Chapter 3 – *Site planning*) will be required to determine the soil classification group.

Table F3 – Nominal K-factors based on Unified Soil Classification System

| Brief description | Code | Typical values | Default ^[1] |
|---|------|----------------|------------------------|
| Silty gravels, poorly graded gravel-sand-silt | GM | 0.00 – 0.06 | 0.053 |
| Clayey gravels, poorly graded gravel-sand-clay | GC | 0.00 – 0.05 | 0.042 |
| Well graded sands, gravelly sands, little fines | SW | 0.00 – 0.04 | 0.036 |
| Poorly graded sands, gravelly sands, few fines | SP | 0.00 – 0.03 | 0.027 |
| Silty sands, poorly graded sand-silt mixtures | SM | 0.01 – 0.05 | 0.043 |
| Clayey sands, poorly graded sand-clay mixtures | SC | 0.02 – 0.05 | 0.044 |
| Inorganic silts, clayey sands with slight plasticity | ML | 0.03 – 0.07 | 0.062 |
| Inorganic clays of low to medium plasticity | CL | 0.02 – 0.06 | 0.058 |
| Organic silts and organic silt-clay of low plasticity | OL | 0.01 – 0.04 | 0.033 |
| Inorganic silts, fine sands or silty soils, elastic silts | MH | 0.02 – 0.07 | 0.066 |
| Inorganic clays of high plasticity, elastic soils | CH | 0.00 – 0.05 | 0.047 |

Notes: [1] Default values should be adopted in absence of local site data. The default values have been developed from a statistical analysis of NSW soil data (Landcom, 2004) and represent the statistical average plus one standard deviation for each soil type.

F3. Point score erosion hazard assessment system

The following erosion hazard assessment form is presented as an example. Regulatory authorities may choose to modify its contents and/or trigger value to better address local issues and conditions (e.g. within the catchment of sensitive receiving waters).

The **total score** is used to identify certain actions required by the proponent, or may simply be used to identify *low-risk* and *high-risk* sites. Within the attached form, a total score of 17 (default value) or greater may be considered *high-risk*.

The **trigger values** are used to identify issues of particular importance and to trigger specific actions required by the proponent, such as the submission of a preliminary ESCP during the planning phase of the development.

Table F4 – Erosion hazard assessment form

| Condition | Points | Score | Trigger value |
|---|-----------------------|-------|---------------|
| AVERAGE SLOPE OF DISTURBANCE AREA [1] <ul style="list-style-type: none"> not more than 3% [3% . 33H:1V] more than 3% but not more than 5% [5% = 20H:1V] more than 5% but not more than 10% [10% = 10H:1V] more than 10% but not more than 15% [15% . 6.7H:1V] more than 15% | 0 1 2 4 6 | | 4 |
| SOIL CLASSIFICATION GROUP (AS1726) [2] <ul style="list-style-type: none"> GW, GP, GM, GC SW, SP, OL, OH SM, SC, MH, CH ML, CL, or if <i>imported fill</i> is used, or if soils are untested | 0 1 2 3 | | |
| EMERSON (DISPERSION) CLASS NUMBER [3] <ul style="list-style-type: none"> Class 4, 6, 7, or 8 Class 5 Class 3, (default value if soils are untested) Class 1 or 2 | 0 2 4 6 | | 6 |
| DURATION OF SOIL DISTURBANCE [4] <ul style="list-style-type: none"> not more than 1 month more than 1 month but not more than 4 months more than 4 months but not more than 6 months more than 6 months | 0 2 4 6 | | 6 |
| AREA OF DISTURBANCE [5] <ul style="list-style-type: none"> not more than 1000 m² more than 1000 m² but not more than 5000 m² more than 5000 m² but not more than 1 ha more than 1 ha but not more than 4 ha more than 4 ha | 0 1 2 4 6 | | 4 |
| WATERWAY DISTURBANCE [6] <ul style="list-style-type: none"> No disturbance to a watercourse, open drain or channel Involves disturbance to a constructed open drain or channel Involves disturbance to a natural watercourse | 0 1 2 | | 2 |
| REHABILITATION METHOD [7] Percentage of area (relative to total disturbance) revegetated by seeding without light mulching (i.e. worst-case revegetation method). <ul style="list-style-type: none"> not more than 1% more than 1% but not more than 5% more than 5% but not more than 10% more than 10% | 0 1 2 4 | | |
| RECEIVING WATERS [8] <ul style="list-style-type: none"> Saline waters only Freshwater body (e.g. creek or freshwater lake or river) | 0 2 | | |
| SUBSOIL EXPOSURE [9] <ul style="list-style-type: none"> No subsoil exposure except of service trenches Subsoils are likely to be exposed | 0 2 | | |
| EXTERNAL CATCHMENTS [10] <ul style="list-style-type: none"> No external catchment External catchment diverted around the soil disturbance External catchment not diverted around the soil disturbance | 0 1 2 | | |
| ROAD CONSTRUCTION [11] <ul style="list-style-type: none"> No road construction Involves road construction works | 0 2 | | |
| pH OF SOILS TO BE REVEGETATED [12] <ul style="list-style-type: none"> more than pH 5.5 but less than pH 8 other pH values, or if soils are untested | 0 1 | | |
| Total Score ^[13] | | | |

Explanatory notes (Point Score system)

Requirements: Specific issues or actions required by the proponent.

Warnings: Issues that should be considered by the proponent.

Comments: General information relating to the topic.

[1] **REQUIREMENTS:**

For sites with an average slope of proposed land disturbance greater than 10%, a preliminary ESCP must be submitted to the regulatory authority for approval during planning negotiations.

Proponents must demonstrate that adequate erosion and sediment control measures can be implemented on-site to effectively protect downstream environmental values.

If site or financial constraints suggest that it is not reasonable or practicable for the prescribed water quality objectives to be achieved for the proposal, then the proponent must demonstrate that alternative designs or construction techniques (e.g. pole homes, suspended slab) cannot reasonably be implemented on the site.

WARNINGS:

Steep sites usually require more stringent drainage and erosion controls than flatter grade sites.

COMMENTS:

The steeper the land, the greater the need for adequate drainage controls to prevent soil and mulch from being washed from the site.

[2] **REQUIREMENTS:**

If the actual soil K-factor is known from soil testing, then the Score shall be determined from Table F5.

If a preliminary ESCP is required during planning negotiations, then it must be demonstrated that adequate space is available for the construction and operation of any major sediment traps, including the provision for any sediment basins and their associated embankments and spillways. It must also be demonstrated that all reasonable and practicable measures can be taken to divert the maximum quantity of sediment-laden runoff (up to the specified design storm) to these sediment traps throughout the construction phase and until the contributing catchment is adequately stabilised against erosion.

WARNINGS:

The higher the point score, the greater the need to protect the soil from raindrop impact and thus the greater the need for effective erosion control measures. A point score of 2 or greater will require a greater emphasis to be placed on revegetation techniques that do not expose the soil to direct rainfall contact during vegetation establishment, e.g. turfing and *Hydromulching*.

COMMENTS:

Table F6 provides an *indication* of soil conditions likely to be associated with a particular Soil group based on a statistical analysis of soil testing across NSW. This table provides only an initial estimate of the likely soil conditions.

The left-hand-side of the table provides an indication of the type of sediment basin that will be required (Type C, F or D). The right-hand-side of the table provides an indication of the likely erodibility of the soil based on the Revised Universal Soil Loss Equation (RUSLE) K-factor.

Table F7 provides some general comments on the erosion potential of the various soil groups.

Table F5 – Score if soil K-factor is known

| | RUSLE soil erodibility K-factor | | | |
|--------------|---------------------------------|-------------|-------------|----------|
| | K < 0.02 | 0.02<K<0.04 | 0.04<K<0.06 | K > 0.06 |
| Score | 0 | 1 | 2 | 3 |

Table F6 – Statistical analysis of NSW soil data ^[1]

| Unified Soil Class System | Likely sediment basin classification (%) | | | Probable soil erodibility K-factor (%) ^[2] | | | |
|---------------------------|--|-----------|-----------|---|-------------|-------------|-----------|
| | Dry | Wet | | Low | Moderate | High | Very High |
| | Type C | Type F | Type D | K < 0.02 | 0.02<K<0.04 | 0.04<K<0.06 | K > 0.06 |
| GM | 30 | 58 | 12 | 12 | 51 | 26 | 12 |
| GC | 42 | 33 | 25 | 13 | 71 | 17 | 0 |
| SW | 40 | 48 | 12 | 49 | 39 | 12 | 0 |
| SP | 53 | 32 | 15 | 76 | 18 | 5 | 1 |
| SM | 21 | 67 | 12 | 26 | 48 | 25 | 1 |
| SC | 26 | 50 | 24 | 16 | 64 | 18 | 2 |
| ML | 5 | 63 | 32 | 4 | 35 | 45 | 16 |
| CL | 9 | 51 | 39 | 12 | 56 | 19 | 13 |
| OL | 2 | 80 | 18 | 34 | 61 | 5 | 1 |
| MH | 12 | 41 | 48 | 15 | 19 | 41 | 25 |
| CH | 5 | 44 | 51 | 39 | 43 | 11 | 7 |

Notes: [1] Analysis of soil data presented in Landcom (2004).

[2] Soil erodibility based on Revised Universal Soil Loss Equation (RUSLE) K-factor.

Unified Soil Classification System (USCS)

- GW Well graded gravels, gravel-sand mixtures, little or no fines
- GP Poorly graded gravels, gravel-sand mixture, little or no fines
- GM Silty gravels, poorly graded gravel-sand-silt mixtures
- GC Clayey gravels, poorly graded gravel-sand-clay mixtures
- SW Well graded sands, gravelly sands, little or no fines
- SP Poorly graded sands, gravelly sands, little or no fines
- SM Silty sands, poorly graded sand-silt mixtures
- SC Clayey sands, poorly graded sand-clay mixtures
- ML Inorganic silts & very fine sands, rock flour, silty or clayey fine sands with slight plasticity
- CL Inorganic clays, low–medium plasticity, gravelly clays, sandy clays, silty clays, lean clays
- OL Organic silts and organic silt-clays of low plasticity
- MH Inorganic silts, micaceous or diatomaceous fine sandy or silty soils, elastic silts
- CH Inorganic clays of high plasticity, fat clays
- OH Organic clays of medium to high plasticity

Table F7 – Typical properties of various soil groups ^[1]

| Soil Groups | Typical properties ^[2] |
|-------------|--|
| GW, GP | <ul style="list-style-type: none"> • Low erodibility potential. |
| GM, GC | <ul style="list-style-type: none"> • Low to medium erodibility potential. • May create turbid runoff if disturbed as a result of the release of silt and clay particles. |
| SW, SP | <ul style="list-style-type: none"> • Low to medium erodibility potential. |
| SM, SC | <ul style="list-style-type: none"> • Medium erodibility potential. • May create turbid runoff if disturbed as a result of the release of silt and clay particles. |
| MH, CH | <ul style="list-style-type: none"> • Highly variable (low to high) erodibility potential. • Will generally create turbid runoff if disturbed. |
| ML, CL | <ul style="list-style-type: none"> • High erodibility potential. • Tendency to be dispersive. • May create some turbidity in runoff if disturbed. |

Note: [1] After Soil Services & NSW DLWC (1998).

[2] Any soil can represent a high erosion risk if the binding clays or silts are unstable.

Table F8 provides **general** guidelines on the suitability of various soil groups to various engineering applications.

Table F8 – Engineering suitability based on Unified Soil Classification ^[1]

| Unified Soil Class | USC Group | Embankments | | Fill | Slope stability | Untreated roads |
|----------------------|-----------|-------------------------|---------------------|------------|-----------------|-----------------|
| | | Water retaining | Non water retaining | | | |
| Well graded gravels | GW | Unsuitable | Excellent | Excellent | Excellent | Average |
| Poorly graded gravel | GP | Unsuitable | Average | Excellent | Average | Unsuitable |
| Silty gravels | GM | Unsuitable | Average | Good | Average | Average |
| Clayey gravels | GC | Suitable | Average | Good | Average | Excellent |
| Well graded sands | SW | Unsuitable | Excellent | Excellent | Excellent | Average |
| Poorly graded sands | SP | Unsuitable | Average | Good | Average | Unsuitable |
| Silty sands | SM | Suitable ^[2] | Average | Average | Average | Poor |
| Clayey sands | SC | Suitable | Average | Average | Average | Good |
| Inorganic silts | ML | Unsuitable | Poor | Average | Poor | Unsuitable |
| Inorganic clays | CL | Suitable ^[2] | Good | Average | Good | Poor |
| Organic silts | OL | Unsuitable | Unsuitable | Poor | Unsuitable | Unsuitable |
| Inorganic silts | MH | Unsuitable | Poor | Poor | Poor | Unsuitable |
| Inorganic clays | CH | Suitable ^[2] | Average | Unsuitable | Average | Unsuitable |
| Organic clays | OH | Unsuitable | Unsuitable | Unsuitable | Unsuitable | Unsuitable |
| Highly organic soils | Pt | Unsuitable | Unsuitable | Unsuitable | Unsuitable | Unsuitable |

Notes: [1] Modified from Hazelton & Murphy (1992)

[2] Suitable only after modifications to soil such as compaction and/or erosion protection

- [3] If the soils have not been tested for Emerson Class, then adopt a score of 4.

REQUIREMENTS:

Works proposed on sites containing Emerson Class 1 or 2 soils have a very high pollution potential and must submit a conceptual ESCP to the regulatory authority for review and/or approval (as required by the authority) during planning negotiations.

WARNINGS:

Class 3 and 5 soils disturbed by cut and fill operations or construction traffic are highly likely to discolour stormwater (i.e. cause turbid runoff). Chemical stabilisation will likely be required if these soils are placed immediately adjacent to a retaining wall. Any disturbed Class 1, 2, 3 and 5 soils that are to be revegetated must be covered with a non-dispersive topsoil as soon as possible (unless otherwise agreed by the regulatory authority).

Class 1 and 2 soils are highly likely to discolour (pollute) stormwater if exposed to rainfall or flowing water. Treatment of these soils with gypsum (or other suitable substance) will most likely be required. These soils should not be placed directly behind a retaining wall unless it has been adequately treated (stabilised) or covered with a non-dispersible soil.

- [4] The duration of disturbance refers to the total duration of soil exposure to rainfall up until a time when there is at least 70% coverage of all areas of soil.

REQUIREMENTS:

All land developments with an expected soil disturbance period greater than 6 months must submit a conceptual ESCP to the regulatory authority for review and/or approval (as required by the authority) during planning negotiations.

COMMENTS:

Construction periods greater than 3 months will generally experience at least some significant storm events, independent of the time of year that the construction (soil disturbance) occurs.

- [5] **REQUIREMENTS:**

Development proposals with an expected soil disturbance in excess of 1ha must submit a conceptual ESCP to the regulatory authority for review and/or approval (as required by the regulatory authority) during planning negotiations.

The area of disturbance refers to the total area of soil exposed to rainfall or dust-producing winds either as a result of:

- (a) the removal of ground cover vegetation, mulch or sealed surfaces;
- (b) past land management practices;
- (c) natural conditions.

WARNINGS:

A *Sediment Basin* will usually be required if the disturbed area exceeds 0.25ha (2500m²) within any sub-catchment (i.e. land flowing to one outlet point).

COMMENTS:

For soil disturbances greater than 0.25ha, the revegetation phase should be staged to minimise the duration for which soils are exposed to wind, rain and concentrated runoff.

[6] REQUIREMENTS:

All developments that involve earthworks or construction within a natural watercourse (whether that watercourse is in a natural or modified condition) must submit a conceptual ESCP to the regulatory authority for review and/or approval (as required by the regulatory authority) during planning negotiations.

Permits and/or licences may be required from the State Government, including possible submission of the ESCP to the relevant Government department.

COMMENTS:

The management of works within a natural watercourse is discussed in Appendix I – *Instream works*.

[7] REQUIREMENTS:

No areas of soil disturbance shall be left exposed to rainfall or dust-producing winds at the end of a development without an adequate degree of protection and/or an appropriate action plan for the establishment of at least 70% cover.

COMMENTS:

Grass seeding without the application of a light mulch cover is considered the least favourable revegetation technique. A light mulch cover is required to protect the soil from raindrop impact, excessive temperature fluctuations, and the loss of essential soil moisture.

[8] COMMENTS:

All receiving waters can be adversely affected by unnatural quantities of sediment-laden runoff. Freshwater ecosystems are generally more susceptible to ecological harm resulting from the inflow of fine or dispersible clays than saline water bodies. The further inland a land disturbance is, the greater the potential for the released sediment to cause environmental harm as this sediment travels towards the coast.

For the purpose of this clause it is assumed that all sediment-laden runoff will eventually flow into saline waters. Thus, sediment-laden discharges that flow first into freshwater are likely to adversely affect both fresh and saline water bodies and are therefore considered potentially more damaging to the environment.

This clause does **not** imply that sediment-laden runoff will not cause harm to saline waters.

[9] COMMENTS:

This clause refers to subsoils exposed during the construction phase either as a result of past land practices or proposed construction activities. The exposure of subsoils resulting from the excavation of minor service trenches should not be considered.

[10] WARNINGS:

The greater the extent of external catchment, the greater the need to divert up-slope stormwater runoff around any soil disturbance.

COMMENTS:

The ability to separate “clean” (i.e. external catchment) stormwater runoff from “dirty” site runoff can have a significant effect on the size, efficiency and cost of the temporary drainage, erosion, and sediment control measures.

[11] REQUIREMENTS:

Permission must be obtained from the owner of a road reserve before placing any erosion and sediment control measures within the road reserve.

WARNINGS:

Few sediment control techniques work efficiently when placed on a road and/or around roadside stormwater inlets. Great care must be taken if sediment control measures are located on a public roadway, specifically:

- safety issues relating to road users;
- the risk of causing flooding on the road or within private property.

The construction of roads (whether temporary or permanent) will usually modify the flow path of stormwater runoff. This can affect how “dirty” site runoff is directed to the sediment control measures.

COMMENTS:

“On-road” sediment control devices are at best viewed as secondary or supplementary sediment control measures. Only in special cases and/or on very small projects (e.g. kerb and channel replacement) might these controls be considered as the “primary” sediment control measure.

[12] WARNINGS:

Soils with a pH less than 5.5 or greater than 8 will usually require treatment in order to achieve satisfactory revegetation. Soils with a pH of less than 5 (whether naturally acidic or in acid sulfate soil areas) may also limit the choice of chemical flocculants (e.g. Alum) for use in the flocculation of *Sediment Basins*.

[13] REQUIREMENTS:

A preliminary ESCP must be submitted to the local government for approval during the planning phase for any development that obtains a total point score of 17 or greater or when any trigger value is scored or exceeded.

Appendix G

Model code of practice

This appendix presents a model Code of Practice for erosion and sediment control on construction sites, as well as acting as a default Code of Practice. Government bodies are encouraged to either adopt the default code, or develop their own regional-based Code of Practice using this model code as a template.

Persons wishing to apply this Code of Practice should first ensure that they familiar with the principles of erosion and sediment control outlined in Chapter 2 – Principles of erosion and sediment control.

A model Code of Practice for the building industry is provided in Appendix H – Building sites.

A model Code of Practice for instream works is provided in Appendix I – Instream works.

A model Code of Practice for the installation of minor services is provided in Appendix L – Installation of services.

G1. Introduction

The construction industry is increasingly moving towards the adoption of development codes and standards as opposed to the use of guidelines and manuals. Unfortunately not all aspects of the construction industry can be successfully codified. History, however, has shown that a well-worded construction contract, ESC Standard, or Code of Practice can often do more to control soil erosion and sediment runoff on construction sites than the best ESC Guideline.

The development of a Code of Practice for construction site erosion and sediment control is still in its early stages of refinement and it is likely that it will require a number of modifications before a successful code is finally developed.

G2. Use of this model Code of Practice

There are a number of ways a regulatory authority may choose to incorporate Erosion and Sediment Control (ESC) conditions into a development or other land disturbing activity. For example, an authority may choose to:

- (i) adopt one or more of the model Codes of Practice presented in this document (model codes are also presented in Appendix H, I and L);
- (ii) develop their own ESC Code of Practice;
- (iii) develop their own ESC Standard/Code based on those development approval conditions (refer to Section G3) that are likely to be common to all development sites in their area;
- (iv) control on-site erosion and sediment control issues through the specification of site specific development approval conditions.

G3. Example development approval conditions

The following development approval conditions have been provided as a guide only. Project managers and regulatory authorities should review the following example conditions to determine which conditions will be applicable to a particular region or development application. The conditions are based on development approval by a local government—state and federal agencies must make appropriate modifications to the wording of each clause.

It is recognised that it is neither reasonable nor practicable for all of the following development conditions to be applied on all sites. Discretion needs to be applied by regulators in the selection and application of these conditions.

If contradiction exists between any of the conditions, then those conditions that best achieve the aims or intent of the Erosion and Sediment Control Plan (ESCP) shall apply.

The following development conditions have been developed from those presented in Brisbane City Council (2000), Landcom (2004) and Sitewise (undated).

G3.1 Development planning and design

1. All reasonable and practicable measures must be taken to minimise changes to the volume, frequency, duration, and velocity of stormwater runoff such that changes to the natural water cycle and the risk of causing, or contributing to, accelerated erosion within downstream waterways are minimised.
2. Where increased stormwater runoff from a proposed development (including land subdivision) is likely to accelerate erosion of any watercourse, appropriate measures must be taken to prevent or minimise this erosion.
3. Erosion and sediment control (ESC) measures must be an integral component of the project's planning, design, and costing.
4. The location and design of the proposed works must take appropriate consideration of the need to minimise potential erosion problems during the construction and operational phases of the project (e.g. through minimisation of watercourse crossings and the avoidance of high erosion hazard areas).
5. To the maximum degree reasonable and practicable, the development layout must aim to minimise the duration that any and all areas of soil will be required to be exposed to the erosive effects of wind, rain, and surface runoff during the construction period.
6. The staging and/or layout of the works must not cause unnecessary soil disturbance if an acceptable alternative staging/layout is available that achieves the same or equivalent project outcomes at no unreasonable additional cost.
7. Adequate site data, including soil data, must be obtained prior to, or during, the planning phase to identify potential site constraints (e.g. dispersive or acid sulfate soils) and to appropriately recognise/integrate these constraints into site planning.
8. A Conceptual Erosion and Sediment Control Plan shall be submitted to Council if, in accordance with Council's Erosion Hazard Assessment procedures, the site is classified as high-risk, or represents a high or extreme erosion hazard.
9. The development must adopt best practice erosion and sediment control techniques and practices.

G3.2 Construction planning

10. To the maximum degree reasonable and practicable, the construction site layout and construction program must aim to minimise the duration that any and all areas of soil will be exposed to the erosive effects of wind, rain and surface runoff during the construction period.
11. The construction site layout, methodology, staging and programming must not cause unnecessary environmental harm if an alternative layout, methodology, staging or program (which reduces unnecessary soil disturbance and/or potential environmental harm) is available that achieves the same or equivalent project outcomes at a reasonable cost.
12. The construction site layout and construction program must take appropriate consideration of the need to minimise potential erosion problems during the construction and operational phases of the project (e.g. through minimisation of temporary watercourse crossings and the avoidance of high erosion hazard areas and construction practices).
13. Soil disturbances must be staged into manageably sized areas of no greater than 3.5ha to ensure adequate ESC management and progressive stabilisation of disturbed surfaces.
14. To the maximum degree reasonable and practicable, all necessary soil sampling and analysis must be completed prior to commencement of bulk earthworks.
15. An Erosion and Sediment Control Plan must be prepared by suitably trained and experienced personnel and submitted to *[insert organisation]* prior to commencement of construction.
16. An Erosion and Sediment Control Plan must be prepared by suitably trained and experienced personnel and approved by *[insert organisation]* prior to commencement of construction. (*alternative to above*)
17. An Erosion and Sediment Control Plan must be prepared by suitably trained and experienced personnel and approved by *[insert organisation]* prior to access to the site being granted for commencement of construction. (*alternative to above*)
18. On sites with a soil disturbance greater than 2500m², a Site Stabilisation Plan, Landscape Plan, and/or Vegetation Management Plan must be prepared and approved by Council prior to initial land clearing or bulk earthworks. Such a plan(s) must show progressive stabilisation of exposed soil for erosion control purposes including, but not limited to all of the following:
 - (i) schedule for stabilisation of exposed soil areas; and
 - (ii) specifications for subsoil and topsoil preparation and application; and
 - (iii) specification of stabilisation by mulching or other appropriate surface treatment (note that grass seeding without adequate mulching is not permitted); and
 - (iv) details on the type and application rate of any tackifiers to be used in the application of any specified mulches (including hydromulch, Bonded Fibre Matrix, and Compost Blankets).
19. On sites with a soil disturbance greater than 2500m², a Monitoring and Maintenance Program is prepared by, or under the supervision of, suitably qualified and experienced personnel.
20. On sites with a soil disturbance greater than 2500m², an event-based Water Quality Monitoring Program must be prepared and approved by Council prior to initial land clearing or bulk earthworks. Such a Program must document proposed water quality monitoring, and include:
 - (i) location of instream water quality monitoring stations; and
 - (ii) water quality monitoring, sampling and analysis procedures and standards.

21. A performance bond in the form of a bank guarantee must be submitted to Council prior to commencement of construction in accordance with *[insert clause or policy]* to ensure effective erosion mitigation, sediment control, and site rehabilitation measures are implemented.

G3.3 Erosion and Sediment Control Plans (ESCPs)

22. Adequate site data, including soil data, must be obtained to allow the preparation of an appropriate Erosion and Sediment Control Plan, and allow the selection, design and specification of required ESC measures.
23. Prior to development of the Erosion and Sediment Control Plan, the site must be assessed from a hydrological, hydraulic, vegetation, soils and geological perspective to determine relevant site constraints that may affect the focus or detail of the Plan.
24. A Conceptual Erosion and Sediment Control Plan must include plan(s) (no larger than 1:1000), and must address the following issues:
 - (i) identify the likely need for Sediment Basins on the site; and
 - (ii) identify that adequate space has been made available for the construction and operation of major sediment traps and essential flow diversion systems; and
 - (iii) demonstrate that there is a feasible means of constructing the project while still protecting key environmental values; and
 - (iv) identify problematic soil areas including, dispersive soils, acid sulfate soils, areas of potential mass movement; and
 - (v) identify key environmental features/values on the site such as protected vegetation.
25. Preparation of an Erosion and Sediment Control Plan as part of the development application/approval process is required for the following types of land-disturbing activities:
 - (i) development that increases site impermeability by more than 15%, involves site excavation or filling exceeding 100m³ or site disturbance greater than 250m²; or
 - (ii) re-configuration of an allotment involving land disturbance, multi-unit dwellings, commercial and industrial developments; or
 - (iii) or any land-disturbing development subject to Code Assessment (e.g. multi-unit dwellings, commercial and industrial developments, filling and excavation); where such activities are deemed to be high or extreme risk in accordance with Council's Erosion Hazard Assessment procedures, or
 - (iv) any other land-disturbing development that is deemed to be high or extreme risk by Council or other creditable source.
26. If an Erosion and Sediment Control Plan is required by Council, then this plan must be prepared at the expense of the Applicant or owner, and approved by Council prior to the commencement of any work or activity, including land clearing, except for the purposes of ground survey, geotechnical investigation, or other recognised essential purposes, provided the work:
 - (i) is consistent with the State's and Council's Vegetation Protection and/or Preservation requirements and/or policies; and
 - (ii) is conducted in accordance with current best management practice; and
 - (iii) is undertaken so that the earth/soil surface is not disturbed and at least 150mm stubble remains on the surface (where such a stubble exists prior to clearing); or
 - (iv) is to provide essential site access via the minimum practicable number of site access corridors.

27. The level of detail supplied in the Erosion and Sediment Control Plan must be commensurate with the complexity of the proposal and the assessed environmental risk.
28. The Erosion and Sediment Control Plan must include plan(s) (no larger than 1:1000), supporting documentation, and construction specifications that can be readily understood and applied on-site. The plan(s) must include all aspects of proposed site disturbance, temporary drainage works, erosion and sediment control measures, installation sequence, and site rehabilitation for the duration of the project, including (where appropriate) the nominated maintenance period.
29. On sites with a soil disturbance greater than 2500m², the Erosion and Sediment Control Plan (including supporting documentation) must include:
 - (i) North point and plan scale.
 - (ii) Site and easement boundaries and adjoining roadways.
 - (iii) Construction access points.
 - (iv) Site office, car park and location of material stockpiles.
 - (v) Limits of disturbance.
 - (vi) Retained vegetation including protected trees.
 - (vii) General soil information and location of problematic soils.
 - (viii) Location of critical environmental values (where appropriate).
 - (ix) Existing site contours (unless the provision of these contours adversely impacts the clarity of the ESCP).
 - (x) Final site contours including locations of cut and fill.
 - (xi) Construction Drainage Plans for each stage of earthworks, including land contours for that stage of construction, sub-catchment boundaries and location of watercourses.
 - (xii) General layout and staging of proposed works.
 - (xiii) Location of all drainage, erosion and sediment control measures.
 - (xiv) Full design and construction details (e.g. cross-sections, minimum channel grades, channel linings,) for all drainage and sediment control devices, including *Diversion Channels* and *Sediment Basins*.
 - (xv) Site revegetation requirements (if not contained on a separate plan submitted to Council).
 - (xvi) Site Monitoring and Maintenance Program, including the location of proposed water quality monitoring stations.
 - (xvii) Technical notes relating to:
 - site preparation and land clearing;
 - extent, timing and application of erosion control measures;
 - temporary ESC measures installed at end of working day;
 - temporary ESC measures in case of impending storms, or emergency situations;
 - installation sequence for ESC measures;
 - site revegetation and rehabilitation requirements;
 - application rates (or at least the minimum application rates) for mulching and revegetation measures;
 - legend of standard symbols used within the plans.
 - (xviii) Calculation sheets for the sizing of ESC measures.
 - (xix) A completed Erosion and Sediment Control Plan checklist such as presented in *[insert publication]*.
 - (xx) Any other relevant information Council may require to properly assess the ESCP.

30. If the timing of the proposed construction activities are not known during development of the Erosion and Sediment Control Plan (ESCP), and if rainfall erosivity varies significantly throughout the year, then the erosion control specifications placed on the ESCP must specify appropriate erosion control measures for each level of rainfall erosivity.
31. On sites with a soil disturbance greater than one (1) hectare, the Erosion and Sediment Control Plan (ESCP) must include:
 - (i) individual ESCPs for: the bulk earthworks phase, roadworks and drainage phase and the practical completion/on-maintenance phases of construction. Each phase above must be documented graphically on a dedicated ESCP, or detail shown on an ESCP, and supported by a clearly documented construction sequence, or ESC installation sequence, which describes the timing of key ESC actions on the site; and
 - (ii) procedures for the temporary shutdown of the site (suitable for planned and unplanned shutdowns).
32. The Erosion and Sediment Control Plan must clearly state that no land-disturbing activities on the site shall occur until all perimeter ESC measures, sediment basins, and associated temporary drainage controls, have been constructed in accordance with current best practice erosion and sediment control.
33. On sites with a soil disturbance greater than 2500m², Erosion and Sediment Control Plans must be signed-off by a suitably qualified and experienced professional. A suitably qualified and experienced professional is defined as a person with:
 - (i) training and/or qualifications in erosion and sediment control that are recognised by the Council; and
 - (ii) professional affiliations with an engineering, environmental, soil science, and/or scientific organisation (e.g. the International Erosion Control Association; Engineers Australia; Environment Institute of Australia and New Zealand; and the Australian Society of Soil Science Inc.); and
 - (iii) at least two (2) years experience in the management of erosion and sediment control which can be verified by an independent third party.
34. When signing-off on an Erosion and Sediment Control Plan (ESCP), the signatory is deemed to be making the following statements:
 - (i) the ESCP satisfies the intent and design/performance standards established by all relevant local, State and Federal policies relating to erosion and sediment control; and
 - (ii) the ESCP has been reviewed and approved by personnel suitably trained and experienced (to a degree appropriate for the given type and size of the land disturbance) in each of the following categories: construction, soil science, hydrology/hydraulics, and site revegetation/rehabilitation; and
 - (iii) the ESCP is both reasonable and practicable; and
 - (iv) the ESCP contains sufficient information to allow the appropriate application of the plans.
35. Erosion and Sediment Control Plans (ESCPs) prepared for developments in excess of one (1) hectare, or where the ESCP incorporates a sediment basin, must be signed-off by an engineer experienced in hydrology and hydraulics.
36. Erosion and Sediment Control Plans that incorporate a sediment basin with a constructed earth embankment with a height greater than one (1) metre, must be signed-off by a geotechnical specialist.
37. The approved Erosion and Sediment Control Plan must be available on-site for inspection by Council officers while work activities are occurring.

38. Should the development be commenced and not completed within twelve (12) months of approval of the Erosion and Sediment Control Plan (ESCP), a revised ESCP must be prepared, with further revisions thereafter at half-yearly intervals.
39. Addition erosion and sediment control measures must be implemented, and a revised Erosion and Sediment Control Plan (ESCP) is to be submitted for approval (within five (5) business days of any such amendments) in the event that:
 - (i) there is a high probability that serious or material environmental harm may occur as a result of sediment leaving the site; or
 - (ii) the implemented works fail to achieve the local government ESC Standard/Code, or the State's environmental protection requirements; or
 - (iii) site conditions significantly change; or
 - (iv) site inspections indicate that the implemented works are failing to achieve the "objective" of the ESCP.
40. In circumstances where it is considered necessary to prepare an amended Erosion and Sediment Control Plan (ESCP), and the preparation of the amended ESCP is not imminent, then all necessary new or modified erosion and sediment control measures must be implemented in accordance with *[name of document]*. In circumstances where there is significant risk of environmental harm, then upon receipt of the amended ESCP, all works must be implemented in accordance with the revised plan. Otherwise, only upon approval of the amended ESCP by Council shall works be implemented in accordance with the amended plan.
41. A copy of any amended Erosion and Sediment Control Plan must be forwarded to Council *[insert officer]*, within five (5) business days of any such amendments.
42. The design standard of erosion and sediment control must be commensurate with the degree of environmental risk associated to the proposed works.
43. All ESC measures are to be designed to a standard commensurate with the site's environmental risk, and as a minimum, to a design standard approved by the Council. (*alternative to above*)
44. All erosion and sediment control measures, including temporary drainage control measures, must be designed in accordance with the design standards presented in *[insert publication]*.
45. The Erosion and Sediment Control Plan (ESCP) must incorporate "Hold Points" (where appropriate) detailing critical performance indicators of the various elements of the ESCP. The development must not be allowed to proceed without adherence to designated Hold Points at specified times.

G3.4 Site establishment

46. The Applicant must ensure that a copy of the Development Approval Conditions, Development Permit, Erosion and Sediment Control Plan, Monitoring and Maintenance Program, Landscape and/or Site Rehabilitation Plan, and any other documents required for the management of soil erosion and sediment control, are provided to the principal contractor prior to the commencement of land disturbing activities.
47. On sites with a soil disturbance greater than one (1) hectare, a Vegetation Management Plan is provided to the principal contractor prior to the commencement of land disturbing activities.
48. On sites with a soil disturbance greater than one (1) hectare, procedures for conducting a site shutdown (whether programmed or un-programmed), are provided to the principal contractor prior to the commencement of land disturbing activities.

49. Prior to the commencement of any construction activities, or soil disturbance (excluding that reasonably required for site investigation, survey or data collection), the Applicant must engage and nominate (in writing to Council) appropriately trained and experienced personnel to undertake regular ESC audits of the site, directly after a runoff-producing rainfall, and at no greater than fourteen (14) calendar day intervals, from the commencement of site disturbance until acceptance of the site by Council under “on-maintenance” conditions. Such personnel must, collectively, have the following capabilities:
- (i) an understanding of the local environmental values that could potentially be affected by the proposed works; and
 - (ii) a good working knowledge of the site’s Erosion and Sediment Control (ESC) issues, and potential environmental impacts that is commensurate with the complexity of the site and the degree of environmental risk; and
 - (iii) a good working knowledge of current best practice ESC measures appropriate for the given site conditions and type of works; and
 - (iv) ability to appropriately monitor, interpret, and report on the site’s ESC performance, including the ability to recognise poor performance and potential ESC problems; and
 - (v) ability to provide advice and guidance on appropriate measures and procedures to maintain the site at all times in a condition representative of current best practice, and that is reasonably likely to achieve the required ESC standard; and
 - (vi) a good working knowledge of the correct installation, operational and maintenance procedures for the full range of ESC measures used on the site.
50. Prior to commencement of site works the Applicant must document a specific list of personnel that details the “chain of command” in relation to the implementation, modification, and maintenance of site Erosion and Sediment Control measures. This document will, as a minimum, detail the ESC-related responsibilities and accountabilities of personnel, and must be updated to reflect any changes in staffing arrangements. This document will be provided to Council Officers at the Site Pre-start meeting. (*alternative to above*)
51. Prior to the commencement of any construction activity, or soil disturbance (excluding that reasonably required for site investigation, survey or data collection), the Applicant must engage and nominate at the pre-start meeting, a site representative (other than the principal contractor) to undertake regular ESC audits of the site, directly after a runoff-producing rainfall, and at no greater than fourteen (14) calendar day intervals, from the commencement of site disturbance until acceptance of the site by Council under “on-maintenance” conditions. (*alternative to above*)
52. Prior to the commencement of any construction activity, or soil disturbance (excluding that reasonably required for site investigation, survey, or data collection), the Applicant must nominate (in writing) a representative(s) to Council who has authority to ensure compliance with the development conditions with respect to erosion and sediment control. (*alternative to above*)
53. Prior to the commencement of construction, the Applicant is to provide a detailed program to Council showing the proposed timing for all works associated with the project, including the installation of erosion and sediment control measures.
54. A detailed landscape and rehabilitation plan for the site must be submitted to Council for approval prior to initial land clearing or bulk earthworks.
55. A permit must be provided by the Applicant to Council that entitles Council officers, and their representatives, to enter onto the land at any time to carry out additional erosion mitigation and sediment control works required as a result of

the development. The cost of any such works shall be fully recouped from the developer prior to any further works proceeding.

56. All office facilities and operational activities must be located such that any effluent, including wash-down water, can be totally contained and treated within the site.
57. Adequate waste collection bins must be provided on-site and maintained such that potential and actual environmental harm is minimised.

G3.5 Site access

58. Prior to the commencement of site works, the location of all site access point(s) must be verified with Council.
59. Site access must be stabilised and confined to the minimum practicable number of locations.
60. Vehicular access into the site must be appropriately managed to minimise the risk of sediment being tracked or washed onto adjoining sealed roadways.
61. All reasonable and practicable measures must be taken to ensure stormwater runoff from access roads and stabilised entry/exit systems, drains to an appropriate sediment control device.

G3.6 Site management

62. All land-disturbing activities must be conducted in accordance with the requirements of relevant legislation.
63. Any works that cause significant soil disturbance that is ancillary to any purpose for which external approval is required, must not commence before the issue of that approval.
64. The Applicant must ensure on-site soil erosion and the release of sediment and sediment-laden stormwater from the site is minimised at all times through compliance with an approved Erosion and Sediment Control Plan (as amended from time to time).
65. The Applicant must take all necessary actions to ensure that all land-disturbing activities are undertaken at all times in accordance with the current Erosion and Sediment Control Plan and the conditions of development approval. (*alternative to above*)
66. In circumstances where additional or alternative erosion and sediment control measures are required on a site, or a revised Erosion and Sediment Control Plan (ESCP) needs to be prepared, then only those works necessary to minimise or prevent environmental harm must be conducted on-site prior to preparation of a revised ESCP.
67. All ESC measures are to be constructed, operated and maintained in a manner that is commensurate with the site's environmental risk and/or erosion hazard assessment.
68. All erosion and sediment control measures must constructed, operated and maintained to the standards and specifications contained in either:
 - (i) the approved Erosion and Sediment Control Plan (as amended from time to time) and associated supporting documentation; or
 - (ii) the latest version of [*inert document*] if such standards and specifications are not contained in the approved Erosion and Sediment Control Plan.

69. All works subject to an approved Erosion and Sediment Control Plan (ESCP) must be carried out in accordance with the approved ESCP (as amended from time to time) unless circumstances arise where:
- (i) compliance with the ESCP would increase the potential for environmental harm as assessed by an authority recognised by Council—in which case the person(s) responsible may be required to take additional, or alternative protective measures; and/or
 - (ii) the Council or its representative determines that unacceptable off-site sedimentation is occurring as a result of a land-disturbing activity—in which case the person(s) responsible may be required to take additional, or alternative protective action, and/or undertake reasonable restoration works within the timeframe specified by the Council.
70. Land disturbing activities, other than *[insert items or relevant clause]* may only be undertaken without approval of an Erosion and Sediment Control Plan provided the land on which this work is undertaken:
- (i) is not within 40m of a river, stream, watercourse, lake, estuarine, lagoon, wetland or ridge line; and
 - (ii) has less than 10% of its area steeper than 4:1 (H:V); and
 - (iii) is not designated by Council, or other creditable source, as being geotechnically unstable; and
 - (iv) the height/depth of cut and/or fill does not exceed 1m; and
 - (v) the area of land affected is not greater than 250m²; and
 - (vi) uncontaminated up-site stormwater runoff is diverted around the earthworks (where appropriate and lawful); and
 - (vii) erosion and sediment control measures are adopted that minimise the release of sediment from the site; and
 - (viii) the site is appropriately rehabilitated/revegetated on completion.
71. The Applicant must ensure an adequate supply of erosion control, sediment control, and appropriate pollution clean-up materials are available on-site during the construction period.
72. Land-disturbing activities must be undertaken in such a manner that allows all reasonable and practicable measures to be undertaken to:
- (i) allow stormwater to pass through the site in a controlled manner and at non-erosive flow velocities; and
 - (ii) minimise soil erosion resulting from wind, rain, and flowing water; and
 - (iii) minimise the duration that disturbed soils are exposed to the erosive forces of wind, rain, and flowing water; and
 - (iv) minimise adverse effects of sediment runoff (including safety issues); and
 - (v) minimise or prevent environmental harm resulting from work-related soil erosion and sediment runoff; and
 - (vi) ensure that the value and use of land/properties adjacent to the development (including roads) are not diminished as a result of the adopted ESC measures.
73. Whenever the Council or its representative determines that unacceptable off-site sedimentation is occurring as a result of a land-disturbing activity, the person(s) responsible may be required to take additional, or alternative protective action, and/or undertake reasonable restoration works within the timeframe specified by the Council. (*alternative to above*)
74. Where circumstances change during construction and those circumstances could not have been foreseen, Council may require erosion and sediment control measures/works to be carried out in addition to, or instead of, those

measures/works specified in the approved plan and/or specifications. In such cases these works must be completed within the timeframe specified by the Council.

75. The construction schedule must aim to minimise the duration that any and all areas of soil are exposed to the erosive effects of wind, rain and flowing water.
76. Land disturbing activities must not cause unnecessary soil disturbance if an acceptable alternative construction process is available that achieves the same or equivalent outcomes at a reasonable cost.
77. Sediment, including clay, silt, sand, gravel, soil, mud, cement, and ceramic waste, deposited off the site as a direct result of on-site activities must be collected and the area cleaned/rehabilitated as soon as reasonable and practicable, with appropriate consideration given to both the safety and environmental risks associated with the sediment deposition.
78. Concrete waste and chemical products, including petroleum and oil-based products, must be prevented from entering any internal or external water body, or any external drainage system, excluding those on-site water bodies specifically designed to contain and/or treat such material.
79. All flammable and combustible liquids, including all liquid chemicals if such chemicals could potentially be washed or discharged from the site, must be stored and handled on-site in accordance with relevant standards such as AS1940 *“The storage and handling of flammable and combustible liquids”*.
80. Impervious bunds must be constructed around all storage areas containing more than one (1) cubic metre of petroleum and oil-based products such that the enclosed volume is large enough to contain 110% of the volume held in the largest, individual storage tank.
81. On-site personnel involved in the handling and storage of flammable and combustible liquids, including all liquid chemicals, must be appropriately trained and/or supervised, as required in order to allow such personnel to appropriately preform such activities.
82. Wherever reasonable and practicable, brick, tile or masonry cutting must be carried out on a pervious surface (e.g. grass or open soil), or in such a manner that any resulting sediment-laden runoff is prevented from discharging into a gutter, drain or water.
83. All reasonable and practicable measures must be taken to prevent the discharge of any cement-laden runoff (such as resulting from the formation of exposed aggregate surfaces) into stormwater drains or waterways.
84. Newly sealed hard-stand areas (e.g. roads, driveways and car parks) must be swept thoroughly as soon as practicable after sealing/surfacing to minimise the risk of components of the surfacing compound entering stormwater drains.
85. Trenches not located within roadways must be backfilled, capped with topsoil and compacted to a level at least 75mm above adjoining ground level and appropriately stabilised.
86. All stormwater, sewer line and other service trenches not located within roadways are to be mulched and seeded, or otherwise appropriately stabilised, within 7 days after backfill, or otherwise rehabilitated in accordance with the Vegetation Management Plan.
87. No more than 150m of stormwater, sewer line and services trenches not located within roadways shall be open at any one time.
88. Site spoil must be lawfully disposed of in a manner that does not result in ongoing soil erosion or environmental harm.

89. All fill material placed on site shall comprise only natural earth and rock, and is to be free of contaminants, be free draining, and be compacted in layers not exceeding 300mm to 90% modified maximum dry density in accordance with relevant standards such as AS1289.
90. The development must not be allowed to proceed without adherence to designated Hold Points contained within the Erosion and Sediment Control Plan.

G3.7 Site clearing

91. All site clearing must be conducted in accordance with the State's and Council's Vegetation Protection and/or Preservation requirements and/or policies.
92. No site clearing, land-disturbing activities, or earthworks shall be undertaken prior to approval of a Vegetation Management Plan.
93. Prior to the commencement of general site clearing, all areas of protected vegetation, and significant areas of retained vegetation, must be clearly identified as necessary to minimise the risk of disturbance to these areas.
94. No site clearing, other than provided for in *[insert clauses]*, land-disturbing activities, or earthworks, shall be undertaken prior to approval of engineering plans and/or an associated Erosion and Sediment Control Plan.
95. Land clearing must be delayed as long as reasonable and practicable and must be undertaken in conjunction with development of each stage of works, unless otherwise approved by *[insert name]*.
96. All reasonable and practicable efforts must be taken to delay the removal of, or disturbance to, existing ground cover (organic or inorganic) prior to land-disturbing activities.
97. Bulk tree clearing and grubbing of the site must be immediately followed by specified temporary erosion control measures (e.g. temporary grassing or mulching) prior to commencement of each stage of construction works.
98. Site clearing for the purposes of ground survey, geotechnical investigation, or other recognised essential purposes can be undertaken without development consent or approval, provided the work:
 - (i) is consistent with the State's and Council's Vegetation Protection and/or Preservation requirements and/or policies; and
 - (ii) is undertaken so that the ground surface is not disturbed and at least 150 mm stubble remains on the surface (where such a stubble exists prior to clearing); or
 - (iii) is to provide site access via the minimum practicable number of site access corridors.
99. Site clearing must be limited to 5m from the edge of proposed constructed works, 2m of essential construction traffic routes, and a total of 10m width for construction access, unless supported by an approved written proposal.
100. Land clearing must not extend beyond that necessary to provide up to eight (8) weeks of site activity during those months when the expected rainfall erosivity is less than 100, six (6) if between 100 and 285, four (4) weeks if between 285 and 1500, and two (2) weeks if greater than 1500.
101. Land clearing must not extend beyond that necessary to provide up to eight (8) weeks of site activity during those months when the actual or average rainfall is less than 45mm, six (6) if between 45 and 100mm, four (4) weeks if between 100 and 225mm, and two (2) weeks if greater than 225mm. (*alternative to above*)
102. Land clearing is limited to the minimum practicable during those periods when soil erosion due to wind, rain or surface water is possible. (*alternative to above*)

103. Site clearing must be staged into manageably-sized areas of no greater than 3.5ha to ensure adequate ESC management and progressive stabilisation of disturbed surfaces. (*alternative to above*)
104. Initial land-disturbing activities must be strictly limited to the establishment of the site compound, site entry/exit points, temporary drainage crossings and diversions (including stabilisation measures), haul road(s), perimeter sediment controls, and sediment basins (including emergency spillways). No catchment area shall be grubbed of vegetation or stripped of topsoil until the associated sediment basin/trap(s) are constructed and fully operational.
105. Trails and tracks for the purpose of bush fire prevention and control may be constructed without consent, provide they comply with State's and Council's relevant Bush Fire Control and Vegetation Protection Policies.
106. Disturbance to natural watercourses (including bed and banks) and their associated riparian zones must be limited to the minimum necessary to complete the approved works.
107. No land clearing shall be undertaken unless preceded or accompanied by installation of adequate drainage and sediment control measures unless such clearing is required for the purpose of installing such measures, in which case only the minimum clearing required to install such measures shall occur.
108. All reasonable measures must be undertaken to protect "retained" vegetation from damage to roots, trunk and branches.

G3.8 Soil and stockpile management

109. All reasonable and practicable measures must be taken to obtain the maximum benefit from existing topsoil, including:
 - (i) where the proposed area of soil disturbance does not exceed 2500m² and the topsoil does not contain undesirable weed seed, the top 100mm of topsoil (excluding material best described as subsoil) located within areas of proposed soil disturbance (including stockpile areas) must be stripped and stockpiled separately from the remaining soil; and
 - (ii) where the proposed area of soil disturbance exceeds 2500m² and the topsoil does not contain undesirable weed seed, the top 50mm of topsoil (excluding material best described as subsoil) must be stripped and stockpiled separately from the remaining soil, and spread as a final surface soil; and
 - (iii) in areas where the topsoil contains undesirable weed seed, the topsoil must be suitably buried, treated or removed from the site; or
 - (iv) topsoil is managed (i.e. stripped, stockpiled and reused) in accordance with the recommendations of an approved Vegetation Management Plan.
110. Stockpiles of erodible material must be:
 - (i) appropriately protected from wind, rain, concentrated surface flow, and excessive up-slope stormwater surface flows; and
 - (ii) located at least 2m from any hazardous area, retained vegetation, or concentrated drainage line; and
 - (iii) located up-slope of an appropriate sediment control system; and
 - (iv) provided with an appropriate protective cover (synthetic or organic) if the materials are likely to be stockpiled for more than four (4) weeks; or
 - (v) provided with an appropriate protective cover (synthetic or organic) if the materials are likely to be stockpiled for more than ten (10) days during months of high erosion risk (defined by clause *[insert clause]*); or

- (vi) provided with an appropriate protective cover (synthetic or organic) if the materials are likely to be stockpiled for more than five (5) days during months of extreme erosion risk (defined by clause *[insert clause]*).

G3.9 Drainage control

111. All temporary drainage control measures must be designed, installed, operated and maintained in accordance with the latest version of *[insert publication]*, or other approved publication.
112. All temporary drainage control measures must be designed to have a minimum non-erosive hydraulic capacity (excluding 150mm freeboard) in accordance with Table G1.

Table G1 – Drainage design standard for temporary drainage works

| Drainage structure | Anticipated design life | | |
|---|---|--------------|--------------|
| | < 12 months | 12–24 months | > 24 months |
| Temporary drainage structures ^[1] Queensland, Northern Territory, and northern Western Australia | 1 in 2 year | 1 in 5 year | 1 in 10 year |
| Temporary drainage structures ^[1] New South Wales, Victoria, Tasmania, South Australia and southern Western Australia | 1 in 5 year | 1 in 10 year | 1 in 10 year |
| Temporary drainage structures (e.g. Catch Drain, Flow Diversion Bank) located immediately up-slope of an occupied property that would be adversely affected by the failure or overtopping of the structure. ^{[1], [2]} | 1 in 10 year | 1 in 10 year | 1 in 10 year |
| Temporary culvert crossing | Minimum 1 in 1 year hydraulic capacity wherever reasonable and practicable. | | |

Notes: [1] Design capacity excludes minimum 150mm freeboard.

[2] Design flow rate based on up-slope drainage structures operating in accordance with their design capacity excluding freeboard, i.e. any constructed freeboard is assumed to have been washed away or otherwise deactivated.

113. Where the overtopping or failure of a temporary drainage system would likely cause detrimental flooding or nuisance to existing residential or commercial properties, the drainage system must have a minimum hydraulic capacity (excluding freeboard) equal to the 1 in 10 year ARI design storm.
114. Wherever reasonable and practicable, stormwater runoff entering the site from external areas, and non-sediment laden (clean) stormwater runoff entering a work area or area of soil disturbance, must be diverted around or through that area in a manner that minimises soil erosion and contamination of that water for all discharges up to the specified design storm discharge.
115. If the drainage area up-slope of a soil disturbance exceeds 1500m² and the average monthly rainfall exceeds 45mm, then all reasonable and practicable measures must be taken to divert this stormwater, up to the design storm, around or through the soil disturbance in a manner that minimises soil erosion and contamination of the water.
116. During construction, all reasonable and practicable measures must be implemented to control flow velocities in such a manner that prevents soil erosion

along drainage paths and at the entrance and exit of all drains and drainage structures during all storms up to the relevant design storm discharge.

117. To the maximum degree reasonable and practicable, all waters discharged during the construction phase must discharge onto stable land, in a non-erosive manner, and at a legal point of discharge.
118. Appropriate drainage controls must be installed above batters to prevent up-slope stormwater eroding the batter face.
119. Wherever reasonable and practicable, “clean” surface waters must be diverted away from sediment control devices.
120. During the construction period, roof water must be managed in a manner that minimises site wetness within active work areas, and soil erosion.
121. Stormwater from roofed areas must be connected to a Council approved stormwater disposal system immediately after placement of the roof.

G3.10 Erosion control

122. Wherever reasonable and practicable, priority must be given to the prevention, or at least the minimisation, of soil erosion, rather than the trapping of displaced sediment. Such a clause shall not reduce the responsibility to apply and maintain, at all times, all necessary sediment control measures.
123. Wherever reasonable and practicable, priority must be given to the prevention, or at least the minimisation, of soil erosion (i.e. drainage and erosion control measures), rather than allowing the erosion to occur and trying to trap the resulting sediment. Where this is not reasonable or practicable, then all reasonable and practicable measures must be taken to minimise soil erosion even if the adopted sediment control measures comply with the required treatment standard. (*alternative to above*)
124. Appropriate erosion control measures must be incorporated into all stages of a development, including each phase of earthworks.
125. All erosion control measures must be designed, installed, operated and maintained in accordance with the latest version of [*insert publication*], or other approved publication.
126. Within the limits of the current technology, erosion control measures used to control wind erosion must be commensurate with the expected seasonal wind conditions in terms of wind speed and direction.
127. The potential erosion risk shall be based on the rating outlined in Table G2. [*Table G2 presented as a default – Authorities may choose to select an alternative rating in reference to that outlined in Section 4.4 or Appendix F of this document*]

Table G2 – Erosion risk rating based on monthly rainfall erosivity

| Erosion risk rating | Average monthly erosivity (R-factor) |
|---------------------|--------------------------------------|
| Very Low | 0 to 60 |
| Low | 60+ to 100 |
| Moderate | 100+ to 285 |
| High | 285+ to 1500 |
| Extreme | >1500 |

128. All erosion control measures must be designed to satisfy, as a minimum, the design standard outlined in Table G3.

Table G3 – Best practice site clearing and rehabilitation requirements

| Risk | Best practice requirements |
|-----------|--|
| All cases | <ul style="list-style-type: none"> All reasonable and practicable steps taken to apply best practice erosion control measures to completed earth works, or otherwise stabilise such works, prior to anticipated rainfall—including existing unstable, undisturbed, soil surfaces under the management or control of the building/construction works. |
| Very low | <ul style="list-style-type: none"> Land clearing limited to 8 weeks of work if rainfall is reasonably possible. Disturbed soil surfaces stabilised with minimum 60% cover ^[2] within 30 days of completion of works if rainfall is reasonably possible. Unfinished earthworks are suitably stabilised if rainfall is reasonably possible, and disturbance is expected to be suspended for a period exceeding 30 days. |
| Low | <ul style="list-style-type: none"> Land clearing limited to maximum 8 weeks of work. Disturbed soil surfaces stabilised with minimum 70% cover ^[2] within 30 days of completion of works within any area of a work site. Unfinished earthworks are suitably stabilised if rainfall is reasonably possible, and disturbance is expected to be suspended for a period exceeding 30 days. Appropriate protection of all planned garden beds is strongly recommended. |
| Moderate | <ul style="list-style-type: none"> Land clearing limited to maximum 6 weeks of work. Disturbed soil surfaces stabilised with minimum 70% cover ^[2] within 20 days of completion of works within any area of a work site. All planned garden beds protected with a minimum 75mm layer of organic <i>Mulching</i>, heavy <i>Erosion Control Blanket</i>, <i>Rock Mulching</i>, or the equivalent. Staged construction and stabilisation of earth batters (steeper than 6H:1V) in maximum 3m vertical increments wherever reasonable and practicable. Unfinished earthworks are suitably stabilised if rainfall is reasonably possible, and disturbance is expected to be suspended for a period exceeding 20 days. |
| High | <ul style="list-style-type: none"> Land clearing limited to maximum 4 weeks of work. Disturbed soil surfaces stabilised with minimum 75% cover ^[2] within 10 days of completion of works within any area of a work site. All planned garden beds protected with a minimum 75mm layer of organic <i>Mulching</i>, heavy <i>Erosion Control Blanket</i>, <i>Rock Mulching</i>, or the equivalent. Staged construction and stabilisation of earth batters (steeper than 6H:1V) in maximum 3m vertical increments wherever reasonable and practicable. The use of turf to form grassed surfaces given appropriate consideration. Soil stockpiles and unfinished earthworks are suitably stabilised if disturbance is expected to be suspended for a period exceeding 10 days. |
| Extreme | <ul style="list-style-type: none"> Land clearing limited to maximum 2 weeks of work. Disturbed soil surfaces stabilised with minimum 80% cover ^[2] within 5 days of completion of works within any area of a work site. All planned garden beds protected with a minimum 75mm layer of organic <i>Mulching</i>, heavy <i>Erosion Control Blanket</i>, <i>Rock Mulching</i>, or the equivalent. Staged construction and stabilisation of earth batters (steeper than 6H:1V) in maximum 2m vertical increments wherever reasonable and practicable. High priority given to the use of turf to form grassed surfaces. Soil stockpiles and Unfinished earthworks are suitably stabilised if disturbance is expected to be suspended for a period exceeding 5 days. |

129. All temporary earth banks, flow diversion systems, and sediment basin embankments must be machine-compacted, seeded and mulched within ten (10) days of formation for the purpose of establishing a vegetative cover, unless otherwise stated within an approved Vegetation Management Plan.
130. Unprotected slope lengths must not exceed 80m and an equivalent vertical fall of 3m prior to shutdown periods, and during the period [*insert date/month*] and [*insert date/month*].
131. Unprotected slope lengths must not exceed 80m and an equivalent vertical fall of 3m prior to specified shutdown periods or when rainfall is expected to exceed [*insert value*] within a 24 hour period, or the monthly rainfall is expected to exceed [*insert value*]. (*alternative to above*)
132. Construction and stabilisation of earth batters steeper than 6:1 (H:V) must be staged such that no more than 3 vertical-metres of any batter is exposed to runoff-producing rainfall at any instant.
133. The application of liquid or chemical-based dust suppression measures must ensure that sediment-laden runoff resulting from such measures (e.g. runoff of excess water) does not create a traffic or environmental hazard.
134. The potential erosion risk for works within drainage channels and waterways shall be based on the rating outlined in Table G4 or Table G5 as appropriate for the site conditions. [*Tables G4 and G5 presented as a default – Authorities may choose to select an alternative rating in reference to that outlined in Section 4.4 or Appendix F of this document*]

Table G4 – Erosion risk rating based on expected channel flow conditions

| Erosion risk rating | Expected flow conditions ^[1] |
|---------------------|--|
| Very Low | No rainfall or channel flow expected during plant establishment. |
| Low | Light local rainfall is expected which is likely to result in only a minor increase in channel flow above the normal dry-weather flow rate. |
| Moderate | Heavy local rainfall is expected which is likely to cause stormwater inflows into the channel and a minor increase in channel flow above the normal dry-weather flow rate. |
| High | Medium to high-velocity in-bank flows are expected during the plant establishment period that are likely to inundate unstable, disturbed or recently revegetated channel surfaces. |
| Extreme | Medium to high-velocity overbank or near bankfull channel flows are expected during the plant establishment period that are likely to inundate unstable, disturbed or recently revegetated channel surfaces. |

Note: [1] Erosion risk rating based on worst-case of the expected flow conditions.

Table G5 – Erosion risk rating based on expected daily and average monthly rainfall

| Erosion risk rating ^[1] | Expected 24hour rainfall | Average monthly rainfall |
|------------------------------------|--------------------------|--------------------------|
| Very Low | 0 to 2mm | 0 to 30mm |
| Low | 2+ to 10mm | 30+ to 45mm |
| Moderate | 10+ to 25mm | 45+ to 100mm |
| High | 25+ to 100mm | 100+ to 225mm |
| Extreme | > 100mm | > 225mm |

Note: [1] Erosion risk rating based on worst case of expected rainfall within any 24-hour period or average monthly rainfall.

135. All erosion control measures for works within drainage channels and waterways must be designed to satisfy, as a minimum, the design standard outlined in Table G6.

Table G6 – Best practice channel clearing and stabilisation requirements

| Risk ^[1] | Best practice requirements |
|---------------------|---|
| All cases | <ul style="list-style-type: none"> • All reasonable and practicable steps taken to apply best practice erosion control measures to completed channel works, or otherwise stabilise such works, prior to an anticipated increase in stream flow. |
| Very low | <ul style="list-style-type: none"> • Channel clearing limited to maximum 8 weeks of programmed work. • Disturbed soil surfaces stabilised with minimum 70% cover ^[2] within 30 days of completion of works within any constructed drainage channel or waterway. • Non-completed works stabilised if exposed, or expected to be exposed, for a period exceeding 30 days. |
| Low | <ul style="list-style-type: none"> • Channel clearing limited to maximum 6 weeks of programmed work. • Disturbed soil surfaces stabilised with minimum 70% cover ^[2] within 30 days of completion of works within any constructed drainage channel or waterway. • Non-completed channel works stabilised if exposed, or expected to be exposed, for a period exceeding 30 days. |
| Moderate | <ul style="list-style-type: none"> • Channel clearing limited to maximum 4 weeks of programmed work. • Disturbed soil surfaces stabilised with minimum 80% cover ^[2] within 10 days of completion of works within any constructed drainage channel or waterway. • Appropriate consideration given to the use of rock protection, biodegradable <i>Erosion Control Mesh</i> or the equivalent, on all erodible stream banks subject to high velocity flows. • Non-completed channel works stabilised if exposed, or expected to be exposed, for a period exceeding 20 days. |
| High | <ul style="list-style-type: none"> • Channel clearing limited to maximum 2 weeks of programmed work. • Disturbed soil surfaces stabilised with minimum 90% cover ^[2] within 5 days of completion of works within any constructed drainage channel or waterway. • Appropriate consideration given to the use of rock protection, biodegradable <i>Erosion Control Mesh</i> or the equivalent, on all erodible stream banks subject to high velocity flows. • Non-completed channel works stabilised if exposed, or expected to be exposed, for a period exceeding 10 days. |
| Extreme | <ul style="list-style-type: none"> • Channel clearing limited to maximum 1 week of programmed work. • Disturbed soil surfaces stabilised with minimum 90% cover ^[2] within 5 days of completion of works within any area of a work site. • Appropriate consideration given to the use of rock protection, biodegradable <i>Erosion Control Mesh</i> or the equivalent, on all erodible stream banks subject to high velocity flows. • Non-completed channel works stabilised if exposed, or expected to be exposed, for a period exceeding 5 days. |

Notes: [1] Erosion risk based on channel flow conditions (Table G4), or daily/monthly rainfall depth (Table G5) as directed by the relevant regulatory authority.

[2] Minimum cover requirement may be reduced if the natural cover of the immediate land is less than the nominated value, for example in arid and semi-arid areas.

G3.11 Sediment control

136. The potential safety risk of a proposed sediment trap to site workers and the public must be given appropriate consideration, especially those sediment traps located within publicly accessible areas.
137. All reasonable and practicable measures must be taken to prevent or minimise the release of sediment from the site.
138. All sediment control measures must be designed, installed, operated and maintained in accordance with the latest version of *[insert publication]*, or other approved publication.
139. All reasonable and practicable measures must be taken to trap sediment as close to its source as is possible.
140. The Applicant must ensure that sediment-laden runoff from the site is directed to an appropriate sediment control device in accordance with the required treatment standard.
141. All sediment traps must be designed, installed, operated and maintained to collect and retain the maximum quantity of sediment appropriate for the type of sediment trap.
142. Wherever reasonable and practicable, all sediment control measures (excluding de-watering and instream sediment control measures) must be designed to be effective during a minimum design storm of 0.5 times the critical 1 in 1 year ARI design storm.
143. All instream sediment control measures must be designed to be effective during those flow conditions considered appropriate by the Council.
144. All sediment control measures must be designed to satisfy, as a minimum, the design standard outlined in Table G7.

Table G7 – Sediment control standard based on soil loss rate

| Area limit (m ²) ^[1] | Soil loss rate limit (t/ha/yr) ^[2] | | | Soil loss rate limit (t/ha/month) ^[3] | | |
|---|---|--------|-----------|--|--------|-----------|
| | Type 1 | Type 2 | Type 3 | Type 1 | Type 2 | Type 3 |
| 250 | N/A | N/A | [4] | N/A | N/A | [4] |
| 1000 | N/A | N/A | All cases | N/A | N/A | All cases |
| 2500 | N/A | > 75 | 75 | N/A | > 6.25 | 6.25 |
| >2500 | > 150 | 150 | 75 | > 12.5 | 12.5 | 6.25 |

Notes: [1] Area is defined by the catchment area draining to a given location. The “area” does not include any “clean” water catchment that bypasses the sediment trap.

[2] Soil loss rate limit defines the maximum allowable soil loss rate from a given catchment area draining to a given sediment trap at any given point in time within the construction phase.

[3] Soil loss rate limit defines the maximum allowable soil loss rate from a given catchment area draining to a given sediment trap at any given point in time within a given month in those cases where the time of construction can be specified.

[4] Refer to the regulating authority for assessment procedures. The default is a Type 3 sediment trap.

145. The classification of sediment control measures (i.e. Type 1, Type 2, Type 3 or supplementary) shall be in accordance with *[insert document]*.

146. All sediment control measures implemented for the control of sediment-laden discharge from de-watering activities must be designed to satisfy, as a minimum, the discharge standard outlined in Table G8.

Table G8 – Recommended discharge standard for de-watering operations

| Site conditions | Discharge water quality standard |
|---|--|
| All cases. | <ul style="list-style-type: none"> • Take all reasonable and practicable measures to achieve a 90 percentile total suspended solids concentration not exceeding 50mg/L. |
| Soil disturbances exceeding 2500m ² , or Projects exceeding \$500,000 expenditure, or Post-storm de-watering of sediment basins. | <ul style="list-style-type: none"> • 90 percentile total suspended solids (TSS) concentration not exceeding 50mg/L. • Water pH between 6.5 and 8.5. |

147. Prior to the controlled discharge (e.g. de-watering activities from excavations and sediment basins) of any water from the site during construction, the following water quality objectives must be achieved:
- (i) total suspended solids (maximum 50mg/L, TSS);
 - (ii) turbidity (measured in NTUs maximum of 60 NTU); and
 - (iii) water pH between 6.5 and 8.5 unless otherwise required by the Council.
(*alternative to above*)
148. All Type F or Type D *Sediment Basins* must be maintained at a minimum water level between rainfall events.
149. A minimum stockpile of flocculating agents must be securely stored on-site to provide for at least three complete treatments of all chemically treated *Sediment Basins*.
150. The Applicant must ensure that on each occasion a Type F or Type D basin cannot be de-watered prior to being surcharged by a following rainfall event, a report is presented to Council [*insert name of officer and address*] identifying the circumstances and proposed amendments, if any, to the basin's operating procedures.
151. As-Constructed plans must be prepared for all constructed *Sediment Basins* and associated emergency spillways. Such plans must appropriately verify the basin's dimensions, levels and volumes comply with the approved design drawings. These plans must be submitted to [*insert name/title/authority*] within 14 calendar days of the construction of each basin.
152. All *Sediment Basins* must remain fully operational at all times until the basin's design catchment achieves the required ground coverage, or surface stabilisation in accordance with the erosion control standard.
153. An appropriately marked (e.g. painted) de-silting marker post must be installed in each sediment basin to clearly indicate the top of the sediment storage zone.
154. Settled sediment must be removed as soon as reasonable and practicable from any sediment basin if:
- (i) it is anticipated that the next storm event is likely to cause sediment to settle above the basin's sediment storage zone; or
 - (ii) the elevation of settled sediment is above the top of the basin's sediment storage zone; or
 - (iii) the elevation of settled sediment is above the basins sediment marker line.
155. Scour protection measures placed on sediment basin emergency spillways must appropriately protect the spillway chute and its side batters from scour, and must extend a minimum of 3m beyond the downstream toe of the basin's embankment.
156. Suitable all-weather maintenance access must be provided to all sediment control devices.

157. All sediment control devices (other than sediment basins) must be de-silted and made fully operational as soon as reasonable and practicable after runoff-producing rainfall, or if the sediment retention capacity of the device falls below 75% of the design retention capacity.
158. All material removed from a sediment control device during maintenance or decommissioning, whether solid or liquid, must be disposed of in a manner that does not cause ongoing soil erosion or environmental harm.

G3.12 Site rehabilitation

159. No site revegetation shall be undertaken prior to approval of a Vegetation Management Plan.
160. No site revegetation, excluding temporary revegetation conducted for purposes of erosion control, shall be undertaken prior to approval of a Vegetation Management Plan. (*alternative to above*)
161. Adequate site data, including soil data, must be obtained to appropriately plan, design, implement, and maintain site revegetation and stabilisation works.
162. A detailed landscape and rehabilitation plan for the site must be submitted to Council for approval prior to initial land clearing or bulk earthworks.
163. A minimum 60% ground cover must be achieved on all non-completed earthworks exposed to accelerated soil erosion if further construction activities or soil disturbances are likely to be suspended for more than 30 days during those months when the expected rainfall erosivity is less than 60; minimum 70% cover within 30 days if between 60 and 100; minimum 70% cover within 20 days if between 100 and 285; minimum 75% cover within 10 days if between 285 and 1500; and minimum 80% cover within 5 days if greater than 1500. (*alternative to conditions contained in Tables G3 and G6*)
164. A minimum 60% ground cover must be achieved on all non-completed earthworks exposed to accelerated soil erosion if further construction activities or soil disturbances are likely to be suspended for more than 30 days during those months when the expected rainfall is less than 30mm; minimum 70% cover within 30 days if between 30 and 45mm; minimum 70% cover within 20 days if between 45 and 100mm; minimum 75% cover within 10 days if between 100 and 225mm; and minimum 80% cover within 5 days if greater than 225mm. (*alternative to above*)
165. All unstable or disturbed soil surfaces must be adequately stabilised against erosion (minimum 70%) prior to commencement of use, or survey plan endorsement.
166. All disturbed areas must be rendered erosion resistant by turfing, mulching, paving or otherwise suitably stabilised within [*insert number of days*] days of completion of earthworks within any given area or sub-area.
167. No completed earthwork surface shall remain denuded for longer than 60 days.
168. Unless otherwise directed within an approved Landscape Plan or Vegetation Management Plan, topsoil must be placed at a minimum depth of 75mm on slopes 4:1 (H:V) or flatter, and 50mm on slopes steeper than 4:1.
169. All cut and fill earth batters less than 3m in elevation must be topsoiled, and grass seeded/hydromulched within 10 days of completion of grading.
170. All cut and fill earth batters greater than 3m in elevation must be topsoiled, and grass seeded/hydromulched in stages not exceeding 3 vertical-metres.

171. The pH level of topsoil must be appropriate to enable establishment and growth of specified vegetation prior to initiating the establishment of vegetation.
172. Soil ameliorants must be added to the soil in accordance with an approved Landscape Plan, Vegetation Management Plan, and/or soil analysis.
173. Surface soil density, compaction and surface roughness must be adjusted prior to seeding/planting in accordance with an approved Landscape Plan, Vegetation Management Plan, and/or soil analysis.
174. Procedures for initiating a site shutdown, whether programmed or un-programmed, must incorporate revegetation of all soil disturbances unless otherwise approved by Council. The stabilisation works must not rely upon the longevity of non-vegetated erosion control blankets, or temporary soil binders.
175. Revegetation procedures associated with a programmed site shutdown must commence at least 30 days prior to the nominated shutdown time.

G3.13 Sediment basin rehabilitation

176. Procedures for the staged rehabilitation of all sediment basins must be provided within the supporting documentation of the ESCP and/or as technical notes within the ESCP.
177. In all cases where a construction phase sediment basin is to be transformed into a permanent component of the site's stormwater management system (e.g. detention/retention basin, wetland or bioretention/biofiltration system), then the required protection of the permanent system from sedimentation during the construction and maintenance phases of the development must be resolved in consultation with the proposed long-term asset owner/manager.
178. In all cases where a construction phase sediment basin is to be transformed into a permanent component of the site's stormwater management system (e.g. detention/retention basin, wetland or bioretention/biofiltration system), then the required protection of the permanent system from sedimentation during the construction, maintenance, and building phases of the development must be resolved in consultation with the proposed long-term asset owner/manager. (alternative to above)
179. Required drainage, erosion and sediment control measures during the decommissioning and rehabilitation or a sediment basin must comply with same standards specified for the normal construction works.
180. Upon decommissioning of a sediment basin, all water and sediment must be removed from the basin prior to removal of the embankment (if any). Any such material, liquid or solid, must be disposed of in a manner that will not create an erosion or pollution hazard.
181. A basin's catchment conditions associated with the staged decommissioning of the basin from a Type 1 to a Type 2 sediment trap must comply with the specified sediment control standard.
182. If an alternative, permanent, outlet structure is to be constructed prior to stabilisation of the up-slope catchment area, then this outlet structure must not be made operational if it will adversely affect the required operation of the sediment basin.
183. The permanent stormwater treatment features (e.g. vegetation and filtration media) must be appropriately protected from the adverse effects of sediment runoff in accordance with the requirements of the proposed asset manager.

184. A sediment basin must not be decommissioned until all up-slope site stabilisation measures have been implemented and are appropriately working to control soil erosion and sediment runoff in accordance with the specified ESC standard.
185. Immediately prior to the construction of the permanent stormwater treatment device, appropriate flow bypass conditions must be established to prevent sediment-laden water entering the device.
186. Immediately following the construction of the filter media of the permanent stormwater treatment device, the filter media must be covered by heavy-duty filter cloth (minimum bidum A44 or equivalent) and a minimum 200mm layer of earth or sacrificial filter media. Such earth and filter cloth must not be removed from the device until suitable surface conditions being achieved within the basin's catchment area.
187. The minimum sediment control standard for the protection of the permanent stormwater treatment device during the construction phase is a Type 2 sediment trap.
188. The minimum sediment control standard for the protection of the permanent stormwater treatment device during the construction and maintenance phases is a Type 2 sediment trap. (alternative to above)
189. Plant establishment within the permanent stormwater treatment device must be delayed until sediment intrusion into the device is suitably under control.
190. Upon suitable conditions being achieved within the basin's catchment area, the operational features of the permanent stormwater treatment system must be made fully operational (i.e. maintenance and/or reconstruction as required).
191. The permanent stormwater treatment features of the rehabilitated basin must not be made operational until all up-slope site stabilisation measures have been implemented and are appropriately working to control soil erosion and sediment runoff in accordance with the specified ESC standard. (alternative to above)
192. Upon the approval of *[insert authority]*, the newly constructed permanent stormwater treatment features of the basin may be made operational if such actions do not prevent the site from operating at the required sediment control standard. (alternative to above)

G3.14 Site monitoring

193. The Applicant must ensure that appropriate procedures and personnel are engaged to plan and conduct site inspections and water quality monitoring throughout the construction and maintenance phase (including as appropriate, pre-construction monitoring) that is commensurate with the site's environmental risk.
194. All ESC measures must be inspected:
 - (i) at least daily (when work is occurring on-site); and
 - (ii) at least weekly (when work is not occurring on-site); and
 - (iii) within 24 hours of expected rainfall; and
 - (iv) within 18 hours of a rainfall event of sufficient intensity and duration to cause runoff on the site).
195. During period of water discharge from the site, water quality samples must be collected at each monitoring station at least once on each calendar day until such discharge stops.
196. All site monitoring data including rainfall records, dates of water quality testing, testing results and records of controlled water releases from the site, must be

kept in an on-site register. The register is to be maintained up to date for the duration of the approved works and be available on-site for inspection by Council officers on request.

197. At nominated instream water monitoring stations, a minimum of 3 water samples must be taken and analysed, and the average result used to determine quality.
198. Sediment basin water quality samples must be taken at a depth no greater than 200mm above the top surface of the settled sediment within the basin.
199. The Applicant must ensure the implementation and maintenance of a system that monitors and records site compliance and non-compliance with the erosion and sediment control (ESC) approval requirements. This system must as a minimum incorporate regular site audits. Such audits must be:
 - (i) undertaken by a person suitably qualified and experienced in erosion and sediment control that can be verified by an independent third party (this person must not be an employee or agent of the principal contractor); and
 - (ii) conducted on the next business day following a rainfall event in which greater than 10mm of rainfall has been recorded by the Bureau of Meteorology rain gauge nearest to the site; and
 - (iii) conducted at intervals of not more than one (1) calendar month commencing from the day of site disturbance until all disturbed areas have been adequately stabilised against erosion to the acceptance of Council; and
 - (iv) conducted using the Site Inspection Checklist presenting in (*insert publication*) as amended from time to time.
200. The Applicant must provide Council [*insert officer*] with a report at intervals of no less than every two months, starting from the commencement of site works, and up until all disturbed areas have been adequately stabilised against erosion to the acceptance of the Council. The report must include as a minimum for that review period:
 - (i) copies of all original Site Inspection Checklists; and
 - (ii) non-conformance and corrective action reports;
 - (iii) sediment basin water quality and site discharge water quality monitoring results;
 - (iv) a plan showing the areas of completed soil stabilisation; and
 - (v) rainfall records including date and rainfall depth.
201. Within fourteen (14) days of completing each hydromulch, Bonded Fibre Matrix or Compost Blanket application, the Applicant must obtain in writing from the mulching contractor, certification that the application complies with [*insert standard*].
202. All environmental incidents must be recorded in a field log that must remain accessible to all relevant regulatory authorities on request.

G3.15 Site maintenance

203. All ESC measures must be maintained in proper working order at all times during their required operational life, including hydraulic capacity and operational effectiveness.
204. All necessary ESC measures must be maintained in proper working order at all times during the project's "maintenance period".
205. All temporary ESC measures must be removed after the satisfactory completion of an "off-maintenance" inspection by Council and prior to formal acceptance of "off-maintenance" by Council.

206. Maintenance of ESC measures must occur in accordance with Table G9:

Table G9 – Maintenance requirements of ESC measures

| ESC Measure | Maintenance Trigger | Timeframe |
|--------------------|--|--|
| Sediment basins | When settled sediment exceeds the volume of the sediment storage zone. | Within 7 days of the inspection. |
| Other ESC measures | The capacity of ESC measures falls below 75%. | By end of the day during any stay in rainfall. |

207. All materials removed from ESC devices during maintenance, whether solid or liquid, must be disposed of in a manner that does not cause ongoing soil erosion or environmental harm.
208. Poisoning of excess vegetation in drainage lines must not be undertaken, except under the specific approval of Council.
209. Washing/flushing of streets shall only occur where sweeping has failed to remove sufficient sediment and there is a compelling need to remove the remaining sediment (e.g. for safety reasons). In such circumstances, all reasonable and practicable sediment control measures must be used to prevent, or at least minimise, the release of sediment into receiving waters. Only those measures that will not cause safety issues or adverse property flooding to third parties shall be employed.
210. Where it is necessary to clear excess vegetation in order to restore the water carrying capacity of open drains, the vegetation must be selectively cut and trimmed so as to leave a short, dense, live ground cover for the purpose of minimising soil erosion.
211. Maintenance mowing of all road shoulders, table drains, batters and other surfaces likely to experience accelerated soil erosion must aim to leave the grass length no shorter than 50mm where reasonable and practicable.
212. Maintenance mowing must be done in a manner that will not damage the profile of formed, soft edges, such as the crest of earth embankments.
213. The applicant must ensure that it is clearly defined and documented who is the “responsible person/authority” for maintaining those ESC measures that are installed during the subdivision phase but which are required to be operational during the subsequent building phase. Where there is no documented description of who is responsible, responsibility for maintenance shall rest with the applicant.
214. Responsibility for maintenance for ESC measures that Council has “accepted on maintenance” shall remain with the Applicant up until the works are declared to be “off-maintenance” by Council.
215. The Applicant must ensure that the principal contractor keeps written records of ESC monitoring and maintenance activities conducted during the construction and maintenance periods, and be able to present and/or provide original copies of such records to Council officers on request.

G3.16 Road works

216. Vegetation removed during road works must be re-used to the maximum possible extent to minimise short and long-term soil erosion. Non-salvageable debris must be disposed of in a manner that does not cause ongoing environmental harm.

217. Soil disturbances must be staged into manageably-sized areas of no greater than ten (10) hectares to ensure adequate ESC management and progressive stabilisation of disturbed surfaces.
218. Newly constructed spray-sealed roads must be swept thoroughly as soon as possible after gravelling to prevent excess gravel entering stormwater drains or waterways.
219. During the construction period, all unstable fill embankments are to be left with a lip (windrow) at the top of the slope at the end of each day's operation, or other appropriate drainage control measures, to prevent bank erosion.
220. All cut and fill earth batters are to be topsoiled, and grass seeded/hydromulched within ten (10) days of completion of grading.

G3.17 Instream works

221. The Applicant must ensure that all necessary State Government licences and permits are obtained prior to commencing instream works, including licences/permits for the disturbance to native vegetation.
222. Prior to the commencement of any construction activity, or soil disturbance, the Applicant must prepare, and make available to Council, written procedures of dealing with *Incidents, Emergencies and Complaints*.
223. Prior to the commencement of any construction activity, or soil disturbance, the Applicant must prepare, and make available to Council, written procedures for the management of wildlife, terrestrial and aquatic passage.
224. Terrestrial and aquatic passage must be maintained along the waterway at all times and in accordance with State and Council guidelines.
225. The design of instream structures must give appropriate consideration to the aim of reducing the potential impact of associated instream maintenance activities.
226. Disturbance to natural watercourses (including bed and banks) and their associated riparian zones must be limited to the minimum necessary to complete the approved works.
227. To the maximum degree reasonable and practicable, all instream disturbances must be programmed to occur during the least erosive periods of the year.
228. To the maximum degree reasonable and practicable, all instream disturbances must be programmed to occur during periods of least impact on fish migration.
229. Priority must be given to the safe and effective diversion of instream flows around instream disturbances rather than the use of instream sediment control measures.
230. The Applicant must ensure an adequate supply of erosion control, sediment control, and appropriate pollution clean-up materials are available on-site during the construction period.
231. The number, width, and extent of temporary watercourse crossings must be reduced to the absolute minimum necessary to complete the works.
232. The choice of temporary watercourse crossing must be of a type, location, and size that causes the least overall damage to the environment given appropriate consideration to its installation, operation, and removal.
233. All temporary watercourse crossings, including their approach roads, must employ appropriate drainage, erosion, and sediment controls to minimise sediment inflow into the watercourse.
234. To the maximum degree reasonable and practicable, access tracks, whether temporary or permanent, must be located a distance from the top of bank of at

least 30m, or the width of the stream (measured at the top of the bank), whichever is the lesser.

235. No erodible material shall be stockpiled within 40m of the top of the bank, unless otherwise approved by Council.
236. All petroleum-based equipment (i.e. vehicles and motors) located within bed and bank regions of the waters must be inspected on a daily basis.
237. All materials blown onto the water surface must be collected and secured as soon as practicable.
238. All site activities must be inspected prior to forecast rain, daily during extended periods of rainfall, after runoff-producing rain, and at least weekly throughout the construction and maintenance periods.
239. Synthetic reinforced erosion control mats and blankets must not be placed within, or adjacent to, riparian zones and watercourses if such materials are likely to cause environmental harm to wildlife or wildlife habitats.

G3.18 Works within intertidal areas

240. The Applicant must ensure that all necessary State Government licences and permits are obtained prior to commencing instream works, including licences/permits for the disturbance to marine vegetation.
241. To the maximum degree reasonable and practicable, the Applicant must ensure disturbance to aquatic vegetation, particularly seagrasses and mangroves, is minimised.
242. No erodible material shall be stockpiled within 40m from the high tide mark, unless approved by Council.
243. The Applicant shall take all appropriate steps to ensure sediment deposition within the voids between natural and introduced rock located within the tidal zone is minimised.
244. The Applicant shall take all appropriate steps to ensure that all equipment is washed down (cleaned) well away from the water's edge, and in a manner that prevents sediment-laden or otherwise polluted water entering the waterway.
245. All waste receptors must be sealed and/or covered outside working hours to prevent the entry of water and vermin, or wind disturbance of the contained material.
246. Drip pans must be placed under all vehicles and motorised equipment placed on docks, barges, or other structures that extend over water bodies if the vehicle or equipment is expected to be idle for more than 1 hour.
247. All barges must be fitted with watertight curbs or toe boards to contain spills and prevent materials, tools, and debris from leaving the barge.
248. The Applicant must take all reasonable and practicable measures to ensure that vehicle (amphibious or terrestrial) damage to seawalls (i.e. due to wave and wash conditions) is minimised.
249. The Applicant must ensure all appropriate measures are deployed to provide secondary containment for any spills while materials and/or equipment are being transferred on and off barges to (e.g. floating sediment curtains).
250. The Applicant must ensure all materials being transported by boats or barges are adequately secured during transportation.

G4. Model Code of Practice

Compliance with a given Performance Criterion can only be achieved by:

- (i) complying with the Acceptable Solution; or
- (ii) formulating an alternative solution which complies with the Performance Criterion, or is shown to be at least equivalent to the acceptable solutions; or
- (iii) a combination of (i) and (ii).

Unless otherwise indicated, all outcomes listed within the Acceptable Solution must be satisfied in order to comply with the Acceptable Solution.

Attachment A forms part of this Code. The Attachment provides essential information and requirements not otherwise provided within the Code.

If the scheduled works incorporate building activities, then the model Code of Practice provided in Appendix H – *Building sites* shall apply.

If the scheduled works incorporate instream soil disturbances, then the model Code of Practice provided in Appendix I – *Instream works* shall apply.

In the event of a conflict over the desired outcome of a *Performance Criterion* or an *Acceptable Solution*, then the outcome shall be that which best achieves the *objective* of the Code, that being:

To protect the environment while allowing for development that improves the total quality of life, both now and in the future, in a way that maintains the ecological processes on which life depends.

To achieve this objective a person must not carry out any activity that causes, or is likely to cause, environmental harm unless the person takes all reasonable and practicable measures to prevent or minimise the harm.

In assessing all reasonable and practicable measures, appropriate consideration must be given to:

- (i) the nature of the potential harm; and
- (ii) the sensitivity of the receiving environment; and
- (iii) the current state of technical knowledge for the activity; and
- (iv) the likelihood of successful application of the various measures that might be undertaken; and
- (v) the financial implications of the various measures relative to the type of activity.

The various recommendations presented in this guideline are an indication of what may be considered *reasonable and practicable* for the construction industry.

This model Code of Practice does not provide all the information necessary to adequately control soil erosion and sediment runoff in all situations. Users of the Code should always make their own site-specific evaluation, testing and design, and refer to their own advisers and consultants as appropriate.

Specifically, the adoption of this model Code of Practice will not necessarily guarantee:

- (i) compliance with any statutory obligations;
- (ii) avoidance of all environmental harm or nuisance.

| DEVELOPMENT PLANNING AND DESIGN | | | |
|--|---|----------------------------|--|
| Performance Criteria | | Acceptable Solution | |
| P1 | Adequate data is obtained to allow appropriate site planning and design. | A1 | <ul style="list-style-type: none"> (a) The extent and complexity of data collection is commensurate with the potential environmental risk, and the extent and complexity of the proposed soil disturbance. (b) Potential site constraints and zones of high or extreme erosion hazard are identified early in the planning phase. (c) A Conceptual Erosion and Sediment Control Plan is prepared if the construction activities are deemed to represent a high to extreme erosion hazard. |
| P2 | The design and layout of the development does not cause unnecessary soil disturbance. | A2 | <ul style="list-style-type: none"> (a) The development is appropriately integrated into the existing site conditions, including the existing topography, such that the need for extensive land reshaping and surface modifications is minimised. (b) Wherever reasonable and practicable, “cut and fill” and “slab-on-ground” construction practices are not employed on land slopes equal to, or steeper than 20%. (c) The design, staging, and layout of the development do not cause unnecessary soil disturbance if an alternative design, staging or layout (which reduces the potential environmental harm) is available that achieves the same or equivalent project outcomes at a reasonable cost. |
| P3 | The design and layout of the development minimise the risk of environmental harm occurring during the construction phase. | A3 | <ul style="list-style-type: none"> (a) Potential high-risk construction activities are identified during development planning. (b) Essential ESC control measures are appropriately integrated into the project’s planning, design and financial analysis. (c) Adequate space is provided for the construction and maintenance of essential ESC measures. (d) The development layout avoids the placement of critical structures or buildings within the region of the lowest land elevation within any sub-catchment if such a structure would prevent the construction and effective operation of essential ESC measures throughout the construction period. (e) The development’s design and layout do not cause unnecessary delays to the initiation and satisfactory completion of site stabilisation and final rehabilitation activities. |
| P4 | The design and layout of the development minimise the risk of environmental harm occurring during the operational phase of the development. | A4 | <ul style="list-style-type: none"> (a) The development is designed to appropriate drainage standards (permanent drainage works). (b) Ongoing erosion problems at the inlet and outlet of permanent drainage systems (pipes or channels) are minimised. (c) The development incorporates current best practice stormwater quality controls for the operational phase of the development. (d) The development design and layout appropriately recognises and integrates identified site constraints. |

| | | | |
|-----------|---|-----------|---|
| | | | (e) To the maximum degree reasonable and practicable, disturbance to deep-rooted vegetation on slopes susceptible to mass movement is minimised, if not totally avoided. |
| P5 | The design and layout of the development minimise the risk of environmental harm to downstream waterways. | A5 | (a) All reasonable and practicable measures are taken to minimise changes to the natural water cycle (including volume, frequency, duration and velocity of stormwater runoff) during the operational phase of the development. (b) The number of temporary and permanent watercourses crossing is reduced to the minimum necessary. |

| CONSTRUCTION PLANNING | | | |
|------------------------------|--|----------------------------|--|
| Performance Criteria | | Acceptable Solution | |
| P6 | Adequate site data is obtained to allow appropriate construction planning. | A6 | (a) Zones of high to extreme erosion hazard are identified prior to construction planning. (b) The extent and complexity of site data, including soil mapping, is commensurate with the potential environmental risk, and the extent and complexity of the soil disturbance. |
| P7 | Construction planning aims to minimise the risk of environmental harm occurring during the construction phase. | A7 | (a) Development of the Erosion and Sediment Control Plan is an integral part of construction planning. (b) High-risk construction activities are identified during construction planning. (c) High-risk construction activities and disturbances of high to extreme erosion hazard areas are minimised, if not totally avoided, especially during periods of high to extreme erosion potential. (d) All reasonable and practicable measures are taken to design/plan the construction layout, programming, staging and methodology to minimise environmental risks associated with high-risk construction activities. (e) Construction planning minimises the duration that any and all areas of soil will be exposed to the erosive effects of wind, rain and flowing water, in part through the progressive and prompt stabilisation of disturbed areas. (f) Construction site layout, methodology, staging and programming do not cause unnecessary environmental harm if an alternative layout, methodology, staging or program (which reduces unnecessary soil disturbance and/or potential environmental harm) is available that achieves the same or equivalent project outcomes at a reasonable cost. (g) On sites with a soil disturbance greater than 2500m ² , a Water Quality Monitoring Program, and Site Stabilisation Plan, Landscape Plan, and/or Vegetation Management Plan is prepared and approved by the relevant regulatory authority prior to site establishment. |

| | | | |
|-----------|--|-----------|--|
| P8 | Construction planning aims to minimise the risk of environmental harm to downstream waterways. | A8 | <p>(a) To the maximum degree reasonable and practicable, instream disturbances are programmed to occur during the least erosive and environmentally damaging periods of the year.</p> <p>(b) The number of temporary watercourse crossings is minimised.</p> |
|-----------|--|-----------|--|

| EROSION AND SEDIMENT CONTROL PLAN (ESCP) | | | |
|---|--|----------------------------|--|
| Performance Criteria | | Acceptable Solution | |
| P9 | An Erosion and Sediment Control Plan (ESCP) is prepared prior to site disturbance that provides sufficient information to achieve the required environmental protection. | A9 | <p>(a) The design standard of drainage, erosion and sediment controls comply with the requirements of the relevant regulatory authority, or where such a standard does not exist, are designed in accordance with current best practice.</p> <p>(b) As a minimum, the ESC design standard applied to a site at any given instant is commensurate with the degree of environmental risk, and the type, cost, and scope of the proposed works.</p> <p>(c) The level of information and detail supplied in the ESCP is commensurate with the potential environmental risk and the complexity of the proposed works; and of sufficient clarity to allow on-site personnel to appropriately implement the plan.</p> |
| P10 | The ESCP is prepared by, or under the supervision of, suitably qualified and experienced personnel. | A10 | <p>(a) The qualifications and experience of the personnel preparing and/or supervising the preparation of the ESCP is commensurate with the potential environmental risk, and the extent and complexity of the soil disturbance.</p> <p>(b) The design of each sediment basin is signed off by a suitably qualified and experienced professional.</p> <p>(c) On sites with a soil disturbance greater than 2500m², the ESCP is signed off by a suitably qualified and experienced professional.</p> <p>(d) On sites with a soil disturbance greater than one (1) hectare, or where the ESCP incorporates a sediment basin, the ESCP is signed off by an engineer experienced in hydrology and hydraulics.</p> <p>(e) Where the ESCP incorporates a sediment basin with a constructed earth embankment with a height greater than one (1) metre, the ESCP is signed off by an appropriate geotechnical specialist.</p> |
| P11 | The ESCP is appropriate for the site conditions and the potential environmental risk. | A11 | <p>(a) The extent and complexity of data collected prior to finalisation of the ESCP is commensurate with the potential environmental risk, and the extent and complexity of the soil disturbance.</p> <p>(b) In preparation of the ESCP, priority is given to the prevention, or at least the minimisation, of soil erosion, rather than just the trapping of displaced sediment.</p> |

| | | | |
|------------|--|------------|---|
| | | | (c) The stormwater drainage requirements of the construction phase are appropriately integrated into the ESCP through the use of best-practice drainage control measures and design standards. |
| P12 | The ESCP remains relevant, at all times, to the current site conditions. | A12 | (a) The ESCP remains both effective and flexible, and is based on anticipated soil, weather, and construction conditions (as may vary from time to time). (b) The ESCP is appropriately amended if the implemented works fail to achieve the “objective” of the ESCP, the required performance standard, or the State’s environmental protection requirements. (c) Once the works commence, a revised ESCP is prepared should the works not be completed within twelve (12) months, with further reviews undertaken thereafter at half-yearly intervals. (d) All amended ESCPs are prepared by, or under the supervision of, suitably qualified and experienced personnel. |
| P13 | Potential harm to wildlife as a result of ESC measures is minimised. | A13 | Synthetic (plastic) reinforced fabrics are not specified within, or adjacent to, bushland areas, riparian zones and watercourses if such materials are likely to cause harm to wildlife or wildlife habitats. |

SITE ESTABLISHMENT

| Performance Criteria | | Acceptable Solution | |
|-----------------------------|--|----------------------------|---|
| P14 | Site personnel are provided with all necessary information prior to site establishment. | A14 | (a) The Development Approval Conditions, Development Permit, Erosion and Sediment Control Plan, Monitoring and Maintenance Program, Landscape and/or Site Rehabilitation Plan, and any other document required for the management of soil erosion and sediment control, are provided to the principal contractor prior to the commencement of land disturbing activities. (b) On sites with a soil disturbance greater than one (1) hectare, a Vegetation Management Plan, and procedures for conducting a site shutdown (whether programmed or unprogrammed), are provided to the principal contractor prior to the commencement of land disturbing activities. |
| P15 | Appropriate personnel are engaged to implement and monitor all necessary ESC measures prior to commencement of site disturbance. | A15 | (a) Prior to the commencement of any construction activities or soil disturbance, appropriately trained and experienced personnel are engaged to undertake regular ESC audits of the site. (b) Prior to commencement of site works, a “chain of command” in relation to the implementation, modification, and maintenance of Erosion and Sediment Control measures is established. |
| P16 | Site establishment does not cause unnecessary soil disturbance or environmental harm. | A16 | (a) No land-disturbing activities occur on the site until all perimeter ESC measures, sediment traps, and associated temporary drainage controls, have been constructed in accordance with the ESCP and best practice erosion and sediment control. |

| | | | |
|------------|--|------------|--|
| | | | <p>(b) All site office facilities and operational activities are located such that all effluent, including wash-down water, can be totally contained and treated within the site.</p> <p>(c) Adequate waste collection areas/bins are provided on-site and maintained such that environmental harm is minimised.</p> |
| P17 | Site access is appropriately managed to minimise the risk of environmental harm. | A17 | <p>(a) Authorised site access is confined to the minimum practicable number of locations.</p> <p>(b) Access onto the site, where authorised or unauthorised, is appropriately managed to minimise the risk of sediment being tracked onto adjoining sealed roadways.</p> <p>(c) All reasonable and practicable measures are taken to ensure stormwater runoff from access roads and stabilised entry/exit systems, drains to an appropriate sediment control device.</p> |

| SITE MANAGEMENT | | | |
|-----------------------------|--|----------------------------|--|
| Performance Criteria | | Acceptable Solution | |
| P18 | The work site is managed such that environmental harm is minimised. | A18 | <p>(a) No land-disturbing activities are undertaken prior to appropriate consideration being given to erosion and sediment control issues.</p> <p>(b) All works subject to an Erosion and Sediment Control Plan (ESCP) are carried out in accordance with the ESCP (as amended from time to time) unless circumstances arise where compliance with the ESCP would increase the potential for environmental harm as assessed by a recognised authority.</p> <p>(c) All ESC measures are installed, operated and maintained in accordance with current best management practice.</p> <p>(d) Land-disturbing activities are undertaken in such a manner that allows all reasonable and practicable measures to be undertaken to:</p> <ul style="list-style-type: none"> (i) allow stormwater to pass through the site in a controlled manner and at non-erosive flow velocities; and (ii) minimise soil erosion resulting from wind, rain and flowing water; and (iii) minimise the duration that disturbed soils are exposed to the erosive forces of wind, rain and flowing water; and (iv) prevent, or at least minimise, environmental harm (including public nuisance and safety issues) resulting from work-related soil erosion and sediment runoff. <p>(e) Site spoil is lawfully disposed of in a manner that does not result in ongoing soil erosion or environmental harm.</p> |
| P19 | Those responsible for erosion and sediment control are appropriately trained and equipped. | A19 | Site managers and/or the nominated responsible ESC personnel achieve and maintain a good working knowledge of the correct installation and operational procedures of all ESC measures used on the site. |

| | | | |
|------------|--|------------|--|
| P20 | Disturbance to ESC measures by on-site personnel is minimised. | A20 | <p>(a) On-site personnel are appropriately instructed and educated as to the purpose and operation of adopted drainage, erosion and sediment control (ESC) measures, and the need to maintain such measures in proper working order at all times.</p> <p>(b) Unnecessary disturbance to ESC measures by on-site personnel, sub-contractors and construction traffic (including site management and material delivery vehicles) is minimised.</p> |
| P21 | The adopted ESC measures remain relevant at all times to the current site conditions. | A21 | <p>(a) Performance of the site's ESC measures is monitored in accordance with the site's Monitoring and Maintenance Program.</p> <p>(b) The adopted erosion and sediment control measures are appropriately amended if site conditions significantly change, or are expected to significantly change, from those conditions assumed during development of the ESCP.</p> <p>(c) The adopted erosion and sediment control measures are appropriately amended if the implemented works fail to achieve the "objective" of the ESCP, or the required performance standard, or the State's environmental protection requirements, or unacceptable environmental harm is occurring or is likely to occur.</p> <p>(d) In circumstances where addition or alternative erosion and sediment control measures are required on a site, and a revised ESCP needs to be prepared, then only those works necessary to minimise environmental harm are conducted prior to preparation of the revised ESCP.</p> |
| P22 | The work site is appropriately prepared for imminent construction activities and weather conditions. | A22 | <p>(a) Adequate supplies of drainage, erosion and sediment control, and relevant pollution clean-up materials, are retained on-site during the construction period.</p> <p>(b) Appropriate short-term drainage control measures (e.g. flow diversion around recently opened trenches and excavations) are installed and operational prior to impending storms.</p> <p>(c) A minimum stockpile of flocculating agents are securely stored on-site to provide for at least three complete treatments of all chemically treated sediment traps.</p> |
| P23 | Land disturbing activities do not cause unnecessary soil disturbance. | A23 | <p>(a) Land-disturbing activities do not cause unnecessary soil disturbance if an alternative construction process (that reduces potential environmental harm) is available that achieves the same or equivalent project outcomes at a reasonable cost.</p> <p>(b) The extent of unnecessary soil disturbance, including disturbances outside the designated work area, is minimised.</p> |
| P24 | Damage to retained or protected vegetation is minimised. | A24 | <p>(a) Prior to the commencement of land disturbing activities within any given area, all protected vegetation and significant areas of retained vegetation within that area, are appropriately identified to minimise the risk of disturbance to such areas.</p> |

| | | | |
|------------|--|------------|---|
| | | | (b) No damage is allowed to occur to roots, trunk or branches of “retained” vegetation, unless under the direction of an appropriate Vegetation Management Plan. |
| P25 | Adopted work practices minimise the release of pollutants into receiving waters. | A25 | <p>(a) Emergency and pollution control procedures are commensurate with the site conditions, local environmental values, and the type, cost, scope and complexity of the works.</p> <p>(b) All liquid chemicals, including petroleum products, that could potentially be washed or discharged from the site in association with sediment, are stored and handled on-site in accordance with relevant standards such as AS1940.</p> <p>(c) Cement-laden runoff, concrete waste, and chemical products (including petroleum and oil-based products), are managed on-site in accordance with current best management practice.</p> <p>(d) Brick-, tile- and masonry-cutting activities are carried out in accordance with current best management practice.</p> <p>(e) Washing of tools and painting equipment is carried out in accordance with current best management practice.</p> <p>(f) Newly sealed hard-stand areas (e.g. roads, driveways and car parks) are swept thoroughly as soon as practicable after surfacing to minimise the risk of components of the surfacing compound (e.g. bitumen and gravel) entering stormwater drains.</p> <p>(g) All pollutants washed or blown from the site are collected and secured as soon as practicable.</p> |
| P26 | The application of liquid or chemical-based dust suppression measures does not cause an environmental hazard. | A26 | <p>(a) The application of dust suppression measures complies with State approved environmental controls and manufacturer’s instructions (whichever is the most restrictive or environmentally conservative).</p> <p>(b) Vegetation watering and dust suppression activities are conducted in a manner that ensures sediment-laden runoff from such activities does not create a traffic or safety hazard.</p> |
| P27 | Environmental harm, safety issues, and nuisance or damage to public and private property resulting from off-site sediment deposits, material spills, and/or the adopted ESC measures is minimised. | A27 | <p>(a) Sediment and other material originating from the work area, or as a result of the transportation of materials to or from the work area, that collects on sealed roads, or within gutters, drains or waterways outside the immediate work area, is removed:</p> <ul style="list-style-type: none"> (i) immediately if rain is occurring or imminent; or (ii) immediately if considered a safety hazard; or (iii) if items (i) or (ii) do not apply, as soon as practicable, but before completion of the day’s work. <p>(b) Washing/flushing of sealed surfaces only occurs where sweeping has failed to remove sufficient sediment, and there is a compelling need to remove the remaining sediment (e.g. for safety</p> |

| | | | |
|------------|--|------------|--|
| | | | <p>reasons).</p> <p>(c) Sediment deposits that cause nuisance to, or adversely affect the use or value of, neighbouring properties are removed and the area rehabilitated as soon as practicable.</p> <p>(d) The adopted ESC measures do not adversely affect drainage or flooding conditions within neighbouring properties.</p> |
| P28 | Potential safety risks to site workers and the public as a result of ESC measures are minimised. | A28 | <p>(a) Operational safety issues (public and site personnel) are given appropriate consideration during the installation, operation, maintenance and removal of ESC measures.</p> <p>(b) Publicly accessible sediment basins are fenced (i.e. exclusion fencing) where there is considered to be an unacceptable safety risk.</p> |
| P29 | Potential harm to wildlife as a result of ESC measures is minimised. | A29 | <p>(a) Disturbance to wildlife habitats is limited to the minimum necessary to complete the approved works.</p> <p>(b) Large sediment traps allow appropriate egress of wildlife where such wildlife could enter the trap.</p> <p>(c) Synthetic (plastic) reinforced fabrics are not placed within, or adjacent to, bushland areas, riparian zones, and watercourses if such materials are likely to cause harm to wildlife or wildlife habitats.</p> |
| P30 | Disturbance to natural watercourses is minimised. | A30 | <p>(a) Instream works are conducted in accordance with an approved Code of Practice for instream works.</p> <p>(b) No instream land-disturbing activities are undertaken prior to development of a Vegetation Management Plan.</p> <p>(c) Disturbance to natural watercourses (including bed and bank vegetation) and their associated riparian zones is limited to the minimum necessary to complete the approved works.</p> <p>(d) The number, location, type, and size of temporary watercourse crossing are such that the overall adverse impact on the environment is minimised.</p> <p>(e) All temporary watercourse crossings, including their approach roads, employ appropriate drainage, erosion and sediment controls to minimise sediment inflow into the watercourse.</p> |
| P31 | Site shutdowns are conducted in a manner that minimises potential environmental harm. | A31 | <p>(a) Procedures for initiating a site shutdown incorporate appropriate revegetation of all soil disturbances unless otherwise stipulated within an approved site management plan.</p> <p>(b) Revegetation procedures associated with a programmed site shutdown commence at least 30 days prior to the nominated shutdown time.</p> <p>(c) Adopted site stabilisation measures do not rely upon the longevity of non-vegetated erosion control blankets and short-term soil binders.</p> |

| LAND CLEARING | | | |
|-----------------------------|--|----------------------------|--|
| Performance Criteria | | Acceptable Solution | |
| P32 | Potential environmental harm resulting from land clearing is minimised. | A32 | <p>(a) All land clearing is conducted in accordance with State and local government Vegetation Protection and/or Preservation requirements and/or policies.</p> <p>(b) On sites with a soil disturbance greater than one (1) hectare, no land clearing is undertaken prior to approval of a Vegetation Management Plan.</p> <p>(c) Limits on the extent and duration of soil disturbance are commensurate with the potential erosion risk and/or erosion hazard.</p> <p>(d) Compliance with Performance Criterion P24.</p> |
| P33 | Land clearing is limited to the minimum necessary. | A33 | <p>(a) Land clearing does not cause unnecessary soil disturbance if an alternative process (which reduces the potential environmental harm) is available that achieves the same or equivalent project outcomes at a reasonable cost.</p> <p>(b) Land clearing at any given time during periods of potential soil erosion is restricted to only those areas required for the current stage of works.</p> <p>(c) Wherever reasonable and practicable, land clearing is limited to 5m from the edge of proposed constructed works, 2m of essential construction traffic routes, and a total of 10m width for construction access.</p> |
| P34 | Soil erosion during and following land clearing is minimised. | A34 | <p>(a) Land clearing within any sub-area is delayed as long as reasonable and practicable.</p> <p>(b) Land clearing and site rehabilitation are staged to minimise the extent and duration that any and all areas of soil are exposed to the erosive effects of wind, rain and flowing water.</p> <p>(c) If tree clearing is required well in advance of future earthworks, then tree clearing methods that will minimise potential soil erosion are employed, especially in areas of high to extreme erosion risk.</p> |
| P35 | Sediment releases to receiving water (within or outside the site) are minimised during land clearing operations. | A35 | <p>(a) No land clearing is undertaken unless preceded or accompanied by the installation of adequate drainage and sediment control measures.</p> <p>(b) No part of a sediment basin catchment area is grubbed of vegetation, or stripped of topsoil, until the basin is constructed and fully operational.</p> |

| SOIL AND STOCKPILE MANAGEMENT | | | |
|--------------------------------------|---|----------------------------|--|
| Performance Criteria | | Acceptable Solution | |
| P36 | The “soil structure” of soils that are to be revegetated is not unnecessarily damaged. | A36 | Soils that are to be revegetated are not unnecessarily disturbed when they are either too wet, or too dry. |
| P37 | Maximum benefit is obtained from existing topsoil. | A37 | (a) The topsoil is managed (i.e. stripped, treated, stockpiled and reused) in accordance with the recommendations of an approved Vegetation Management Plan or similar. OR (b) Topsoil is stripped, stockpiled, placed, and where necessary treated, in accordance with current best practice. AND (c) Topsoil originating from the site is respread as the topsoil to maximise erosion control and revegetation, except where it has been assessed that such soil will not improve erosion control and/or revegetation on the site. |
| P38 | Environmental harm caused by the temporary stockpiling of erodible material is minimised. | A38 | Stockpiles of erodible material are: (i) located fully within the relevant property; (ii) appropriately protected from wind, rain and excessive surface flows in accordance with current best practice; and (iii) located at least 2m from hazardous areas, retained vegetation, and overland flow paths; and (iv) located up-slope of an appropriate sediment control system. |
| P39 | Exposed dispersive soils are managed such that the risk of ongoing soil erosion is minimised. | A39 | Construction details for drainage systems and bank stabilisation works within dispersive soil areas clearly demonstrate how these soils will be managed to prevent future erosion problems. |
| P40 | Exposed potential acid sulfate soils are appropriately managed. | A40 | (a) If acid sulfate soils conditions exist on site, then appropriate warnings are placed on the ESCP. (b) All exposed actual or potential acid sulfate soils are managed in accordance with current best practice. (c) On-site personnel involved in the disturbance of actual or potential acid sulfate soils are appropriately trained and/or supervised. |

| DRAINAGE CONTROL | | | |
|-----------------------------|--|----------------------------|---|
| Performance Criteria | | Acceptable Solution | |
| P41 | Temporary drainage control measures are designed, constructed and maintained to an appropriate standard. | A41 | <p>(a) The standard of drainage control complies with the requirements of the relevant regulatory authority, or where such a standard does not exist, drainage controls are designed in accordance with current best practice.</p> <p>(b) Stormwater drainage during each stage of earth works is managed in accordance with the appropriate ESCP or Construction Drainage Plan (as amended from time to time).</p> <p>(c) All drainage channels, whether temporary or permanent, are constructed and maintained (at all times) with sufficient size, gradient and surface conditions to maintain their required hydraulic capacity.</p> <p>(d) The adopted drainage control measures remain relevant, at all times, to the current and imminent site conditions.</p> |
| P42 | Stormwater movement through the site is appropriately managed to minimise soil erosion. | A42 | <p>(a) If the drainage area up-slope of a soil disturbance exceeds 1500m², and the average monthly rainfall exceeds 45mm, all stormwater discharged from this area (up to the design storm) is diverted around or through the soil disturbance in a manner that minimises soil erosion.</p> <p>(b) Appropriate drainage controls are installed above an exposed earth batter to minimise soil erosion on the batter.</p> <p>(c) The spacing of cross-slope drainage systems down long exposed, non-vegetated or recently seeded slopes, does not exceed that standard set by the relevant regulatory authority, or in the absence of such standard, are designed in accordance with current best practice.</p> <p>(d) Flow velocities within drainage channels and at the entrance and exit of all drainage structures (including chutes, slope drains, and spillways) are controlled in such a manner that prevents soil erosion during all discharges up to the relevant design discharge.</p> |
| P43 | Stormwater movement through the site is appropriately managed to minimise environmental harm. | A43 | <p>(a) All temporary and permanent drainage systems are installed as soon as practicable.</p> <p>(b) "Clean" water is diverted around sediment traps in a manner that maximises the sediment trapping efficiency of the sediment trap.</p> <p>(c) All reasonable and practicable measures are taken to ensure stormwater runoff entering an area of soil disturbance is diverted around or through that area in a manner that minimises soil erosion and contamination of that water for all discharges up to the specified design discharge.</p> <p>(d) Adequate drainage controls (e.g. cross drainage systems and/or longitudinal drainage) are applied to all unsealed roads and tracks to minimise erosion on, and sediment runoff from, such</p> |

| | | | |
|------------|---|------------|---|
| | | | <p>surfaces.</p> <p>(e) All reasonable and practicable measures are taken to ensure sediment-laden runoff from access roads and stabilised entry/exit systems drains to an appropriate sediment control device.</p> <p>(f) All reasonable and practicable measures are taken to divert stormwater around excavations and trenches.</p> |
| P44 | Stormwater movement through the site is appropriately managed to minimise site wetness within active work areas. | A44 | <p>(a) Roof water does not unreasonably increase soil wetness within work areas.</p> <p>(b) Roof water drainage systems are installed prior to placement of the roof.</p> <p>(c) Roof water drainage systems are connected to an approved stormwater drainage system immediately after placement of the roof.</p> |
| P45 | Stormwater entering into, or discharged from, the site is appropriately managed to minimise flooding, damage and nuisance to neighbouring properties. | A45 | <p>(a) All waters discharged during the construction phase are discharged onto stable land, in a non-erosive manner, and at a legal point of discharge.</p> <p>(b) All drainage channels up-slope of neighbouring properties are constructed and maintained with sufficient size, gradient and surface conditions to maintain the required hydraulic capacity.</p> <p>(c) Stormwater is not unlawfully diverted into neighbouring properties.</p> |

| EROSION CONTROL | | | |
|-----------------------------|---|----------------------------|---|
| Performance Criteria | | Acceptable Solution | |
| P46 | Erosion control measures are designed, installed and maintained to an appropriate standard. | A46 | <p>(a) The standard of erosion control complies with the requirements of the relevant regulatory authority, or where such a standard does not exist, erosion controls are designed in accordance with current best practice.</p> <p>(b) As a minimum, the type and degree of erosion control are commensurate with the expected site conditions, soil type, potential environmental risk, and the type, cost, and scope of the works.</p> <p>(c) The adopted erosion control measures remain relevant, at all times, to the current and imminent site conditions.</p> |
| P47 | The control of soil erosion is given appropriate priority. | A47 | <p>(a) Wherever reasonable and practicable, priority is given to the prevention, or at least minimisation, of soil erosion, rather than allowing soil erosion to occur and trying to trap the resulting sediment.</p> <p>(b) The existence of best practice sediment control measures within a given sub-catchment does not diminish the need for the application of best-practice erosion control measures.</p> |
| P48 | Soil erosion is minimised. | A48 | <p>(a) Appropriate erosion control measures are incorporated into all stages of a development, including each phase of earthworks.</p> <p>(b) Site activities are carried out in a manner that minimises the duration that any and all disturbed soil surfaces are exposed to the erosive forces of wind, rain and flowing water.</p> |

| | | | |
|------------|--|------------|--|
| | | | <p>(c) Erosion control measures are applied to exposed soils as soon as practicable after earthworks have been completed within each sub-area.</p> <p>(d) The application of necessary erosion control measures is not unnecessarily delayed for the purpose of coordinating such activities with final site rehabilitation/revegetation.</p> <p>(e) Appropriate drainage and erosion control measures are implemented and maintained around the site office area and on temporary access roads to minimise raindrop impact erosion and the generation of mud.</p> |
| P49 | Soil erosion resulting from rainfall is minimised. | A49 | <p>(a) Soil disturbing activities are programmed to minimise soil exposure during periods when:</p> <p>(i) the monthly rainfall erosivity is expected to exceed 1500, or</p> <p>(ii) the monthly rainfall is expected to exceed 225mm.</p> <p>(b) Existing ground covers are protected from damage and retained as long as practicable.</p> <p>(c) Exposed dispersible soils are either treated or covered with a layer of non-dispersible soil before being covered with vegetation, mulch or erosion control blankets.</p> |
| P50 | Soil erosion resulting from surface water flow is minimised. | A50 | Service trenches are backfilled, compacted and rehabilitated in a manner that prevents undesirable water flow and soil erosion along the trench. |
| P51 | Soil erosion resulting from wind erosion is minimised. | A51 | <p>(a) Erosion control measures used to control wind erosion are commensurate with soil exposure and the expected wind conditions in terms of speed and direction.</p> <p>(b) Stockpiles of erodible material are covered during periods of strong wind or when strong winds are imminent.</p> |

| SEDIMENT CONTROL | | | |
|-----------------------------|--|----------------------------|--|
| Performance Criteria | | Acceptable Solution | |
| P52 | Sediment control measures are designed, installed, operated and maintained to an appropriate standard. | A52 | <p>(a) The standard of sediment control complies with the requirements of the relevant regulatory authority, or where such a standard does not exist, sediment controls are designed in accordance with current best practice.</p> <p>(b) As a minimum, the type and degree of sediment controls are commensurate with the site conditions, soil type, potential environmental risk, and the type, cost, and scope of the works.</p> <p>(c) No sub-catchment relies solely on “supplementary” sediment traps unless site conditions prevent the use of other more appropriate sediment control systems.</p> <p>(d) As-Constructed plans are prepared for all constructed sediment basins and associated emergency spillways.</p> <p>(e) The adopted sediment control measures remain relevant at all times to the current and imminent site conditions.</p> |
| P53 | The on-site retention of sediment is maximised. | A53 | <p>(a) All reasonable and practicable measures are taken to prevent, or at least minimise, the release of sediment from the site, or into water where it is likely to cause environmental harm.</p> <p>(b) Appropriate sediment controls are installed and made operational before any up-slope soil disturbance occurs.</p> <p>(c) All sediment-laden runoff from the site is directed to an appropriate sediment control device in accordance with the required treatment standard.</p> <p>(d) The site’s sediment control standard does not rely on operation of off-site sediment control systems.</p> <p>(e) Optimum benefit is made of every opportunity to trap sediment within the work site.</p> <p>(f) Sediment is trapped as close to its source as possible.</p> <p>(g) Appropriate sediment control measures are applied to all temporary building and construction works, including the site office, car park, stockpile areas and watercourse crossings.</p> <p>(h) Sediment traps are designed, constructed, maintained and operated to collect and <u>retain</u> sediment.</p> <p>(i) All Type F and Type D sediment basins are maintained at a minimum achievable water level between rainfall events.</p> |
| P54 | Sediment displaced off-site by vehicular traffic is minimised. | A54 | <p>(a) Number of site entry/exit points is limited to the minimum practical number.</p> <p>(b) Site entry/exit points are appropriately designed and stabilised to minimise sediment being washed off the site by stormwater and/or being transported off the site by vehicles.</p> |

| | | | |
|------------|---|------------|--|
| | | | (c) All reasonable and practicable measures are taken to ensure sediment-laden stormwater runoff from access roads and stabilised entry/exit systems drains to an appropriate sediment control device. |
| P55 | Sediment-related environmental harm resulting from de-watering activities is minimised. | A55 | <p>(a) Flow diversion barriers, or other appropriate systems, are used to minimise the quantity of watering entering excavations and trenches.</p> <p>(b) All sediment control measures implemented for the control of sediment-laden discharge from de-watering activities are designed to satisfy, as a minimum, current best practice discharge standards.</p> <p>(c) As a minimum, the type and degree of sediment controls utilised during de-watering operations are commensurate with the site conditions, soil type, potential environmental risk, and the type, cost, and scope of the works.</p> |
| P56 | Sediment control measures are located within the property boundary. | A56 | <p>All sediment control measures are located within the property boundary, unless:</p> <p>(i) it is that portion of the entry/exit pad located between the property boundary and the sealed road; or</p> <p>(ii) the sediment control measure is required to collect sediment wash-off from building works located along the property boundary; and</p> <p>(iii) approval has been obtained from the relevant regulatory authority and the relevant landowner or asset manager.</p> |

| SITE STABILISATION AND REHABILITATION | | | |
|--|---|----------------------------|--|
| Performance Criteria | | Acceptable Solution | |
| P57 | Site rehabilitation, including site revegetation, is designed, installed and maintained to an appropriate standard. | A57 | <p>(a) The standard of site rehabilitation complies with the requirements of the relevant regulatory authority or, where such a standard does not exist, complies with current best practice.</p> <p>(b) As a minimum, the type and degree of site rehabilitation is commensurate with the expected site conditions, soil type, potential environmental risk, and the type, cost and scope of the works.</p> <p>(c) Site rehabilitation, including site revegetation, remains, at all times during the construction and specified maintenance period, relevant to the current and imminent site conditions.</p> |
| P58 | Adequate site data is obtained to allow the appropriate design of site rehabilitation measures. | A58 | All necessary site data, including soil data, is obtained to appropriately plan, design, implement and maintain site revegetation and stabilisation. |
| P59 | Site rehabilitation methods and procedures minimise the risk of environmental harm. | A59 | <p>(a) Site revegetation, excluding temporary revegetation conducted for purposes of erosion control, is conducted in accordance with a Site Stabilisation Plan, Landscape Plan, Revegetation Plan, or Vegetation Management Plan, where such a plan exists.</p> <p>(b) Disturbed soil surfaces are appropriately stabilised to minimise the risk of short-term soil erosion.</p> <p>(c) Site stabilisation and/or revegetation are commenced as soon as practicable after earthworks are completed within any given manageable drainage area.</p> <p>(d) The Construction Schedule and/or ESC Installation Sequence clearly indicates the staging of site stabilisation and revegetation measures.</p> <p>(e) All temporary ESC measures are removed and the land rehabilitated as soon as practicable after they are no longer needed.</p> |
| P60 | Optimum soil conditions are achieved prior to revegetation. | A60 | <p>(a) Soil surfaces that are to be vegetated, are left in an appropriate roughened state, and an appropriate physical and chemical condition, to encourage rapid revegetation.</p> <p>(b) Required adjusts to the soil condition are made prior to seeding/planting.</p> |
| P61 | Site rehabilitation methods, procedures, and outcomes are compatible with site conditions and local environmental values. | A61 | <p>(a) The qualifications and experience of the personnel preparing and/or supervising the preparation of any Site Stabilisation Plan, Vegetation Management Plan, or similar, are commensurate with the potential environmental risk, and the extent and complexity of the works.</p> <p>(b) Plant selection and landscape design are compatible with identified environmental values.</p> |

| SITE INSPECTION AND MONITORING | | | |
|---------------------------------------|---|----------------------------|--|
| Performance Criteria | | Acceptable Solution | |
| P62 | A Monitoring and Maintenance Program is prepared by, or under the supervision of, suitably qualified and experienced personnel. | A62 | The qualifications and experience of the personnel preparing and/or supervising the preparation of the Monitoring and Maintenance Program is commensurate with the potential environmental risk, and the extent and complexity of the works. |
| P63 | The performance of the site's drainage, erosion and sediment control measures is regularly monitored. | A63 | <p>(a) The extent and complexity of site monitoring (including water quality monitoring) is commensurate with the potential environmental risk, and the extent and complexity of the works.</p> <p>(b) A record is maintained of the site's compliance and non-compliance with erosion and sediment control approval requirements.</p> <p>(c) All site monitoring data including environmental incidents, rainfall records, dates of water quality testing, testing results, and records of controlled water releases for the site, are kept in an on-site register.</p> |
| P64 | The site's drainage, erosion and sediment control measures remain relevant at all times to the current site conditions. | A64 | <p>All ESC measures are inspected by site personnel:</p> <ul style="list-style-type: none"> (i) at least daily (when work is occurring on-site); (ii) at least weekly (when work is not occurring on-site); (iii) within 24 hours of expected rainfall; and (iv) within 18 hours of a rainfall event of sufficient intensity and duration to cause runoff on the site. |

| SITE MAINTENANCE | | | |
|-----------------------------|--|----------------------------|--|
| Performance Criteria | | Acceptable Solution | |
| P65 | All ESC measures are maintained in proper working order at all times during their required operational life. | A65 | <p>(a) All ESC measures are maintained in proper working order for the duration of the period in which their operation is required in order to satisfy the required treatment standard, and/or the objective of the ESCP.</p> <p>(b) All sediment control measures are maintained in accordance with the requirements of the relevant regulatory authority, or where such a standard does not exist, in accordance with current best practice.</p> <p>(c) As a minimum, the maintenance of all ESC measures is commensurate with the expected site conditions, and potential environmental risk.</p> <p>(d) Suitable access is provided to allow the proper installation and maintenance of sediment traps.</p> <p>(e) The ESCP clearly indicates what degree of site stabilisation is required prior to the decommissioning of any ESC measure.</p> |

| | | | |
|------------|---|------------|--|
| P66 | The maintenance of ESC measures does not increase the risk of soil erosion. | A66 | (a) Excess vegetation cleared for the purpose of restoring the hydraulic capacity of open drains is selectively cut and trimmed so as to leave a short, dense, live ground cover with a grass length no shorter than 50mm. (b) Maintenance mowing is done in a manner that does not damage the profile of formed, soft edges, such as the crest of earth embankments. |
| P67 | The maintenance of ESC measures does not cause environmental harm. | A67 | All materials removed from ESC devices during maintenance or decommissioning, whether solid or liquid, is lawfully disposed of in a manner that does not cause ongoing soil erosion or environmental harm. |

Attachment A (Code of practice)

DEVELOPMENT PLANNING AND DESIGN

The *intent* of the Development Planning and Design section is to:

- enable erosion and sediment control issues to appropriately influence the planning and design of developments and other land disturbing activities for the purpose of minimising their overall adverse environmental impact;
- enable development planners to recognise that along with consideration of the operational phase of a development, appropriate consideration must be given to how something is to be constructed, and the potential adverse impacts of this construction phase.

Acceptable Solution A1(a)

Data collection may include soil testing, identification of potential site constraints, and development of a Conceptual Erosion and Sediment Control Plan (where such data and/or plans are considered reasonably necessary to enable appropriate site planning and design). Appropriate site planning and design refers to the aim of minimising the potential environmental harm (both during the construction and operational phases) of the development. The extent and complexity of data collection is discussed further in Chapter 3 – *Site planning*.

Sufficient soil data must be obtained on the site to:

- (i) reasonable identify the location of dispersive soils;
- (ii) reasonable identify the location of potential acid sulfate soils;
- (iii) allow the appropriate selection, design, and specification of ESC measures;
- (iv) maximise the erosion control benefits of the proposed site revegetation and stabilisation works.

The “potential environmental risk” relates to the potential of a land-disturbing activity to cause harm, whether material, serious, reversible or irreversible, to an environmental value, including nuisance to a neighbouring property or person. The potential environmental risk is related, in part, to the assessed Erosion Hazard (refer to Appendix F – *Erosion hazard assessment*).

Acceptable Solution A1(b)

Potential site constraints are discussed within Chapter 3 – *Site planning*, and include:

- limitations of the supply of water;
- problematic soils and soil conditions, including: acid sulfate soils, dispersive or sodic soils, expansive/reactive soils (cracking clays), soils of extreme pH (less than 5.5 or greater than 8.5), soils of low wet-bearing strength, saline soils, toxic soils, and any other soil that could result in ongoing erosion or environmental harm;
- topographic limitations, including: coastal and intertidal areas, drainage problem areas, existing erosion problems, flood prone land, land prone to mass movement, local microclimates, rock outcrops, steep slope, waterways and wetlands.

Problematic soils are discussed in more detail in Section 3.4 of Chapter 3, and Section C11 of Appendix C – *Soils and revegetation*.

Zones of high or extreme erosion hazard may be identified through the application of an appropriate Erosion Hazard Assessment scheme such as those discussed in Chapter 3 – *Site planning*, and Appendix F – *Erosion hazard assessment*.

Acceptable Solution A1(c)

A Conceptual Erosion and Sediment Control Plan incorporates plan(s) (no larger than 1:1000), that:

- (i) identify the likely need for the construction of *Sediment Basins* on the site;
- (ii) identify that adequate space has been made available for the construction and operation of major sediment traps and essential flow diversion systems;
- (iii) demonstrate that there is a feasible means of constructing the project while still protecting key environmental values;
- (iv) identify problem soil areas including, dispersive soils, acid sulfate soils, and areas of potential mass movement;
- (v) identify key environmental features on the site such as protected vegetation.

The preparation of Erosion and Sediment Control Plans (ESCPs), including Conceptual ESCPs is discussed in Chapter 5 – *Preparation of plans*.

Environmental risk, project cost, and safety issues must be given appropriate consideration when determining the development layout and construction process.

Construction activities that are deemed to represent a high to extreme erosion hazard include:

- Any disturbance of high to extreme hazard areas, or a problematic soil that could result in unmanageable soil erosion and/or environmental harm.
- Any construction or building activity, or procedure, that could potentially cause “serious” environmental harm.
- Any soil disturbance that could cause the transformation of significant quantities of potential acid sulfate soils (PASS) into actual acid sulfate soils (AASS), such as to cause “material” or “serious” environmental harm.

Acceptable Solution A2(b)

The development design must aim to minimise, if not totally avoid, disturbance to high or extreme erosion hazard areas, including dispersive soils, acid sulfate soils, and slopes steeper than 20%, wherever reasonable and practicable.

Acceptable Solution A3(a)

Refer to A1(c) for discussion on “high-risk construction activities”.

Acceptable Solution A3(b)

Essential ESC control measures include any drainage, erosion or sediment control measures that are considered critical in regards the protection of environmental values. Such measures usually include:

- all Type 1 sediment traps, including *Sediment Basins*;
- all Type 2 sediment traps located within sub-catchments that do not incorporate a Type 1 sediment trap;
- all Type 3 sediment traps located within sub-catchments that do not incorporate a Type 1 or Type 2 sediment trap;
- drainage control measures that allow the diversion of up-slope catchment areas in excess of 2500m²;
- any instream sediment control or flow diversion system.

Acceptable Solution A3(c) & (d)

The most critical issue is ensuring sufficient space is available to construct and maintain all *Sediment Basins*, including associated settling ponds, embankments and spillways.

Acceptable Solution A3(e)

If erosion control practices are reliant on final site revegetation, then to the maximum degree practicable, such activities must be allowed to occur in close association with the staging of soil disturbance for the purpose of minimising the duration that any and all soil surfaces are exposed to the erosive force of wind, rain and flowing water.

Acceptable Solution A4(a)

Reference is to drainage design standards suitable for the operational phase of developments, not the drainage standards presented within this document, which focuses on the construction phase.

Acceptable Solution A4(b)

Ongoing erosion problems can result from any of the following:

- changes to the volume, duration, frequency, or rate of stormwater runoff;
- excessive (i.e. erosive) flow velocities;
- inappropriate distribution of flow velocities throughout the depth and width of flow discharged from a stormwater drain into a receiving water;
- inappropriate direction of flow discharged from a stormwater drain into a receiving water.

Acceptable Solution A4(d)

Refer to A1(b) for discussion on “site constraints”.

Acceptable Solution A4(e)

The full impact of the removal of deep-rooted vegetation from steep slopes may not be evident for 5 to 10 years, or until such time as the plant root system begins to fail (assuming that the root system remains within the soil profile after removal of the upper portion of the plant). Planners and designers must appreciate that plants provide many essential roles besides the provision of “scenery”.

Acceptable Solution A5(b)

“Temporary” watercourse crossings referring to those crossings constructed for use only during the construction phase.

CONSTRUCTION PLANNING

The *intent* of the Construction Planning section is to:

- take all reasonable and practicable measures to actively avoid foreseeable soil erosion problems and associated environmental hazards during the construction phase; and
- to ensure that those involved in construction planning do **not** assume that the environmental impact of such hazards can be totally resolved (irrespective of the site’s layout, methodology, staging, and programming) through applying best practice erosion and sediment control.

“Construction planning” refers to planning the layout, methodology, staging, and programming (timing and scheduling) of the construction phase.

Acceptable Solution A6(a)

Refer to A1(b) for discussion on “zones of high and extreme erosion hazard”.

Acceptable Solution A6(b)

Refer to A1(a) for discussion on “potential environmental risk”.

Acceptable Solution A7(a)

Ideally, Erosion and Sediment Control Plans (ESCPs) should be developed in close association with construction planning because the needs and limitations of the construction process represent an important component of the ESCP. In theory, a construction process cannot be finalised without reference to an ESCP, and an ESCP cannot be finalised without knowledge of the construction process.

Acceptable Solution A7(b) & (c)

Refer to A1(c) for discussion on “high-risk construction activities”.

Refer to A1(b) for discussion on “zones of high and extreme erosion hazard”.

Periods of high and extreme erosion potential refers to the variation in the erosion hazard throughout a calendar year based on variations in the rainfall erosivity as described in Appendix E – *Soil loss estimation*. Periods of high to extreme erosion potential include:

- periods of high to extreme erosion risk as defined in Section 4.4 of Chapter 4 – *Design standards and technique selection*; and
- periods of strong winds sufficient to cause significant dust problems.

Acceptable Solution A7(f)

Reference is made to the extent of unnecessary soil disturbance that can be influenced by the construction planning process. The extent of any unnecessary soil disturbance, including disturbances outside the designated work area, must be minimised in order to minimise the risk of environmental harm.

Minimising the potential environmental harm can be achieved, in part, by scheduling major land disturbances, and disturbances to high and extreme erosion risk areas, for the least erosive periods of the year.

Acceptable Solution A7(g)

Site Stabilisation Plans, Landscape Plans, and/or Vegetation Management Plans must show progressive stabilisation of exposed soil for the purposes of erosion control, including but not limited to, all of the following:

- (i) schedule for stabilisation of exposed soil areas; and
- (ii) specifications for subsoil and topsoil preparation and application; and
- (iii) specification of stabilisation by mulching or other appropriate surface treatment (note, grass seeding without adequate mulching is generally not considered best-practice); and
- (iv) details on the type and application rate of any tackifiers to be used in the application of mulches (including hydromulch, Bonded Fibre Matrix, and Compost Blankets).

Water Quality Monitoring Programs must document proposed water quality monitoring, and include:

- location of all instream water quality monitoring stations;
- water quality monitoring, sampling, and analysis procedures and standards.

EROSION AND SEDIMENT CONTROL PLAN (ESCP)

The *intent* of this section is to ensure Erosion and Sediment Control Plans (ESCPs):

- are appropriate for the site conditions, which may vary from time to time;
- are prepared by, or under the supervision of, suitable personnel;
- are able to achieve the required design standard and environmental protection.

Acceptable Solution A9(a)

Such a clause shall not reduce the responsibility of applying and maintaining, at all times, all necessary sediment control measures in accordance with the sediment control standard.

Acceptable Solution A9(b)

Refer to A1(a) for discussion on “environmental risk”.

It is recognised that the degree of erosion and sediment control is related to the type, cost and scope of works in addition to the environmental risk. This association is acknowledged within the terms of current best practice erosion and sediment control as defined within this document (2008 conditions).

Acceptable Solution A9(c)

On very minor works, such as regular council maintenance activities, or the installation of minor services, the ESCP may be represented by standard drawings prepared by the principle company/organisation as part of an in-house Code of Practice. The key *intent* is to ensure that appropriate consideration is given to erosion and sediment control requirements **before** works commence.

On sites with a soil disturbance greater than 2500m², the Erosion and Sediment Control Plan (including supporting documentation and construction specifications) must include:

- (i) North point and plan scale.
- (ii) Site and easement boundaries and adjoining roadways.
- (iii) Construction access points.
- (iv) Site office, car park and location of stockpiles.
- (v) Proposed construction activities and limits of disturbance.
- (vi) Retained vegetation including protected trees.
- (vii) General soil information and location of problem soils.
- (viii) Location of critical environmental values (where appropriate).
- (ix) Existing site contours (unless the provision of these contours adversely impacts the clarity of the ESCP).
- (x) Final site contours including locations of cut and fill.
- (xi) Construction Drainage Plans for each stage of earthworks, including land contours for that stage of construction, sub-catchment boundaries and location of watercourses.
- (xii) General layout and staging of proposed works.
- (xiii) Location of all drainage, erosion and sediment control measures.
- (xiv) Full design and construction details (e.g. cross-sections, minimum channel grades, channel linings,) for all drainage and sediment control devices, including Diversion Channels and Sediment Basins.
- (xv) Construction specifications for adopted ESC measures (as appropriate).
- (xvi) Site revegetation requirements (if not contained within separate plans).
- (xvii) Site Monitoring and Maintenance Program, including the location of proposed water quality monitoring stations.
- (xviii) Technical notes relating to:

- site preparation and land clearing;
 - extent, timing and application of erosion control measures;
 - temporary ESC measures installed at end of working day;
 - temporary ESC measure in case of impending storms, or emergency situations;
 - installation sequence for ESC measures;
 - site revegetation and rehabilitation requirements;
 - application rates (or at least the minimum application rates) for mulching and revegetation measures;
 - legend of standard symbols used within the plans.
- (xix) Calculation sheets for the sizing of ESC measures.
- (xx) A completed Erosion and Sediment Control Plan checklist such as presented in *[insert publication]*.
- (xxi) Any other relevant information the regulatory authority may require to properly assess the ESCP.

Site-specific ESCPs must address all aspects of proposed site disturbance, temporary drainage works, erosion and sediment control measures, installation sequence, and site rehabilitation for the duration of the construction phase, including (where appropriate) the nominated maintenance period.

If the timing of the proposed construction activity is not known during development of the ESCP, and if rainfall erosivity varies significantly throughout the year, then the erosion control specifications placed on the ESCP must specify appropriate erosion control measures for each level of rainfall erosivity. For example, light mulching may be appropriate during periods of light rainfall, hydromulching during periods of light to moderate rainfall, and *Erosion Control Blankets* or *Bonded Fibre Matrix* during those periods of the year when moderate to heavy rainfall is either occurring or expected to occur.

The ESCP must clearly state that no land-disturbing activities shall occur on the site until all associated perimeter ESC measures, including *Sediment Basins* and temporary drainage controls, have been constructed in accordance with the ESCP and best practice erosion and sediment control procedures.

Sufficient information and detail includes the provision of sufficient long-sections and cross-section of all Type 1 and Type 2 sediment traps (e.g. *Sediment Basins*) relative to existing and/or final ground levels to allow their construction.

On sites with a soil disturbance greater than one (1) hectare, the Erosion and Sediment Control Plan must include:

- Individual ESCPs for: the “bulk earthworks” phase, “roadworks and drainage” phase and the “practical completion/on-maintenance” phases of construction. Each phase above must be documented graphically on a dedicated ESCP, or Detail shown on an ESCP, and supported by a clearly documented construction sequence, or ESC installation sequence, which describes the timing of key ESC actions on the site.
- Procedures for the temporary shutdown of the site, whether a planned or unplanned shutdown.

Acceptable Solution A10(b) & (c)

A suitably qualified and experienced professional is defined as a person with:

- (i) training and/or qualifications in erosion and sediment control that are recognised by the regulatory authority; and
- (ii) professional affiliations with an engineering, environmental engineering, soil science, and/or scientific organisation (e.g. the International Erosion Control Association; Engineers Australia; Environment Institute of Australia and New Zealand; or the Australian Society of Soil Science Inc.); and
- (iii) at least 2 years experience in the management of erosion and sediment control which can be verified by an independent third party.

ESCPs for high-risk sites should be reviewed by a suitably qualified and experienced third party reviewer prior to its implementation.

The assessment and categorisation of high-risk sites may be defined by the relevant regulatory authority; otherwise, refer to the discussion in Chapter 3 – *Site planning*, and Appendix F – *Erosion hazard assessment*.

Acceptable Solution A10(d)

The *intent* is to ensure the adoption of an appropriate design discharge for sizing the basin and associated emergency spillway, and to ensure the appropriate hydraulic design of the basin's, including the spillway's location, sizing and scour protection.

Acceptable Solution A10(e)

The *intent* is to ensure the appropriate design and construction specification of the embankment with regard to its structural stability.

Acceptable Solution A11(a)

It is sufficient for the extent and complexity of data collection to be determined by a suitably qualified and experienced professional as defined in A10(c) above.

On sites with a soil disturbance greater than one (1) hectare, the site needs to be assessed from a hydrological, hydraulic, vegetation, soils, and geological perspective to determine relevant site constraints that may affect the focus or detail of the ESCP.

Acceptable Solution A11(b)

Typically the drainage standard is based on a specified design storm average recurrence interval (ARI), the erosion standard is based on the expected rainfall erosivity, and the sediment control standard is based on the expected soil loss rate. Refer to Chapter 4 – *Design standards and technique selection* for selection of design standards.

Acceptable Solution A11(c)

On disturbances exceeding 2500m², Construction Drainage Plans need to be prepared for each stage of earth works.

The *intent* of Construction Drainage Plans is to show:

- flow entry and exit points;
- areas of sheet flow and path lines of concentrated flow;
- sub-catchment boundaries;
- all permanent and temporary roads;
- all temporary and permanent drainage control measures expected to exist during the given stage of works.

Acceptable Solution A12(a)

The timing and degree of ESC specified in the Erosion and Sediment Control Plan(s) needs to be appropriate for the given soil properties, expected weather conditions, and susceptibility of the receiving waters to environmental harm resulting from sediment-laden runoff. Current (2008) best practice design standard of the drainage, erosion and sediment control measures are outlined in Chapter 4 – *Design standards and technique selection*.

Acceptable Solution A12(b)

Additional and/or alternative erosion and sediment control measures must be implemented, and a revised Erosion and Sediment Control Plan (ESCP) must be prepared and submitted to relevant regulatory authority for approval (where required) in the event that:

- (i) site conditions significantly change from those previously anticipated; or
- (ii) there is a high probability that serious or material environmental harm might occur as a result of sediment leaving the site; or
- (iii) the implemented works fail to achieve the adopted ESC standard, or the State's environmental protection requirements; or
- (iv) site inspections indicate that the implemented works are failing to achieve the "objective" of this ESCP.

Acceptable Solution A12(d)

A suitably qualified and experienced professional is defined in A10(c) above.

Acceptable Solution A13

Synthetic reinforced fabrics include “plastic” reinforced Erosion Control Blankets, Mats and Meshes.

SITE ESTABLISHMENT

The *intent* of this section is to ensure that during site establishment:

- on-site personnel are provided with all necessary information to fully comply with all legal requirements, minimise environmental harm, and achieve the objective of the ESCP; and
- land-disturbing activities proceed in a manner consistent with the objective of the ESCP.

Acceptable Solution A14(a)

Supply of such material is relevant only to that material that exists, or is required to exist.

Acceptable Solution A14(b)

A discussion on site shutdown procedures is provided in Section 6.15 of Chapter 6 – *Site management*.

Acceptable Solution A15(a)

On low-risk sites, ESC audits (including site inspections and water quality monitoring) may be performed by site personnel; however, as the risk of environmental harm increases, the need for third-party site inspections and water quality monitoring increases.

Personnel undertaking ESC audits of a site must, collectively, have the following capabilities:

- (i) an understanding of the local environmental values that could potentially be affected by the proposed works; and
- (ii) a good working knowledge of the site’s Erosion and Sediment Control (ESC) issues, and potential environmental impacts, that is commensurate with the complexity of the site and the degree of environmental risk; and
- (iii) a good working knowledge of current best practice Erosion and Sediment Control measures for the given site conditions and type of works; and
- (iv) ability to appropriately monitor, interpret, and report on the site’s ESC performance, including the ability to recognise poor performance and potential ESC problems; and
- (v) ability to provide advice and guidance on appropriate measures and procedures to maintain the site at all times in a condition representative of current best practice, and that is reasonably likely to achieve the required ESC standard; and
- (vi) a good working knowledge of the correct installation, operational and maintenance procedures for the full range of ESC measures used on the site.

Acceptable Solution A15(b)

The construction industry’s dealing of *Work Place Safety* issues provides a good model for the development of an appropriate “Chain of Command” for the protection of environmental values. The aim is to produce a fair, reasonable and practicable approach based on environmental risk.

As in workplace safety, the responsibility of environmental protection, and therefore erosion and sediment control, rests with **all** site personnel, whether or not the work site is the normal place of work of any and all personnel. Establishing a “chain of command” does **not** diminish the responsibility of each and every person to take all reasonable and practicable measures to minimise environmental harm resulting from their actions as per their “environmental duty of care”.

Acceptable Solution A16(a)

The exception to this clause is land disturbance necessary to provide access and allow the installation the initial ESC measures.

In general, initial land-disturbing activities should be limited to the establishment of the site compound, site entry/exit points, temporary drainage controls (including drain stabilisation measures), haul road(s), perimeter sediment controls, and any *Sediment Basins/traps* required for the first stage of works.

Acceptable Solution A16(b)

“Operational activities” include such things as material stockpiles, storage areas, vehicle maintenance facilities, cleaning stations and concrete waste receptors.

Acceptable Solution A16(c)

“Waste collection areas include litter bins and receptors for waste concrete.

Acceptable Solution A17(b)

Within the limits of what is considered reasonable and practicable, site managers should take appropriate actions (such as fencing) to minimise the potential environmental harm cause by both authorised and unauthorised access onto the site.

Acceptable Solution A17(c)

It is recognised that it may not be practicable for **all** stormwater runoff from **all** areas of site entry/exit paths to be directed to a sediment trap; however, such areas must be limited to the minimum practicable.

SITE MANAGEMENT**Acceptable Solution A18(a)**

Where appropriate, an Erosion and Sediment Control Plan is prepared (in accordance with Section G3.3), and where necessary approved by a relevant regulatory authority, prior to commencing any land-disturbing activities.

Acceptable Solution A18(b)

The potential for environmental harm must be assessed by a recognised expert or authority.

Acceptable Solution A18(c)

Refer to A1(a) for discussion on “potential environmental risk”.

Acceptable Solution A18(d)

Applies to all land-disturbing activities, whether planned or unplanned, and especially to any works that are required to be conducted without an associated Erosion and Sediment Control Plan.

Acceptable Solution A18(d)(iv)

Includes ensuring that the value and use of land/properties adjacent to the development (including roads) are not diminished as a result of work-related soil erosion and sediment runoff.

Acceptable Solution A19

“Responsible ESC personnel” are those persons employed or contracted by the land owner and/or developer as the principal officer(s) responsible for ensuring appropriate application of the planned ESC measures and for the provision of advice in response to unplanned ESC issues.

Acceptable Solution A20(a)

Recommended training requirements are discussed in Section 6.19 of Chapter 6 – *Site management*.

Acceptable Solution A20(b)

Necessary disturbance to ESC measures would include the short-term removal of an ESC measure to allow the installation of services under the ESC measure, or to allow vehicular or material access.

Performance Criterion P21

Performance Criteria P21 and P22 require work sites to be appropriately prepared for both current and imminent site conditions. Compliance with these criteria requires ESCPs to be living documents that remain both effective and flexible, and thus are able to appropriately adapt to changing site conditions.

Acceptable Solution A21(b)

A significant change in site conditions includes:

- unseasonable weather conditions;
- exposure of problematic soil conditions not previously anticipated;
- significant change in construction methodology, staging or programming of earthworks and/or site stabilisation activities;
- significant change in the development design or layout;
- an unprogrammed site shutdown.

Performance Criterion P22

Performance Criteria P21 and P22 require work sites to be appropriately prepared for both current and imminent site conditions. Compliance with these criteria requires ESCPs to be living documents that remain both effective and flexible, and thus are able to appropriately adapt to changing site conditions.

Acceptable Solution A24(a)

Appropriate identification depends on the level of risk of damage to protected or retained vegetation. Appropriate identification does not necessarily mean markers, signs or fencing; however, such measures may be appropriate in some areas.

Acceptable Solution A25(b)

AS1940 *The storage and handling of flammable and combustible liquids* (as amended from time to time).

In addition to the above:

- Impervious bunds must be constructed around all storage areas containing more than 1m³ of petroleum and oil-based products such that the enclosed volume is large enough to contain 110% of the volume held in the largest, individual storage tank.
- On-site personnel involved in the handling and storage of flammable and combustible liquids, including all liquid chemicals, must be appropriately trained and/or supervised, as required in order to allow such personnel to appropriately preform such activities.

Acceptable Solution A25(c)

Current (2008) best practice requires that all reasonable and practicable measures are taken to:

- (i) prevent the release of cement-laden runoff, concrete waste, and chemical products (including petroleum and oil-based products), into an internal or external water body, completed internal drainage systems, or any external drainage system, excluding those on-site drains and water bodies specifically designed to contain and/or treat such material;
- (ii) ensure all solid and liquid waste from concrete production, and concreting equipment (including delivery and placement vehicles), is fully contained within the property;
- (iii) ensure cement residue from work activities is:
 - retained on a pervious surface (e.g. a grassed or open soil area, or excavated trench); or
 - filtered through a fine-grained, porous earth embankment; or
 - collected and disposed of in a manner that minimises ongoing environmental harm.

Acceptable Solution A25(d)

Current (2008) best practice requires that wherever practicable, the cutting of bricks, concrete, ceramics, and other slurry-producing materials must be carried out in a manner that:

- (i) complies with current State guidelines, policies, and legislation; and
- (ii) fully contains any contaminated waste water for later treatment and/or lawful disposal; or
- (iii) appropriately filters (e.g. through a fine-grained, porous earth embankment) any contaminated slurry/water prior to its release from the immediate work area.

Acceptable Solution A25(e)

Current (2008) best practice requires that wherever practicable, the washing of tools and painting equipment is carried out in a manner that:

- (i) complies with current State guidelines, policies and legislation; and
- (ii) fully contains any contaminated waste water for later treatment and/or lawful disposal; or
- (iii) appropriately filters (e.g. through a fine-grained, porous, earth embankment) any contaminated liquid prior to its release from the immediate work area; or

- (iv) appropriately infiltrates all contaminated liquid matter into an area of porous grass or open soil.

Acceptable Solution A26(b)

Sediment and sediment-laden runoff must not settle or collect on public roadways where such material could result in a traffic or safety hazard.

Acceptable Solution A27(a)

“Sediment and other material” includes clay, silt, sand, gravel, soil, mud, cement and fine-ceramic waste.

Acceptable Solution A27(b)

Sealed surfaces include sealed roads and car parks.

In circumstances where the washing/flushing of sealed surfaces is required, all reasonable and practicable sediment control measures must be employed to prevent, or at least minimise, the release of sediment into receiving waters. Only those measures that will not cause safety issues or adverse property flooding to third parties shall be employed.

Acceptable Solution A28(a)

“Appropriate consideration” includes taking all reasonable and practicable measures to minimise safety risks. As a general rule, safety issues take a higher priority than ESC issues; however, this does **not** mean that the existence of potential safety issues diminishes the ESC standard required of a work site.

Public safety risks include potential damage to public vehicles resulting from the use of inappropriate kerb-inlet sediment traps on public roads. The potential safety risk of a proposed sediment trap to site workers and the public must be given appropriate consideration **before** its installation, especially those sediment traps located within publicly accessible areas.

Performance Criterion P29

The protection of wildlife does not diminish the required ESC standard, or the need to take all reasonable and practicable measures to minimise environmental harm resulting from soil erosion and displaced sediment.

Performance Criterion P30

Further discussion on the protection of waterways and the conducting of instream works is provided in Appendix I – *Instream works*.

Performance Criterion P31

A discussion on site shutdown procedures is provided in Section 6.15 of Chapter 6 – *Site management*.

LAND CLEARING**Acceptable Solution A32(c)**

Operational restrictions on the extent and duration of land disturbance, including land clearing (as presented by Performance Criteria P32 to P35), only apply when such land disturbance is at risk, or potentially at risk, of erosion by wind, rain, or flowing water.

The potential erosion risk is related (in part) to the potential rainfall erosivity as defined in Section 4.4 of Chapter 4 – *Design standards and technique selection*. The potential erosion hazard may be identified through the application of an appropriate Erosion Hazard Assessment scheme such as those discussed in Chapter 3 – *Site planning*, and Appendix F – *Erosion hazard assessment*.

Acceptable Solution A33(b)

The extent of unnecessary soil disturbance, including disturbances outside the designated work area, must be minimised at all times.

Wherever reasonable and practicable, land clearing must be limited to the current stage of works. Current (2008) best practice recommends that land clearing not extend beyond the

parameters indicated in Table 4.4.7 of Chapter 4 – *Design standards and technique selection*; that being the minimum necessary to provide:

- (i) up to eight (8) weeks of site activity during those months when the expected rainfall erosivity is less than 100, six (6) if between 100 and 285, four (4) weeks if between 285 and 1500, and two (2) weeks if greater than 1500; or
- (ii) up to eight (8) weeks of site activity during those months when the actual or average rainfall is less than 45mm, six (6) if between 45 and 100mm, four (4) weeks if between 100 and 225mm, and two (2) weeks if greater than 22mm.

Condition (ii) generally only applies if directed by the relevant regulatory authority.

Acceptable Solution A33(c)

Clause A33(c) does not imply that land clearing should occur to the full extent of these limits, rather that all reasonable and practicable measures are taken to limit land clearing to no more than these limits. In all cases, land clearing must be limited to the minimum necessary to complete the approved works.

Acceptable Solution A34(c)

During such tree clearing, all reasonable and practicable measures must be taken to minimise unnecessary removal of, or disturbance to, any existing ground cover (organic or inorganic) until just prior to final grubbing and topsoil removal.

In some cases it might be advantageous to perform bulk removal of trees and shrubs at the beginning of each stage of works, followed by the establishment of a temporary grass, mulch or other ground cover. Final grubbing of roots and topsoil removal should then be delayed until just prior to commencement of bulk earthworks.

Acceptable Solution A35(a)

This clause excludes that (minimal) land clearing required for the purpose of installing such ESC measures, in which case only that land clearing required to install such measures shall occur prior to their installation and operation.

SOIL AND STOCKPILE MANAGEMENT

Acceptable Solution A36

Topsoil should be stripped only while in a moist condition. If the soil is too dry it will pulverise the soil, if too wet it may lead to clodding or hardsetting—particularly if the soil has a high silt or clay content. The soil should be wet enough to form a clump when squeezed, but not wet enough to squeeze-out water. Further discussion on the management of soils is provided in Section 6.11 of Chapter 6 – *Site management*.

Performance Criterion A37

Applies to all areas of proposed soil disturbance, including footprint of proposed stockpiles prior to placement of soil within such areas. Does not include any material best described as subsoil.

Acceptable Solution A37(b)

Current (2008) best practice recommendations for the management of topsoil are presented in Table 6.2 in Chapter 6 – *Site management*.

Acceptable Solution A38(ii)

The diversion of up-slope stormwater is recommended during those periods when rainfall is possible and the up-slope catchment area exceeds 1500m².

Current (2008) best practice recommendations for the protection of sand and soil stockpiles from the erosive effects of wind and rainfall are presented in Table 4.6.1 in Chapter 4 – *Design standards and technique selection*.

Acceptable Solution A38(iv)

Current (2008) best practice recommendations for the selection of an appropriate sediment control system is presented in Table 4.6.2 in Chapter 4 – *Design standards and technique selection*.

Short-term stockpiles of erodible material located outside of an appropriate sediment control zone must be covered if it is raining, or if rain is imminent or possible.

Acceptable Solution A39

Dispersive soils normally need to be stabilised (i.e. treated with gypsum or lime depending on desired pH adjustment) and/or buried under a layer of non-dispersive soil prior to placement of channel lining (whether rock, gabion, synthetic material, or concrete), or initiation of revegetation.

Refer to Section 6.12 in Chapter 6 – *Site management*, or Section C11 in Appendix C – *Soils and revegetation* for further discussion on the management of dispersive soils.

Acceptable Solution A40

Refer to Section 6.12 in Chapter 6 – *Site management*, or Section C11 in Appendix C – *Soils and revegetation* for further discussion on the management of acid sulfate soils.

Within Queensland, guidelines on the management of acid sulfate soils is provided in State Planning Policy 2/02 *Guideline: Planning and Managing Development involving Acid Sulfate Soils*, and Dear, et al. 2002, *Queensland Acid Sulfate Soil Technical Manual – Soil Management Guidelines*. Department of Natural Resources and Mines, Indooroopilly, Queensland.

DRAINAGE CONTROL

The *intent* of this section is to take all reasonable and practicable measures to prevent, or at least minimise, environmental harm and public nuisance resulting from the exposure of soil to the erosive forces of flowing water. It is not the intent to unfairly burden those performing land-disturbing activities with the cost and inconvenience of installing and maintaining drainage control measures if there is no risk of such environmental harm and public nuisance.

Acceptable Solution A41(a)

Current (2008) best practice construction phase drainage standards are presented in Table 4.3.1 of Chapter 4 – *Design standards and technique selection*. Drainage systems must be designed to have a minimum non-erosive hydraulic capacity (excluding 150mm freeboard) in accordance with this table.

Acceptable Solution A41(b)

Construction Drainage Plans are normally prepared for sites with a soil disturbance exceeding 2500m². Further discussion on the requirements of *Construction Drainage Plans* is presented in Acceptable Solution A11(d).

Acceptable Solution A41(d)

This clause requires compliance with Performance Criteria P21 and P22.

Acceptable Solution A42(b)

Sandbag flow diversion banks, catch drains, and flow diversion banks are examples of appropriate drainage systems that can be used to divert stormwater around excavations and other soil disturbances.

Acceptable Solution A42(c)

Current (2008) best practice for the lateral spacing of drainage channels down open soil (non vegetated) slopes is presented in Table 4.3.2 of Chapter 4 – *Design standards and technique selection*.

Acceptable Solution A42(d)

The relevant design discharge is related to Acceptable Solution A41(a). The “design flow” or “design discharge” is the design hydraulic capacity of that component of the drainage system.

All temporary and permanent drainage systems must be able to accept the design flow within 10 days of construction. This may require the application of an appropriate permanent or temporary channel liner, or the use of velocity control *Check Dams*.

Acceptable Solution A43(a)

“Temporary” drainage systems are only utilised during the construction phase, and only until the permanent drainage systems are constructed and made operational.

The *intent* of installing the permanent drainage system as soon as practicable is to maximise the effective passage of “clean” water through the site without the risk of contamination by on-site sediment.

Acceptable Solution A43(b)

“Clean” water is defined as water that either enters the property from an external source and has not been further contaminated by sediment within the property; or water that has originated from the site and is of such quality that it either does not need to be treated in order to achieve the required water quality standard, or would not be further improved if it was to pass through the type of sediment trap specified for the site.

Acceptable Solution A43(f)

Does not refer to excavations and trenches that form or act as sediment traps.

Performance Criterion P44

“Active work areas” includes site office and car park areas.

Acceptable Solution A44(a)

The *intent* is to minimise soil erosion and sediment runoff, and on-site safety issues, by reducing the generation of mud within active work areas.

The roof water drainage system needs to be installed before the roof covering is laid. Appropriate roof water drainage systems may be formed from either temporary (i.e. temporary solid or flexible) downpipe, or the permanent drainage system.

Acceptable Solution A44(c)

Does not apply to contaminated (e.g. sediment-laden) roof water.

EROSION CONTROL

The *intent* of this section is to take all reasonable and practicable measures to prevent, or at least minimise, environmental harm and public nuisance resulting from the exposure of soil, sand, silt, mud or cement to the erosive forces of wind, rain and flowing water. It is not the intent to unfairly burden those performing land-disturbing activities with the cost and inconvenience of installing and maintaining erosion control measures if there is no risk of such environmental harm and public nuisance.

Acceptable Solution A46(a)

Current (2008) best practice (construction phase) land clearing and site rehabilitation standards are presented in Table 4.4.7 of Chapter 4 – *Design standards and technique selection*. Unless otherwise stated by the relevant regulatory authority, the potential erosion risk is based on the rating outlined in Table 4.4.1 of Chapter 4 – *Design standards and technique selection*.

In addition, all temporary earth banks, flow diversion systems, and sediment basin embankments should be machine-compacted, seeded and mulched within ten (10) days of formation for the purpose of establishing a vegetative cover, unless otherwise stated within an approved Site Stabilisation Plan, Revegetation Plan, or Vegetation Management Plan.

Acceptable Solution A46(b)

Erosion control measures primarily focus on the control of fine sediments such as clay and silt-sized particles. Thus, with respect to the value of “erosion control measures”, potential environmental harm is strongly related to the susceptibility of the receiving waters to environmental harm resulting from turbid runoff (i.e. suspended fine sediments).

Erosion control measures need to be appropriate for the land slope and the expected wind, rain and hydraulic conditions. Application of effective drainage control measures should help to control hydraulic conditions such that damage to adopted erosion control measures during regular rainfall events is minimised.

Acceptable Solution A46(c)

This clause requires compliance with Performance Criteria P21 and P22.

Acceptable Solution A47(a)

Such a clause shall not reduce the responsibility to apply and maintain, at all times, all necessary sediment control measures.

The minimisation of soil erosion requires the application of effective drainage and erosion control throughout each and all sub-catchments.

Acceptable Solution A48(b)

Compliance with this clause requires:

- soil disturbance within any sub-catchment to be delayed as long as possible, and ideally, not until the principal on-site activities within that area are ready to commence;
- soil disturbance at any given time to be limited to the minimum necessary to perform the required works;
- the extent of unnecessary soil disturbance, including disturbances outside the designated work area, to be minimised.

Disturbed soils associated with non-completed earthworks that are likely to be exposed to rainfall are protected from soil erosion:

- (i) if further soil disturbances are likely to be delayed for more than 30 days during those months when the expected rainfall erosivity is less than 100, or 20 days if between 100 and 285, or 10 days if between 285 and 1500, or 5 days if greater than 1500; or
- (ii) where directed by the regulatory authority, further soil disturbances are likely to be delayed for more than 30 days during those months when the expected rainfall is less than 45mm, or 20 days if between 45 and 100mm, or 10 days if between 100 and 225mm, or 5 days if greater than 225mm.

Acceptable Solution A48(c)

Compliance with the requirements outlined within Table 4.4.7 of Chapter 4 – *Design standards and technique selection* does not diminish the need to apply all reasonable erosion control measures as soon as practicable.

A “sub-area” is an area within a given sub-catchment fully contained within a set of drainage control structures designed to minimise the risk of rill erosion within that area.

Acceptable Solution A48(d)

If the adopted erosion control measures incorporate temporary or permanent grassing, then the application of that grass cover must not be unnecessarily delayed simply because it is (inappropriately) viewed by the principal contractor as part of site revegetation that has been subcontracted to another contractor. In cases where it is not possible for the principal contractor to apply a temporary grass cover (for the purposes of erosion control), then alternative erosion control measures must be applied to protect the site during the intervening period.

Acceptable Solution A49(a)

Condition (ii) generally only applies if directed by the relevant regulatory authority.

Acceptable Solution A49(b)

Existing ground covers include mulch (organic or inorganic), grasses, and other low-growing plants. This clause required compliance with Performance Criterion P34.

Acceptable Solution A49(c)

Dispersive soils normally need to be stabilised (i.e. treated with gypsum or lime depending on desired pH adjustment) and/or buried under a layer of non-dispersive soil prior to placement of channel lining (whether rock, gabion, synthetic material, or concrete), or initiation of revegetation.

Refer to Section 6.12 in Chapter 6 – *Site management*, or Section C11 in Appendix C – *Soils and revegetation* for further discussion on the management of dispersive soils.

Acceptable Solution A50

All stormwater, sewer line and other service trenches not in streets are mulched and seeded, or otherwise appropriately stabilised, within 7 days after backfill, or otherwise rehabilitated in accordance with an approved Site Stabilisation Plan, Landscape Plan, Revegetation Plan, or Vegetation Management Plan.

Acceptable Solution A51(b)

This clause requires compliance with Performance Criterion P38.

SEDIMENT CONTROL

The *intent* of this section is to take all reasonable and practicable measures to prevent, or at least minimise, environmental harm and public nuisance resulting from the exposure, placement, or displacement of sediment (including soil, sand, silt, mud and cement). It is not the intent to unfairly burden those performing land-disturbing activities with the cost and inconvenience of installing and maintaining sediment control measures if there is no risk of such environmental harm and public nuisance.

Acceptable Solution A52(a)

Current (2008) best practice (construction phase) sediment control standards are presented in Table 4.5.1 of Chapter 4 – *Design standards and technique selection*.

Acceptable Solution A52(b)

Relevant site conditions include the soil type, design flow rate, flow condition (i.e. sheet flow or concentrated flow), and erosion hazard. The erosion hazard may be related to the expected soil loss rate (as presented in Table 4.5.1 of Chapter 4, and Appendix E – *Soil loss estimation*), or other factors such as discussed in Appendix F – *Erosion hazard assessment*.

Unless otherwise noted within this document, or specified by the regulatory authority, the design storm for sediment traps (excluding de-watering and instream sediment control measures) must be taken as 0.5 times the 1 in 1 year ARI peak discharge.

The “potential environmental risk” is discussed in Acceptable Solution A1(a), and is summarised in Table 5.1 of Chapter 5 – *Preparation of plans*.

Acceptable Solution A52(c)

A “supplementary” sediment trap is a minor sediment trap, such as *Grass Filter Strips* and most kerb inlet sediment traps, that is not effective enough to be classified as Type 3 sediment trap. Refer to Table 4.5.4 of Chapter 4 – *Design standards and technique selection*.

Acceptable Solution A52(d)

Such plans must appropriately verify the basin’s dimensions, surface level elevation, and surface area (Type C basins) and/or volumes (Type F and Type D basins) comply with the approved design drawings.

Acceptable Solution A53(a)

Compliance with this clause means that no sediment control system is utilised if another more appropriate system (of equivalent treatment standard, i.e. Type 1, 2 or 3) is available. This means that straw bale sediment traps (appropriately wrapped in filter cloth) must not be used unless site conditions prevent the use of any other more appropriate sediment control systems.

Acceptable Solution A53(b)

This means that the catchment area of a *Sediment Basin* is not grubbed of vegetation, or stripped of topsoil, until the basin is fully constructed and operational.

Acceptable Solution A53(d)

This means that sediment control within a development site does not rely on the operation of an off-site sediment trap such as a downstream, council-operated, gross pollutant trap, or other stormwater treatment system.

Acceptable Solution A53(e)

This means that independent of the required sediment control standard within a given sub-catchment, the following actions are taken:

- all reasonable and practicable measures are taken to utilise additional sediment traps of an equivalent or lower efficiency (including “supplementary” sediment traps) throughout the sub-catchment;
- every reasonable and practicable opportunity is taken to trap sediment as close to its source as possible.

Acceptable Solution A53(f)

This does **not** mean that sediment traps should be placed in inappropriate locations; an inappropriate location being one where existence of the sediment trap would likely result in the hydraulic failure of the sediment trap, or unacceptable soil erosion during moderate to heavy rainfall.

Acceptable Solution A53(h)

This clause means that sediment traps are **not** designed to simply divert sediment and sediment-laden waters away from stormwater inlets.

Compliance with this clause includes the following actions:

- (i) Wherever practical, *Sediment Fences* are located along the contour to maintain “sheet” flow conditions down-slope of each fence. Where this is not practical, regular returns are utilised to allow water to pond at regular intervals along the length of the fence.
- (ii) Adopted roadside kerb inlet sediment traps are appropriate for the type of inlet (i.e. sag or on-grade), for further discussion refer to Principle 8.14 in Chapter 2 – *Principles of erosion and sediment control*.

Acceptable Solution A55(a)

The *intent* of this clause is to minimise the quantity of water that needs to be de-watered from excavations and trenches. Thus, if water does not need to be de-watered from such areas, then the clause does not apply.

Acceptable Solution A55(b)

Current (2008) best practice sediment control standards for de-watering activities are outlined in Table 4.5.13 of Chapter 4 – *Design standards and technique selection*.

Alternatively, Table 4.5.14 of Chapter 4 presents a water quality standard for de-watering operations based on Nephelometric Turbidity Units (NTU).

Appropriate sediment controls placed down-slope of material stockpiles during the de-watering of such stockpiles are summarised in Table 4.5.14 of Chapter 4 – *Design standards and technique selection*.

Acceptable Solution A55(c)

The “potential environmental risk” is discussed in Acceptable Solution A1(a), and is summarised in Table 5.1 of Chapter 5 – *Preparation of plans*.

SITE STABILISATION AND REHABILITATION**Acceptable Solution A57(a)**

Current (2008) best-practice site rehabilitation standards are presented in Table 4.4.7 of Chapter 4 – *Design standards and technique selection*. Unless otherwise stated by the relevant regulatory authority, the potential erosion risk shall be based on the rating outlined in Table 4.4.1 of Chapter 4.

Acceptable Solution A58

Data collection necessary to assist the design of site revegetation is outlined in Sections C3 and C9 of Appendix C – *Soils and revegetation*.

Acceptable Solution A59(a)

Temporary revegetation conducted for the purpose of erosion control must be conducted in accordance with a Site Stabilisation Plan, Landscape Plan, Revegetation Plan, or Vegetation Management Plan, where such a plan specifically refers to such activities.

Acceptable Solution A59(b)

The type of permanent vegetation applied to completed earthworks must be compatible with the anticipated long-term land use, current and ongoing erosion risk, environmental requirements (including weed control), and associated components of the site rehabilitation.

Acceptable Solution A59(c)

A “manageable drainage area” refers to an area of open soil that can be managed (at any given time) within the limits of the specified ESC treatment standard without the need for the placement of erosion control measures (e.g. mulching) on any part of the soil.

On a well-managed site, it is typical for a “manageable drainage area” to consist of a series of “sub-areas” interconnected by temporary or permanent drainage channels. A “sub-area” is an area within a given sub-catchment fully contained within a set of drainage control structures designed to minimise the risk of rill erosion within that area.

Acceptable Solution A60(a)

Compliance with this clause required compliance with Performance Criterion P37.

Unless otherwise directed by an approved Site Stabilisation Plan, Landscape Plan, Revegetation Plan, or Vegetation Management Plan, topsoil should be placed at a minimum depth of 75mm on slopes 4:1 (H:V) or flatter, and 50mm on slopes steeper than 4:1.

Further discussion on soil preparation and treatment prior to planting is provided in Appendix C – *Soils and revegetation*.

Performance Criterion P61

Local environment includes local wildlife.

SITE INSPECTION AND MONITORING**Acceptable Solution A62**

Personnel preparing and/or supervising the preparation of the Monitoring and Maintenance Program must, collectively, have the following capabilities:

- (i) an understanding of the local environmental values that could potentially be affected by the proposed works; and
- (ii) a good working knowledge of the site’s Erosion and Sediment Control (ESC) issues, and potential environmental impacts, that is commensurate with the complexity of the site and the degree of environmental risk; and
- (iii) a good working knowledge of current best practice ESC measures appropriate for the given site conditions and type of works; and
- (iv) a good working knowledge of the correct installation, operational and maintenance procedures for the full range of ESC measures used on the site.

Refer to A1(a) for discussion on “potential environmental risk “.

Acceptable Solution A63(a)

Discussion on scheduling and conducting site inspections by internal and external parties is provided in Chapter 7 – *Site inspection*.

In those instances where specific site monitoring stations are identified within the Monitoring and Maintenance Program, then:

- during periods of water discharge from the site, water quality samples are collected at each monitoring station at least once on each calendar day until such discharge stops; and
- a minimum of 3 water samples are taken and analysed, and the average result used to determine quality.

Sediment basin water quality samples are taken at a depth no greater than 200mm above the top surface of the settled sediment within the basin.

Current (2008) best-practice procedures for “high-risk” sites, requires regular ESC audits to be:

- (i) undertaken by a person suitably qualified and experienced in erosion and sediment control that can be verified by an independent third-party (this person must not be an employee or agent of the principal contractor); and
- (ii) conducted on the next business day following a rainfall event in which greater than 10mm of rainfall has been recorded by the Bureau of Meteorology rain gauge nearest to the site; and
- (iii) conducted at intervals of not more than one (1) calendar month commencing from the day of site disturbance until all disturbed areas have been adequately stabilised against erosion to the acceptance of the relevant regulatory authority; and
- (iv) conducted using an appropriate Site Inspection Checklist.

“High-risk sites” are work sites that:

- satisfy the requirements of a high-risk site as defined by either the State or local government; or
- satisfy the requirements of those risk categories greater than high-risk (such as extreme-risk) where such categories have been defined (i.e. score a hazard rating equal to or greater than the “critical hazard value”).

Discussion on the assessment of *erosion hazard* and *site risk assessment* is presented in Chapter 3 – *Site planning*, and Appendix F – *Erosion hazard assessment*.

ESC audits must include, as a minimum:

- copies of all original Site Inspection Checklists; and
- non-conformance and corrective action reports;
- *Sediment Basin* water quality and site discharge water quality monitoring results;
- a plan showing the areas of completed soil stabilisation; and
- rainfall records including date and rainfall depth.

Acceptable Solution A64

Discussion on scheduling and conducting of site inspections is provided in Chapter 7 – *Site inspection*.

SITE MAINTENANCE

Performance Criterion P65

Proper working order includes maintaining the required hydraulic capacity and operational effectiveness.

Acceptable Solution A65(b)

Current (2008) best practice requirements for the maintenance of sediment control devices requires these devices to be maintained and made fully operational as soon as reasonable and practicable in accordance with Table 6.1 of Chapter 6 – *Site management*.

The top of a *Sediment Basin*'s sediment storage volume must be clearly identified by the horizontal member of a marker post (cross).

G5 References

1. Brisbane City Council, 2000. “*Erosion and Sediment Control Standard – Version 9*”. Brisbane City Council.
2. Landcom, 2004. “*Managing Urban Stormwater: Soils and Construction – Volume-1*”, Landcom, New South Wales Government, ISBN 0-9752030-3-7.
3. Sitewise, (undated). “*Urban Soil Erosion and Sediment Control – Resource Pack*”. NSW Department of Land and Water Conservation.