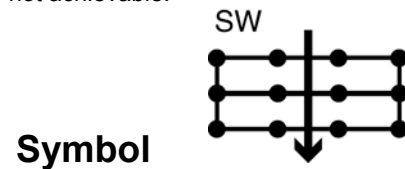


# Sediment Weirs

## SEDIMENT CONTROL TECHNIQUE

Type 1 System		Sheet Flow		Sandy Soils	✓
Type 2 System	✓	Concentrated Flow	✓	Clayey Soils	✓
Type 3 System	[1]	Supplementary Trap		Dispersive Soils	

[1] Type 3 classification may apply if critical design parameters are not achievable.



**Photo 1 – Sediment weir (up-slope face) showing aggregate filter**



**Photo 2 – Sediment weir used as a control structure around a filed (drop) inlet**

### Key Principles

1. Sediment trapping is achieved by both particle settlement within the settling pond formed by the dam (high flows), and by the filtration of minor flows passing through the aggregate and/or geotextile filter.
2. The critical design parameter for optimising particle settlement is the 'surface area' of the settling pond. The hydraulic properties of the weir are critical in achieving the optimum settling pond conditions, which depends on the stage-discharge relationship of the embankment.
3. The critical design parameters for the filtration process are the design flow rate for water passing through the structure (which is related to the depth of water), and the surface area and flow resistance of the weir.
4. Geotextile filters provide superior filtration performance, especially within short-term installations. If an excavated sediment collection pit/trench is incorporated into the settling pond, then the use of a geotextile filter should be considered essential.

### Design Information

*The following design information specifically relates to off-stream installations. The design of sediment weirs located within major stormwater drains and ephemeral waterways is discussed within a separate fact sheet located within the 'Instream Sediment Control' sub-category.*

Sediment weirs may contain up to three different categories of rock, those being:

- The primary core rock, which makes up the bulk of the vertical weir.
- Armour rock (splash pad), which protects the channel bed downstream of the weir from the erosive force of overtopping flows.
- Filter aggregate, which is placed on the upstream face of the weir.

In most cases, the same rock is specified for the core of the sediment weir and the upstream filter. Typical size of filter aggregate is 15 to 25mm nominal diameter.

In situations where there is poor access to the weir, then straw bales can be used as the central core material. Alternatively, a *Modular Sediment Barrier* can be used.

The minimum rock size for the splash pad 'armour' rock is 225mm nominal diameter.

The use of geotextile filters (minimum 'bidim' A34 or equivalent), in addition to the aggregate filter, is preferred in most construction site situations where the sediment weir is likely to have an operational life of a few months.

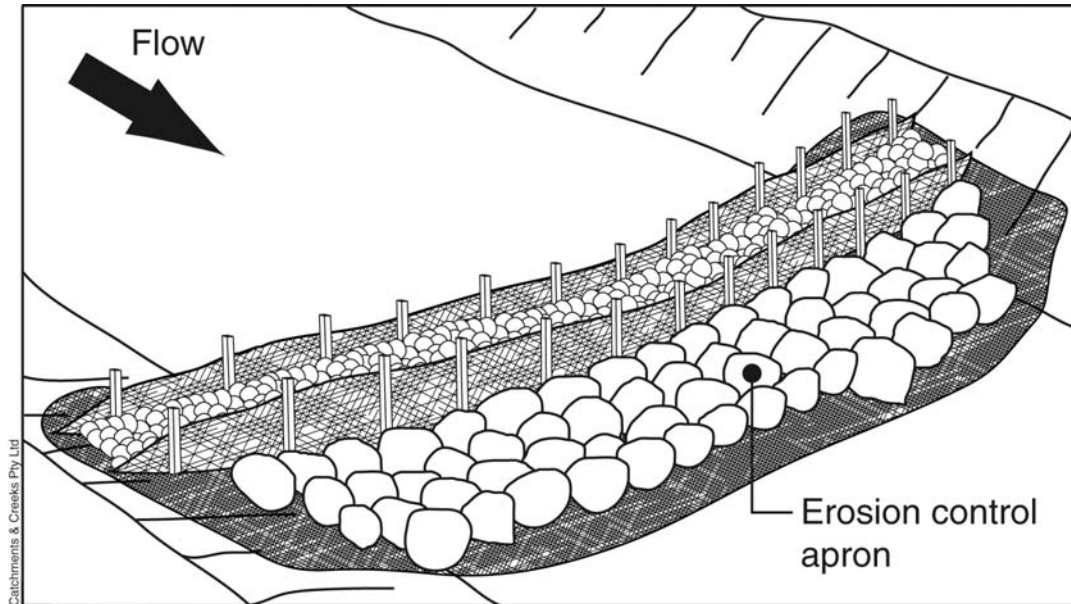


Figure 1 – Sediment weir with downstream rock splash pad

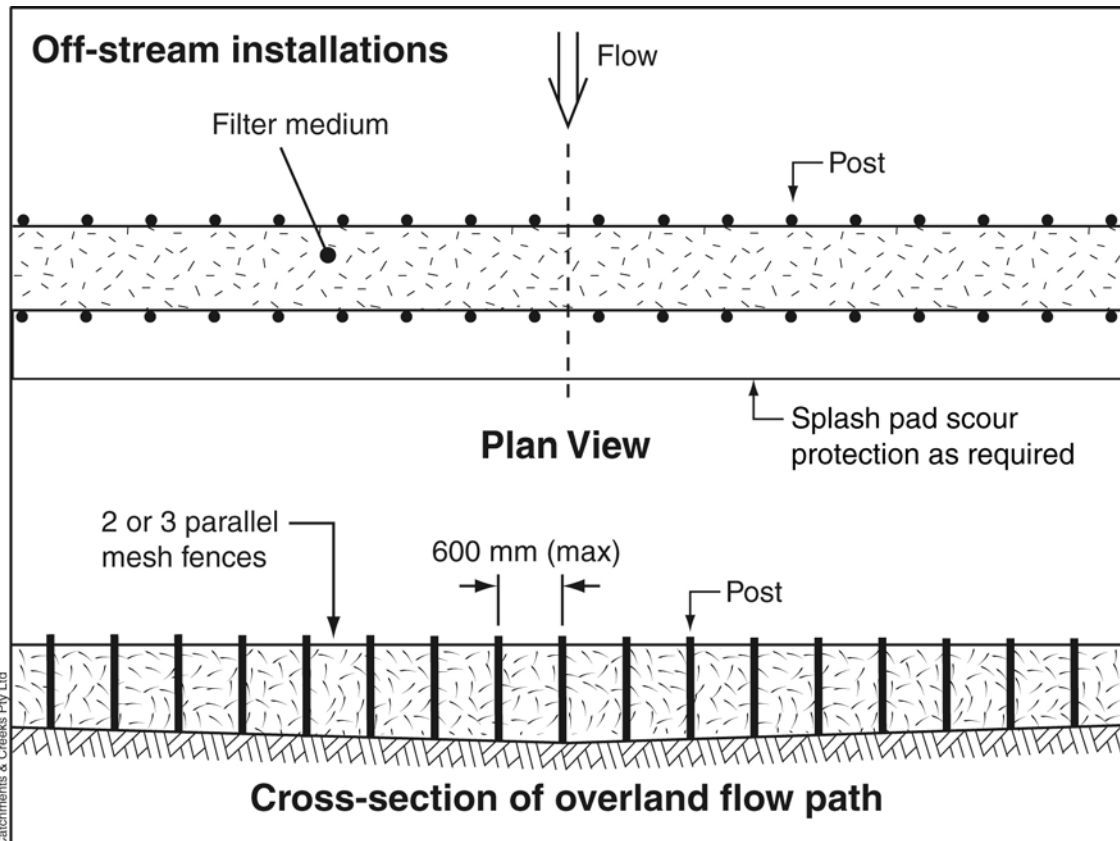
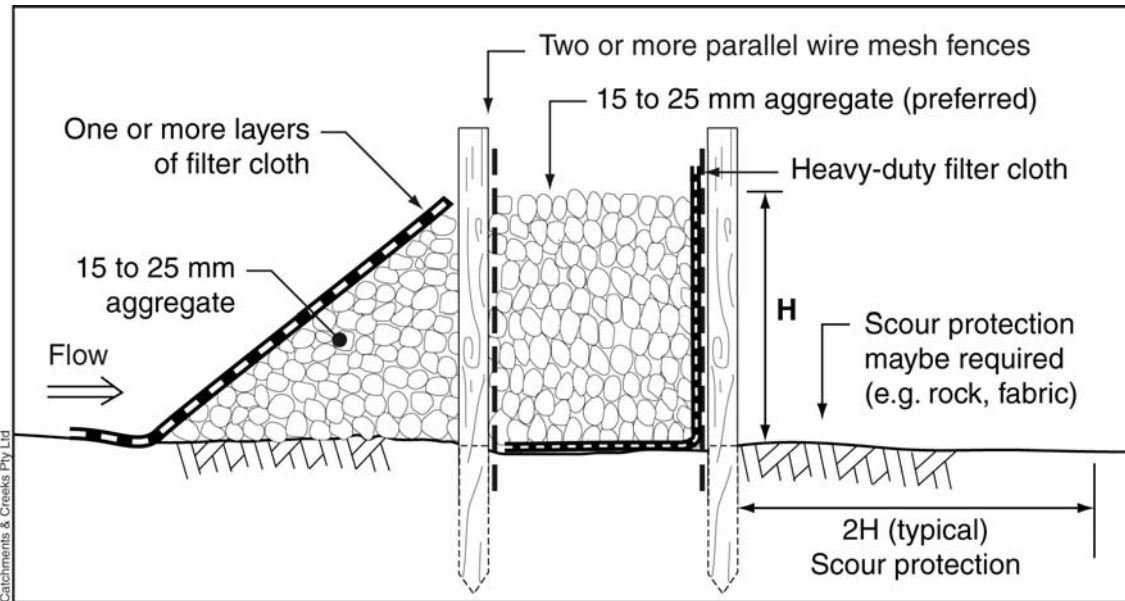
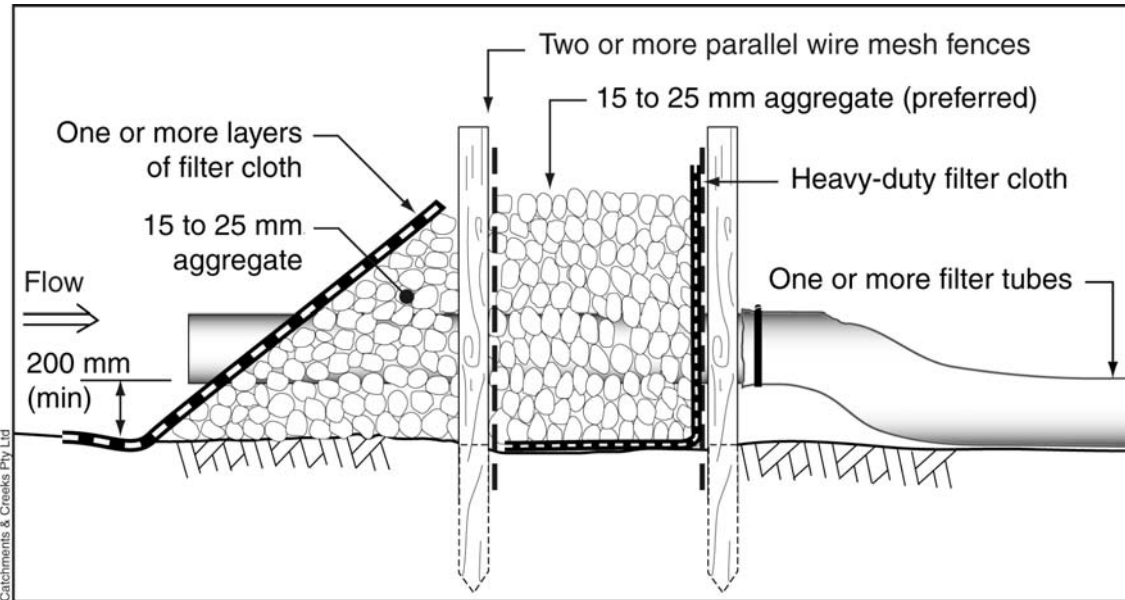


Figure 2 – Typical layout of a sediment weir installed within an overland flow path



**Figure 3 – Sediment weir with additional upstream geotextile filter**



**Figure 4 – Integration of filter tubes into a sediment weir**



Photo supplied by Adam Pullen

**Photo 3 – Installation of an off-stream sediment weir**



Photo supplied by Catchments & Creeks Pty Ltd

**Photo 4 – Sediment weir used as a control structure around a field (drop) inlet**

The use of geotextile filters is considered to provide superior filtration performance, especially within short-term installations (Figure 3 & 4). Consideration should, however, be given to the placement of several layers of overlapping fabric, thus allowing each layer to be removed individually once the fabric becomes blocked with sediment.

### Design Procedure

1. Determine the design flow rate (Q) for water passing through the weir (including upstream filter) just prior to flows overtopping the spillway (Figure 5), as well as the design discharge ( $Q_{WEIR}$ ) for overtopping flows.
2. Determine the desirable settling pond surface area ( $A_s$ ) from Table 1 based on the design flow rate (Q). Unless otherwise specified, choose a critical particle size of 0.05mm.
3. Determine the maximum allowable water level within the settling pond. This may be based on site constraints, or related to flooding and/or public safety issues.
4. Determine the required width of the sediment weir (W). The width (perpendicular to the direction of flow) may be limited by site constraints, or controlled by the hydraulic management of overtopping flows. The hydraulic analysis of overtopping flows is normally based on weir equations—refer to the separate fact sheet '*Chutes Part 1: General Information*'.
5. Select the required crest elevation of the sediment weir to achieve the desired settling pond surface area. Ensure the spillway crest is sufficiently below the maximum allowable water elevation to allow for expected overtopping flows (this may be an iterative process).

Where necessary, the settling pond may need to be excavated (expanded) to achieve the required surface area at a given water level.

6. Select the type of filtration system using Table 3 as a guide.
7. Determine the maximum allowable head loss ( $\Delta H$ ) through the weir including upstream filter. If flow conditions downstream of the sediment weir are such that there is little or no backwater effects during the design storm, then assume  $\Delta H$  is equal to the height of the sediment weir (H).

If flow depths downstream of the sediment weir are expected to be significant, then the maximum allowable head loss ( $\Delta H$ ) should be taken as the expected variation in water level across the weir during the design discharge.

8. Select a 'design' blockage factor (B.F.) using Table 4 as a guide.
9. Use the design information provided below to determine the make-up and thickness of the weir and filter required to achieve the desired stage–discharge relationship.
10. If the available pond surface area is insufficient to settle the required particle size, then the efficiency of the sediment trap may be improved by placing filter cloth across the upstream face of the weir (if not already used). In addition, *Filter Tubes* (refer to *Filter Tube Dams*) can be incorporated into the weir (Figure 4). Note the filter tube intake pipes need to be set at an elevation above the expected settled sediment depth.
11. If excessive quantities of sediment are likely to enter the sediment trap, then assess the benefits of excavating a sediment collection pit just upstream of the weir.
12. Assess the need for safety fencing to be placed around the settling pond.

#### (a) *Settling pond:*

Table 1 provides the required pond surface area per unit flow rate for various nominated 'critical' sediment particle sizes. The critical sediment particle size for a sediment weir may be assumed to be 0.05mm unless otherwise directed. The chosen critical sediment size should reflect the environmental values of the receiving water body and the expected weather conditions. In some cases the critical particles size will be specified within a local Stormwater Management Plan or Erosion and Sediment Control Standard.

Ideally, the settling pond should have a length (in the main direction of flow) at least three times its average width. If the pond length is less than three times its average width, or the inflow is primarily through the discharge of a high velocity pipe (resulting in inflow 'jetting'), then the pond area should be increase by 20% from the values presented in Table 1.

It is noted that achieving the minimum pond surface area may not be practicable in all circumstances, in which case a greater focus should be placed on the design of the filter medium and/or the incorporation of filter tubes (Figure 4).

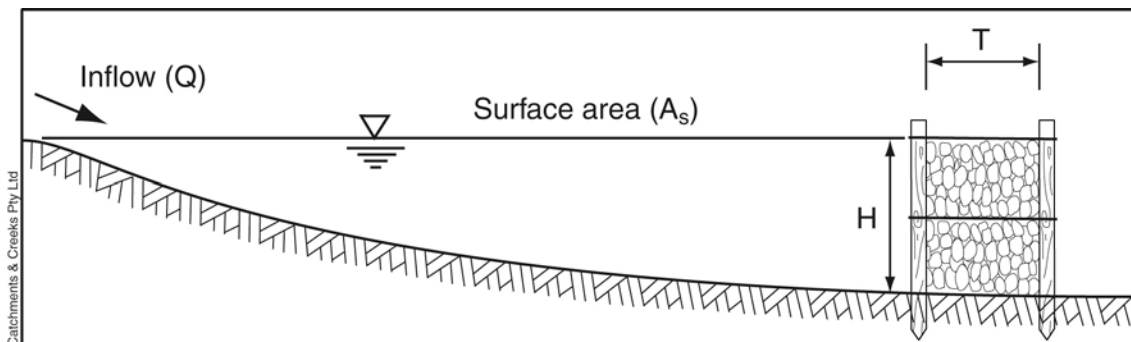
**Table 1 – Minimum settling pond surface area per unit inflow rate**

Design standard	Critical sediment size (mm)	Surface area of settling pond per unit discharge (m <sup>2</sup> /m <sup>3</sup> /s) <sup>[1]</sup>			Allowable through-velocity (m/s)
		10° C <sup>[2]</sup>	15° C <sup>[2]</sup>	20° C <sup>[2]</sup>	
Type 3 sediment trap	0.50	6	5.2	4.6	0.3
	0.20	38	33	29	0.3
	0.15	67	60	52	0.3
Type 2 sediment trap	0.10	150	130	115	0.2
	0.05	600	525	460	0.2
Type 1 sediment trap	0.04	940	820	720	0.2
	0.02	3700	3230	2860	0.2

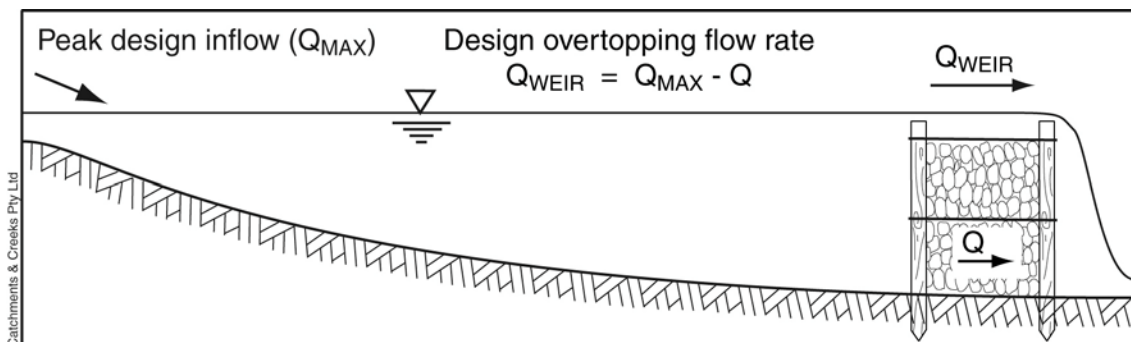
[1] Pond area is based on a rectangular pond operating with uniform inflow conditions across its width.

[2] Assume a pond temperature the same as the typical rainwater temperature during the time of year when the pond is likely to be operating at capacity.

Two design flow rates are used in the design of sediment weir. The low flow rate (Q) is the flow rate required to pass through the filtration system just prior to flows overtopping the weir crest (Figure 5). The maximum design flow condition (Q<sub>WEIR</sub>) is when peak waters are achieved within the settling pond (Figure 6).



**Figure 5 – Minimum design flow condition**



**Figure 6 – Maximum design flow condition**

**(b) Weir structure:**

Maximum 600mm spacing of support posts/stakes. The posts should consist of 1500mm<sup>2</sup> (min) hardwood, 2500mm<sup>2</sup> (min) softwood, or 1.5kg/m (min) steel star pickets.

Fencing should consist of wire or steel mesh minimum 14 gauge with a maximum mesh opening of 200mm.

The sediment weir may consist of two or more parallel wire mesh fences filled with an appropriate flow control medium such as aggregate or straw bales (refer to Table 2). Sediment fence fabric may also be used to achieve the desired stage–discharge relationship; however the fabric must be placed on the upstream side of the most downstream wire mesh fence to reduce the risk of sediment blockage of the fabric.

The core material placed between the wire mesh fences is primarily used to achieve the desired stage–discharge relationship; however, this material may also be used to provide secondary filtration of low flows.

The wire mesh should be securely tied to the inside of the support posts to prevent the mesh from being torn from the post during placement of the primary core material. During the filling operation, the whole weir should be bound with horizontal wire ties at a maximum vertical spacing of 400mm. Figures 11 to 16 demonstrate the installation process.

The weir should be appropriately keyed (minimum 200mm) into the sides of any earth abutments to control seepage.

Minimum desirable thickness of the weir core (in direction of flow) is 0.6m, however this may not be suitable in all circumstances.

Maximum height at centreline of the weir is 1.5m, otherwise the design should be assessed for stability by a suitably qualified person. The crisscross horizontal wire ties are used to lace the fences together provide the necessary structural support to the wire.

In most cases, the same rock is specified for the core of the sediment weir and the upstream filter. Typical size of filter aggregate is 15 to 25mm nominal diameter.

The properties of the various core infill materials are presented in Table 2.

**Table 2 – Properties of various sediment weir core infill materials**

Type	Material	Properties
Aggregate	15 to 25mm aggregate	Suitable as a filter media. Medium trapping efficiency. High maintenance requirements.
	25 to 75mm aggregate	Not suitable as a filter media. Low trapping efficiency. Low to medium maintenance requirements.
Straw	Straw bales	Generally not preferred because no information is available to determine the hydraulic characteristics of straw bales. Generally used when the sediment weir is constructed in a location where site access is poor and there is no feasible means of transporting sufficient quantities of aggregate to the weir.
Fabric	Woven sediment fence fabric	Woven sediment fence fabric may be used within the weir core to help regulate the rate of flow passing through the weir. Woven fabrics must be placed 'upstream' of a non-woven fabric (filter cloth) if both are attached to the downstream mesh fence.

**(c) Downstream splash pad (energy dissipater):**

A geotextile or rock apron should extend downstream from the toe of the weir a sufficient distance to prevent channel erosion, or a distance equal to twice the height of the dam, whichever is the greater.

The minimum rock size for the splash pad 'armour' rock is 225mm nominal diameter.

**(d) Filter media:**

The entire upstream face of the weir should be covered with an appropriate filter medium. The primary purpose of the upstream filter media is to filter sediment from water passing through the weir. This filter medium is therefore highly susceptible to sediment blockage and may need to be replaced several times during the operation of the sediment weir.

The filter medium is required to perform the following two tasks:

- slow the passage of water through the weir so that an upstream settling pond will form with the required surface area to allow adequate gravitational settlement; and
- filter sediment from the water that passes through the filter medium.

Locating the primary filter upstream of the weir allows regular maintenance without disturbance to the main weir structure.

The properties of the various filter media are presented in Table 3.

**Table 3 – Properties of various upstream filter media**

Type	Material	Properties
Filter cloth	Heavy-duty filter cloth (minimum 'bidim' A34 or equivalent) one or more layers	Medium trapping efficiency. Possible high maintenance requirements (the aim is for the operational life of the trap to be less than the time required for the fabric to block with sediment).
Aggregate	15 to 25mm aggregate	Initially poor filtering capacity until partial sediment blockage of the aggregate occurs, after which medium trapping efficiency. Medium maintenance requirements.
Sandbags	Woven bags filled with coarse sand	Medium to high filtration of sand and silt-sized particles. Poor filtration of clay-sized particles.
	Open weave bags filled with gypsum	Potential treatment of dispersive clays to improve settlement characteristics and reduce turbidity levels.

**(e) Aggregate filter hydraulics:**

The head loss ( $\Delta H$ ) of a rock filter can be determined using Equation 1, which is based on a rectangular rock-filled medium of width 'T'.

$$\Delta H^{1.5} = \frac{1000 \cdot Q \cdot T^{0.5}}{B \cdot F \cdot [15.2 - 0.0068(d)] \cdot W \cdot d^{0.5}} \quad (\text{Eqn 1})$$

where:

- Q = Flow rate (assuming no blockage) [ $\text{m}^3/\text{s}$ ]
- d = mean ( $d_{50}$ ) size of the filter rock [mm]
- W = width of rock filter dam across the direction of flow [m]
- $\Delta H$  = head loss through rock filter [m]
- T = thickness of rock filter in the direction of flow [m]

Notes on Equation 1:

- It is assumed that the effective height of the rock filter (H) is equal to the head loss ( $\Delta H$ ) through the structure, i.e. it is assumed that there is no hydraulic back pressure on the downstream face of the rock filter.
- The equation was developed from research work presented by Jiang et al., within Fifield (2001).
- Given the complexity of many rock filters, the equation may not be accurate in all circumstances, but is assumed to be satisfactory for design purposes.

Unit flow rates for rectangular rock-filled structures based on Equation 1 are provided in Tables 5 to 7 for various rock sizes and blockage factors.

If the core of the weir contains rock larger than 100mm in diameter, then it may be assumed that this rock does not provide any measurable hydraulic resistance to the passage of water through the weir.

As an alternative to Equation 1, the allowable flow rate (Q) can be determined using Equation 2 if the maximum allowable head loss ( $\Delta H$ ) is known.

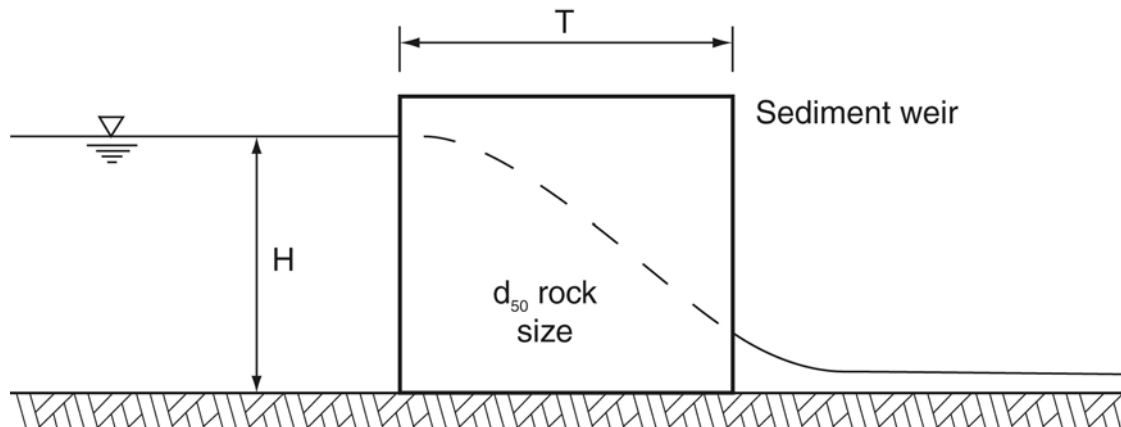
$$Q = (B.F.) [15.2 - 0.0068(d)] \frac{W \cdot \Delta H^{1.5} \cdot d^{0.5}}{1000 T^{0.5}} \quad (\text{Eqn 2})$$

**Table 4 – Blockage factors for filter mediums**

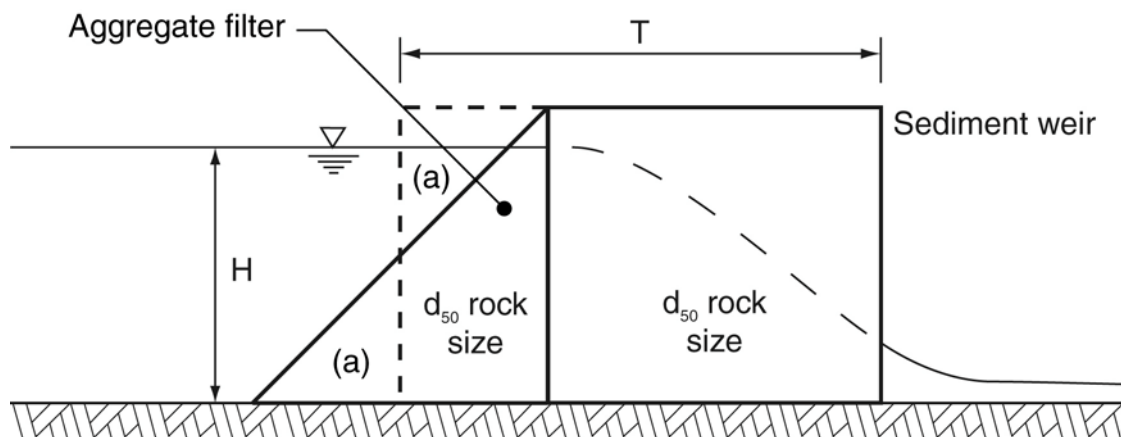
Blockage factor (B.F.)	Appropriate usage
1.0	When assessing the 'As Constructed' maximum flow rate.
0.9	Sediment traps operating in coarse-grained soils where the runoff of fine silts and clays is expected to be only minor.
0.5	Default design value. Sediment traps likely to experience more than one storm event.

Ideally, the sediment weir should be able to fully discharge (de-water) the settling pond over **no less** than 8 hours to allow sufficient time for particle settlement. Settling ponds that can drain (from full) in less than 8 hours may not achieve optimum sediment capture. Settling ponds that drain (from full) over a period greater than 8 hours may indicate the need for maintenance of the filter medium.

Figures 7 and 8 provide examples of typical sediment weir profiles and the equivalent filter barrier hydraulic analysis profile.



**Figure 7 – Sediment weir without upstream filter**



**Figure 8 – Sediment weir with upstream aggregate filter**



**Table 5 – Flow rate per unit width for rock filters (no blockage factor)**

$\Delta H$ (m)	T = 0.3m			T = 0.5m			T = 0.6m			T = 1.0m		
	Mean rock size (mm)			Mean rock size (mm)			Mean rock size (mm)			Mean rock size (mm)		
	25	50	75	25	50	75	25	50	75	25	50	75
Unit flow rate (L/s/m)												
0.2	12	17	21	10	13	16	9	12	15	7	9	11
0.3	23	32	38	17	24	30	16	22	27	12	17	21
0.4	35	49	59	27	38	46	25	34	42	19	27	32
0.5	49	68	82	38	53	64	34	48	58	27	37	45
0.6	64	89	108	49	69	84	45	63	76	35	49	59
0.8	98	137	166	76	106	129	69	97	118	54	75	91
1.0	137	192	232	106	149	180	97	136	164	75	105	127
1.5	252	352	427	195	273	331	178	249	302	138	193	234
2.0	388	543	657	301	420	509	274	384	465	213	297	360
2.5	542	758	918	420	587	711	383	536	649	297	415	503
3.0	713	997	1207	552	772	935	504	705	853	390	546	661

**Table 6 – Flow rate per unit width for rock filters (10% blockage factor)**

$\Delta H$ (m)	T = 0.3m			T = 0.5m			T = 0.6m			T = 1.0m		
	Mean rock size (mm)			Mean rock size (mm)			Mean rock size (mm)			Mean rock size (mm)		
	25	50	75	25	50	75	25	50	75	25	50	75
Unit flow rate (L/s/m)												
0.2	11	15	19	9	12	14	8	11	13	6	8	10
0.3	20	28	34	16	22	27	14	20	24	11	16	19
0.4	31	44	53	24	34	41	22	31	37	17	24	29
0.5	44	61	74	34	47	57	31	43	52	24	33	40
0.6	57	80	97	44	62	75	41	57	69	31	44	53
0.8	88	124	150	68	96	116	62	87	106	48	68	82
1.0	123	173	209	96	134	162	87	122	148	68	95	114
1.5	227	317	384	176	246	297	160	224	272	124	174	210
2.0	349	488	591	271	378	458	247	345	418	191	267	324
2.5	488	682	826	378	529	640	345	483	584	267	374	453
3.0	642	897	1086	497	695	841	454	634	768	351	491	595

**Table 7 – Flow rate per unit width for rock filters (50% blockage factor)**

$\Delta H$ (m)	T = 0.3m			T = 0.5m			T = 0.6m			T = 1.0m		
	Mean rock size (mm)			Mean rock size (mm)			Mean rock size (mm)			Mean rock size (mm)		
	25	50	75	25	50	75	25	50	75	25	50	75
Unit flow rate (L/s/m)												
0.2	6	9	10	5	7	8	4	6	7	3	5	6
0.3	11	16	19	9	12	15	8	11	13	6	9	10
0.4	17	24	29	13	19	23	12	17	21	10	13	16
0.5	24	34	41	19	26	32	17	24	29	13	19	22
0.6	32	45	54	25	35	42	23	32	38	17	24	30
0.8	49	69	83	38	53	64	35	49	59	27	38	46
1.0	69	96	116	53	74	90	49	68	82	38	53	64
1.5	126	176	213	98	136	165	89	125	151	69	97	117
2.0	194	271	328	150	210	254	137	192	232	106	149	180
2.5	271	379	459	210	294	356	192	268	325	149	208	251
3.0	356	498	603	276	386	467	252	352	427	195	273	331

**(f) Filter cloth hydraulics:**

The head loss through a layer of filter cloth can be determined from the permittivity ( $\psi$ ) of the reported fabric in accordance with AS 3706-9.

$$\Delta H = \frac{Q}{(B.F.).A.\psi} \quad (\text{Eqn. 3})$$

where:

- $\Delta H$  = Hydraulic head loss through geotextile [m]
- $Q$  = Total flow rate through the geotextile [ $\text{m}^3/\text{s}$ ]
- $A$  = Surface area of the geotextile [ $\text{m}^2$ ]
- $\psi$  = Permittivity of the geotextile (AS 3706-9) [ $\text{s}^{-1}$ ]

Notes on Equation 3:

- Equation 3 assumes hydraulic pressure (i.e. water) exists on both sides of the fabric, i.e. the cloth is not 'damming' the water like most woven fabrics do.

The permittivity for various grades of 'bidim' filter cloth can be determined from Table 5.

**Table 8 – Flow rate per unit width for various grades of 'bidim' filter cloth (no blockage allowance)**

bidim grade =	A12	A14	A24	A29	A34	A44	A64
Flow rate @ 100mm head <sup>[1]</sup> ( $\text{L/s/m}^2$ )	512	454	342	242	217	161	118
Permittivity (AS 3706-9) ' $\psi$ ' ( $\text{s}^{-1}$ )	5.12	4.54	3.42	2.42	2.17	1.61	1.18

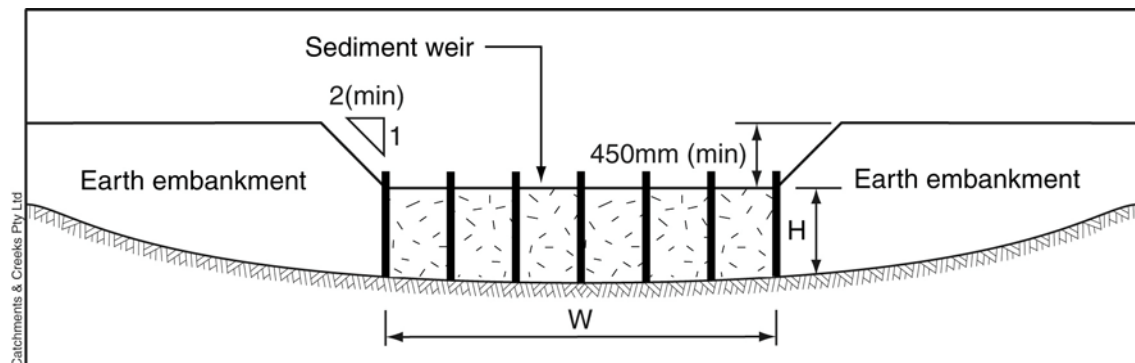
[1] Manufacturer's specified flow rate at a constant head of 100mm based on AS 3706-9.

**(g) Earth abutments (if required):**

If the sediment weir abuts into constructed earth embankments, then such embankments should be formed with stable bank slopes appropriate for the soil conditions. Typically bank slopes should not be steeper than 2:1 (H:V) if temporary, or 4:1 if the embankments are grassed and are required to be mown.

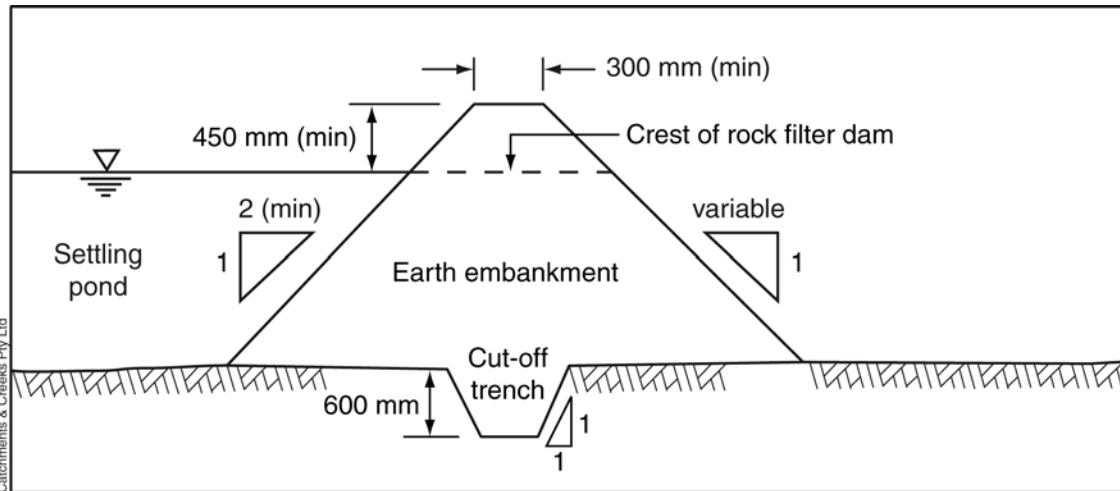
The crest of constructed earth embankments should be at least 450mm above the crest of the sediment weir if the embankments have an operational life less than 12 months, with a minimum freeboard above the design maximum settling pond water level of 150mm (Figure 9).

If the earth embankments have an operational life greater than 12 months, then an appropriate allowance should be made for settlement of any constructed embankments.



**Figure 9 – Sediment weir integrated into fill embankments**

Earth embankments in excess of 1m high are normally keyed into the natural soil with the use of a 600mm deep cut-off trench (Figure 10) that both anchors the embankment and reduces the risk of damaging seepage flows under the embankment.



**Figure 10 – Typical dimensional requirements for constructed fill abutments**

**(h) Instream sediment weirs:**

The design and operation of instream sediment weirs are discussed in a separate fact sheet located within the *Instream sediment control* section. Instream sediment weirs differ from off-stream structures in the following ways:

- instream designs are normally based on the stream's dry weather flow rate, rather than a specific storm event;
- the weirs are normally formed with a slight V-shaped profile in order to focus overtopping flows towards the centre of the channel.



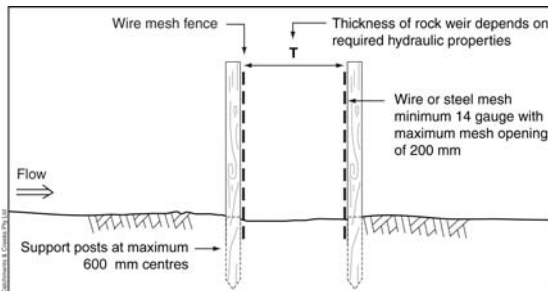
**Photo 5 – Instream sediment weir with downstream splash pad**



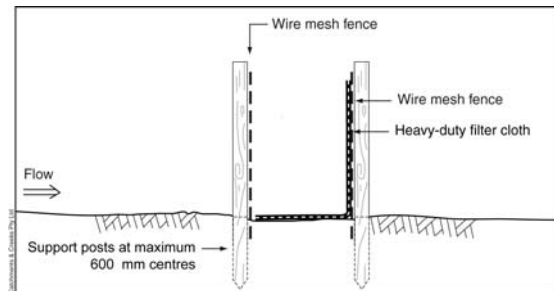
**Photo 6 – Sediment weir (left) showing aggregate infill**

**(i) Installation procedure:**

Install the support posts at a maximum 600mm centres and attach the wire mesh to the inside of the posts (Figure 11). Place filter cloth and/or woven fabric (as specified) on the upstream side of the most downstream fence (Figure 12).

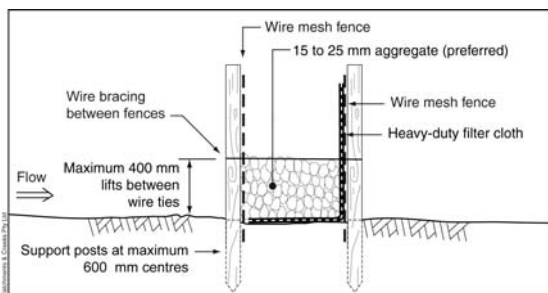


**Figure 11 – Placement of support posts and wire mesh**

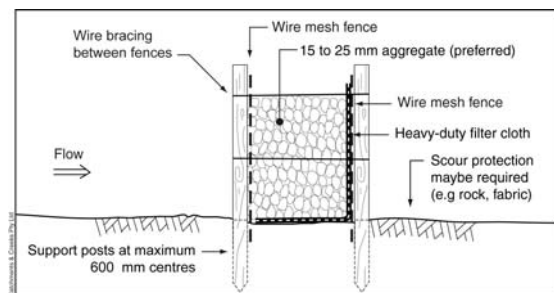


**Figure 12 – Placement of filter cloth on downstream wire mesh (where necessary, this may be replaced by a woven fabric to reduce the flow rate through the weir)**

Install the internal filter medium between the parallel fences. If aggregate is used, it should be placed in maximum 400mm lifts (Figure 13). After each 400mm lift, lace diagonal support posts together using fencing wire to improve stability of the weir. Repeat this process until the weir reaches the specified height (Figure 14).

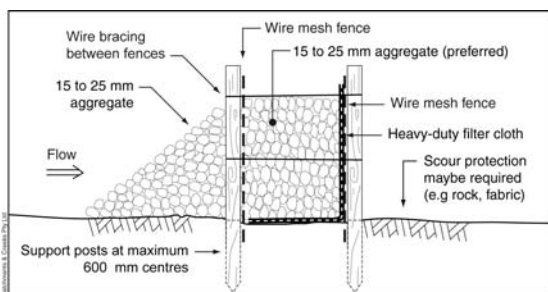


**Figure 13 – Placement of first layer of core material**

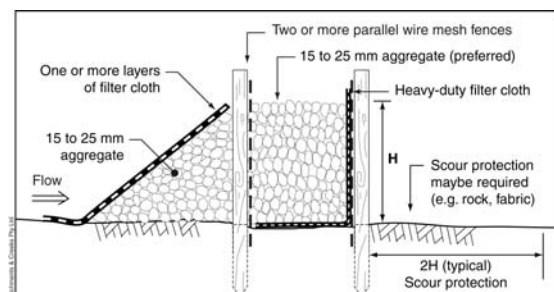


**Figure 14 – Placement of subsequent layers of core material**

Install the specified upstream filter material to the upstream face of the sediment weir. If fabric filter is to be used, consider attaching several layers of filter cloth, thus allowing each layer to be progressively removed as the fabric has become blocked with sediment. If an aggregate filter is used, it should be formed against the sediment weir frame at a slope of 2:1 (H:V) or flatter (Figure 15). Place filter cloth (if specified) on the upstream side of the aggregate (Figure 16).



**Figure 15 – Placement of upstream filter medium**



**Figure 16 – Placement of geotextile filter (optional)**

**Reference:**

Fifield, J.S. 2001, *Designing for Effective Sediment and Erosion Control on Construction Sites*. Forester Communications, California. ISBN 0-9707687-0-2.

## Description

A self-supporting vertical rock weir usually constructed from uniform-sized rocks, with a filter medium placed on the upstream face of the weir.

The upstream filter medium typically consists of either one or more layers of filter cloth placed on an aggregate batter.

A gabion wall acts in a manner similar to a sediment weir; however, the rock fill normally used within gabions may be too coarse to provide the desirable hydraulic and filtration requirements.

## Purpose

Typically used as a Type 2 sediment trap, but can be classified as a Type 3 sediment trap if the settling pond has insufficient surface area.

Used as an alternative to a *Rock Filter Dam* when space is limited.

Most commonly used as a sediment trap at the end of minor table drains and drainage channels with a catchment area less than 0.25ha.

Can also be used as a sediment trap around large stormwater field (drop) inlets.

## Limitations

Limited ability to control turbidity levels or trap fine sediments, except during periods of low flow.

## Advantages

The sediment weirs are generally durable structures that rarely experience accidental damage as compared to most Type 3 sediment traps.

The upstream aggregate and geotextile filters are easy maintained (i.e. replaced) during maintenance operations.

Does not necessarily require heavy machinery to install.

Smaller footprint compared to a *Rock Filter Dam*.

## Disadvantages

The filter medium may regularly block with sediment requiring its replacement.

Geotextile filters can be difficult to replace once covered in mud.

Fine sediments (e.g. clay particles) readily pass through most sediment weirs.

## Special Requirements

Suitable access must be provided for maintenance.

If the weir is expected to be overtopped by storm flows, then a downstream erosion control splash pad will be required.

An excavated sediment collection pit may be formed immediately upstream of the rock weir to reduce the risk of sediment blockage of the filter medium. However, it is noted that aggregate filters rely on partial sediment blockage to achieve optimum filtration properties.

If an excavated sediment collection pit/trench is incorporated into the settling pond, then the use of a geotextile filter should be considered essential.

Safety risks associated with the settling pond and its backwater (flooding) effects must be given appropriate consideration.

When placed in stream channels, benefits may be achieved by constructing the sediment weir in a V-shape pointing upstream and with the crest of the weir slightly depressed in the centre of the channel. This will concentrate the energy of over-topping flows towards the centre of the channel, thus reducing bank erosion.

## Location

Small, low risk catchment areas typically less than 0.25ha.

Sediment traps located within minor table drains and drainage channels.

A sediment weir can form the outlet structure on a *Sediment Trench* or de-watering *Settling Pond*.

## Site Inspection

Check the clarity of the outflow downstream of the sediment trap.

Check the choice and performance of the filter medium.

Check the dimensions of the settling pond.

Check for potential flows bypassing the filter medium.

Check for displacement of filter material.

Check available sediment storage capacity.

Check if the trap requires maintenance or sediment removal.

## Materials

- Support posts/stakes: 1500mm<sup>2</sup> (min) hardwood, 2500mm<sup>2</sup> (min) softwood, or 1.5kg/m (min) steel star pickets suitable for attaching wire mesh.
- Wire mesh: wire or steel mesh minimum 14-gauge with a maximum mesh spacing of 200mm.
- Primary core rock: 15 to 75mm round or crushed (angular) rock.
- Aggregate filter: 15 to 25mm clean aggregate.
- Geotextile filter fabric: heavy-duty non-woven, needle-punched filter fabric, minimum 'bidim' A34 or equivalent.
- Woven flow control fabric: minimum unit weight of 140gsm, with ultraviolet inhibitors and stabilisers to provide a minimum of 6 months of useable construction life.
- Armour rock (splash pad): well graded, hard, angular, erosion resistant rock, with mean size not less than 225mm.

## Installation

1. Refer to approved plans for location and construction details. If there are questions or problems with the location, or method of installation, contact the engineer or responsible on-site officer for assistance.
2. If required, establish an access track to the sediment trap for construction purposes and ongoing maintenance. Clear only those areas necessary to complete the immediate works.
3. Clear the foundation area of the sediment weir of woody vegetation and organic matter. Delay clearing the up-slope pond area until the weir is formed and is able to act as a suitable sediment trap.
4. If specified on the plans, excavate a cut-off trench along the centre-line of the earth abutments (if any).
5. Cover the foundation area and cut-off trench with heavy-duty filter fabric. Overlap adjoining fabric sheets a minimum of 600mm at all joints.
6. Install the support posts at a maximum 600mm centres, and attach the wire mesh to the inside of the posts. Install the parallel wire mesh fences at the spacing and number specified in the approved plans.
7. Place filter cloth and/or woven fabric (as specified) on the upstream side of the most downstream fence.
8. Install the internal filter medium between the parallel fences. If aggregate is used, it should be placed in maximum 400mm lifts. After each 400mm lift, lace diagonal support posts together using fencing wire to improve stability of the weir. Repeat this process until the weir reaches the specified height.
9. Construct the associated earth abutment (if any). All cut and fill slopes should be 2:1(H:V) or flatter. The downstream face of earth abutments should be 3:1(H:V) or flatter. Earth abutments should be constructed of well-compacted, erosion resistant soil that is free of vegetation and roots. Overfill earth abutments 150mm to allow for settlement.
10. Install the specified upstream filter material to the upstream face of the sediment weir. If fabric filter is to be used, consider attaching several layers of filter cloth, thus allowing each layer to be progressively removed as the fabric has become blocked with sediment. The aggregate filter should be formed against the sediment weir frame at a slope of 2:1 (H:V) or flatter.
11. Clear the settling pond area of woody vegetation and organic matter to the dimensions specified within the plans.
12. Where necessary, excavate the upstream settling pond and/or sediment storage pit in accordance with the approved plans. Excavated pits typically have side slopes of 2:1(H:V) or flatter unless steeper slopes are known to be stable.
13. If overtopping flood flows are possible during operation of the sediment weir, then construct an appropriate splash pad downstream of the weir to control soil erosion.
14. Establish all necessary up-slope drainage control measures to ensure that sediment-laden runoff is appropriately directed into the sediment trap.
15. Take all necessary measure to minimise the safety risk caused by the structure.

## **Maintenance**

1. Check all sediment weirs after each runoff event and make repairs immediately.
2. Inspect all embankments for undercutting or undesirable seepage flows.
3. Ideally, sediment weirs should discharge (from full) over no less than 8 hours. If drainage is too rapid, then additional filter aggregate may be required to achieve optimum hydraulic performance.
4. If flow through the structure is reduced to an unacceptable level, the upstream filter medium (aggregate or filter cloth) should be removed and replaced.
5. If a greater degree of water treatment (filtration) is required, extra geotextile filter fabric should be placed over the upstream face of the structure.
6. Check the structure and downstream channel banks for damage from overtopping flows. Make repairs as necessary.
7. Immediately replace any rock displaced from the downstream splash pad.
8. Remove sediment and restore original sediment storage volume when collected sediment exceeds 10% of the specified storage volume.
9. Dispose of sediment and debris in a manner that will not create an erosion or pollution hazard.

## **Removal**

1. When the up-slope drainage area has been stabilised, remove all materials included deposited sediment and dispose of in a suitable manner that will not cause an erosion or pollution hazard.
2. All water and sediment should be removed from the settling pond prior to the dam's removal. Dispose of sediment and water in a manner that will not create an erosion or pollution hazard.
3. Bring the disturbed area to a proper grade, then smooth, compact and stabilise and/or revegetate as required to minimise the erosion hazard.