

Sediment Basin Riser Pipe Outlets

SEDIMENT CONTROL TECHNIQUE

Type 1 System	✓	Sheet Flow		Sandy Soils	✓
Type 2 System		Concentrated Flow	✓	Clayey Soils	
Type 3 System		Supplementary Trap		Dispersive Soils	



Photo supplied by Catchments & Creeks Pty Ltd

Photo 1 – Twin riser pipes in the process of being installed



Photo supplied by Catchments & Creeks Pty Ltd

Photo 2 – Riser pipe with aggregate filter and trash screen

Design Information

Information contained in this fact sheet refers to the design of riser pipe outlet systems for free draining (dry) sediment basins.

- (a) Pipe size:** The minimum diameter of the outlet pipe should be 250mm.
- (b) Freeboard to spillway crest:** The top elevation of the riser pipe (or oil skimmer if used) should be a minimum 300mm below the crest of the emergency spillway.
- (c) Hydraulic capacity and freeboard:** The primary outlet should be capable of discharging the peak flow from the relevant design storm when the pond water level is no less than 300mm below the crest of the emergency spillway.
- The screened open top of the riser pipe (Figure 1) can be used as a siphon spillway for storms in excess of the basin's design storm. Note; the basin's design storm is different from the design storm for the emergency spillway.
- (d) Drainage holes:** Riser pipe outlet systems should be designed to drain the basin's full settling zone volume in not less than 24 hours (to allow adequate settlement time).
- Minor perforation holes should exist throughout both the settling zone and the sediment storage zone. The primary (i.e. largest) drainage holes are located at the base of the settling zone. These holes are sized using the orifice discharge formula (Equation 1).

$$A_o = \frac{A_s \sqrt{2H}}{C_d T \sqrt{g}} \quad (\text{Eqn 1})$$

where:

A_0 = surface area of primary drainage holes [m²]

A_s = average surface area of the settling zone = V_s/h_s [m²]

V_s = volume of settling zone [m³]

h_s = depth of settling zone [m]

H = head of water above orifice [m]

T = de-watering time [hours]

C_d = discharge coefficient for de-watering holes ($C_d = 0.60$)

g = gravitational constant (9.8m/s²)

Equation 1 does **not** provide an appropriate analysis of basin drainage when multiple primary holes are used at various depths throughout the settling zone.

The de-watering holes must **not** be directly covered by filter cloth, instead spacers should be used to separate the filter from the surface of the riser pipe (Figure 1).

All de-watering holes must be covered with wire mesh if aggregate is used at the primary filter.

De-watering of the sediment storage zone can be achieved by locating additional minor drainage holes within the sediment storage zone.

(e) Primary filtration system:

An outlet riser pipe can be surrounded with a 'pyramid' of aggregate (Figure 2), or a vertical stand of rock-filled gabion baskets wrapped in heavy-duty filter cloth (Figure 3).

Alternatively, filter cloth can be used as the primary filter medium (Figures 1 and 3). Outlet systems that incorporate the use of filter cloth must give appropriate consideration of ongoing maintenance issues, including regular replacement of the filter cloth. It should be noted that maintenance and sediment blockage of the filter cloth will be reduced as the total surface area of the filter cloth is increased.

The filter cloth must **not** be placed in direct contact with the riser pipe. An air gap is essential to ensure hydraulic efficiency of the filter cloth (Figure 4). Thus wire mesh should be wrapped around and secured to the perforated riser pipe before attaching the fabric.

To assist in separating the filter cloth from the riser pipe, vertical timber spacers (Figure 4) can be placed between the riser pipe and wire mesh.

(f) Oil skimmer:

An oil skimmer ring (Figures 1 and 5) is normally placed around the top of the riser pipe to minimise the risk of floating debris and oil from entering the riser pipe.

(g) Debris screen:

A debris screen should be placed over the top of the riser pipe. Typically this screen is incorporated into the oil skimmer.

(h) Anti-vortex device:

An anti-vortex plate should be fitted to the top of the riser pipe as shown in Figure 5.

(i) Anti-flotation weight:

The design of any riser pipe system should include allowance for uplifting (buoyancy) forces on the structure in the form of a weighted concrete base. The weight of the anti-flotation mass (Figure 1) should be no less than 110% of the mass of water displaced by the riser pipe.

Gabion baskets must be securely fastened to the riser pipe if they are to act as the anti-flotation weight.

(j) Anti-seep collar:

At least one anti-seep collar must be placed on the riser pipe to prevent seepage along the outer surface of the pipe.

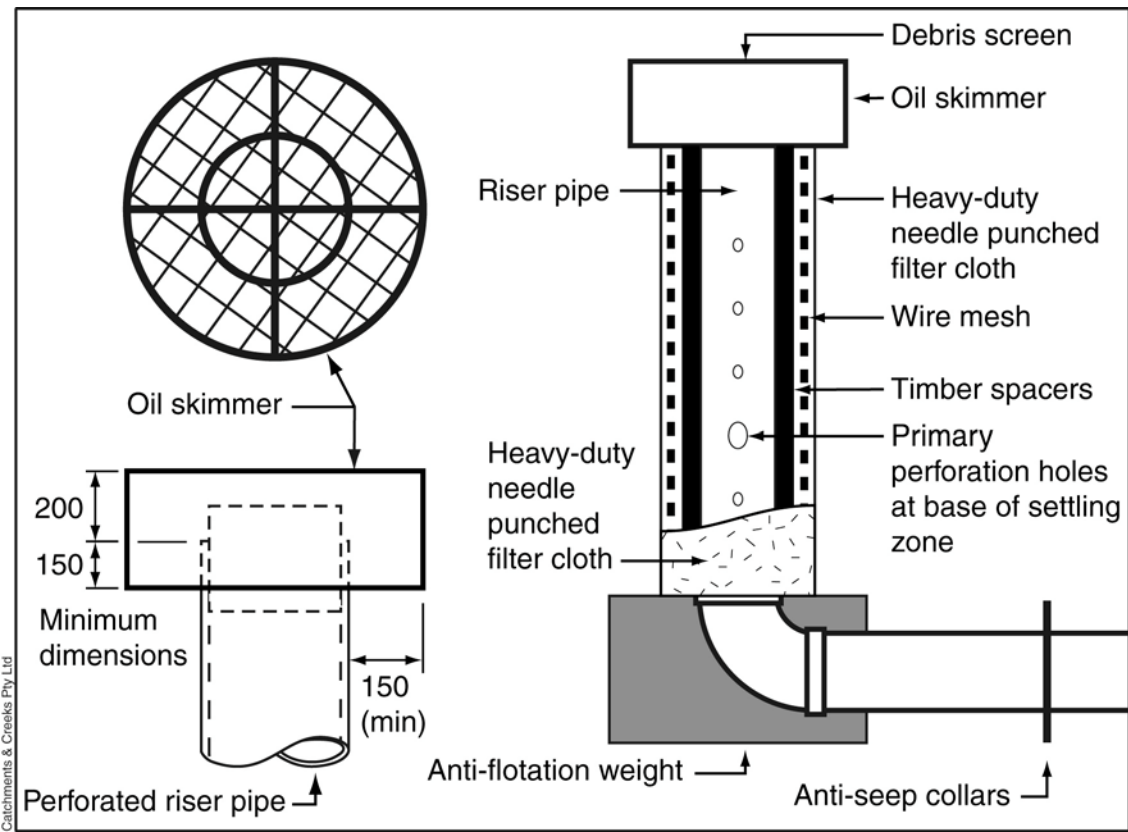

Figure 1 – Typical details of riser pipe outlet with fabric filter

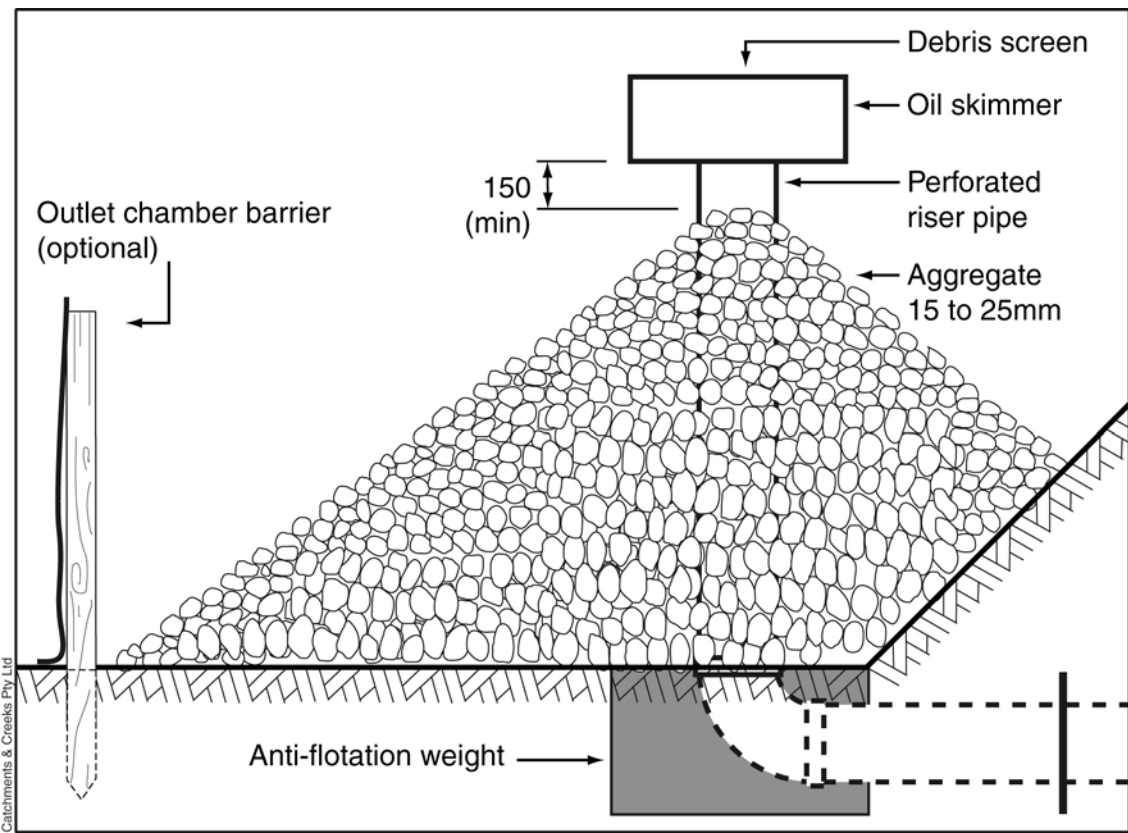

Figure 2 – Typical details of riser pipe outlet with aggregate filter

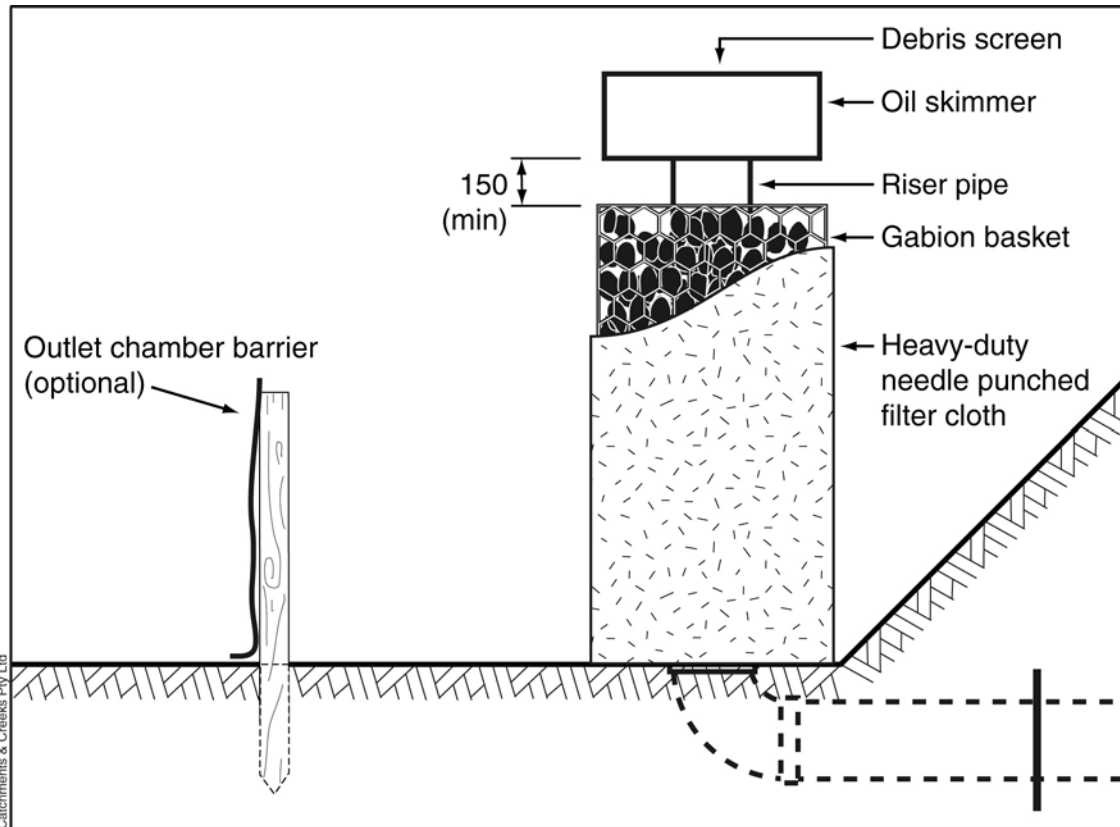

Figure 3 – Typical details of riser pipe outlet with rock-filled gabion baskets

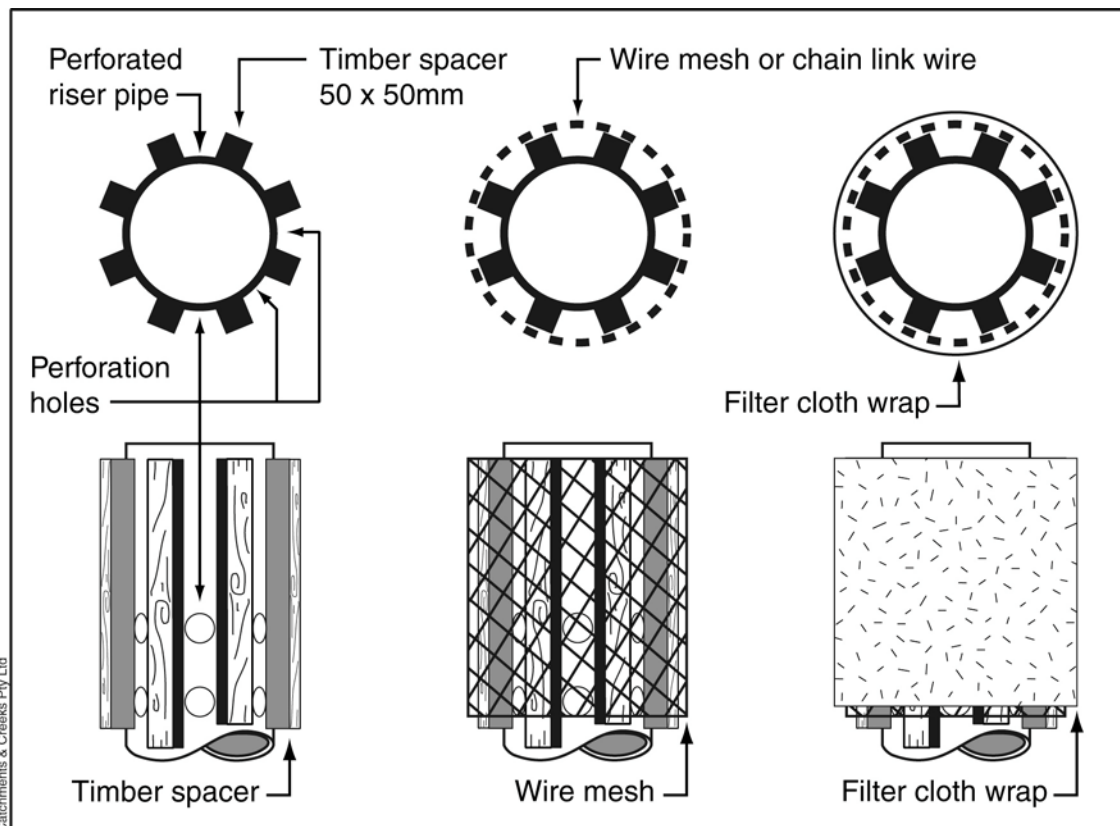

Figure 4 – Typical assembly of riser pipe with filter fabric

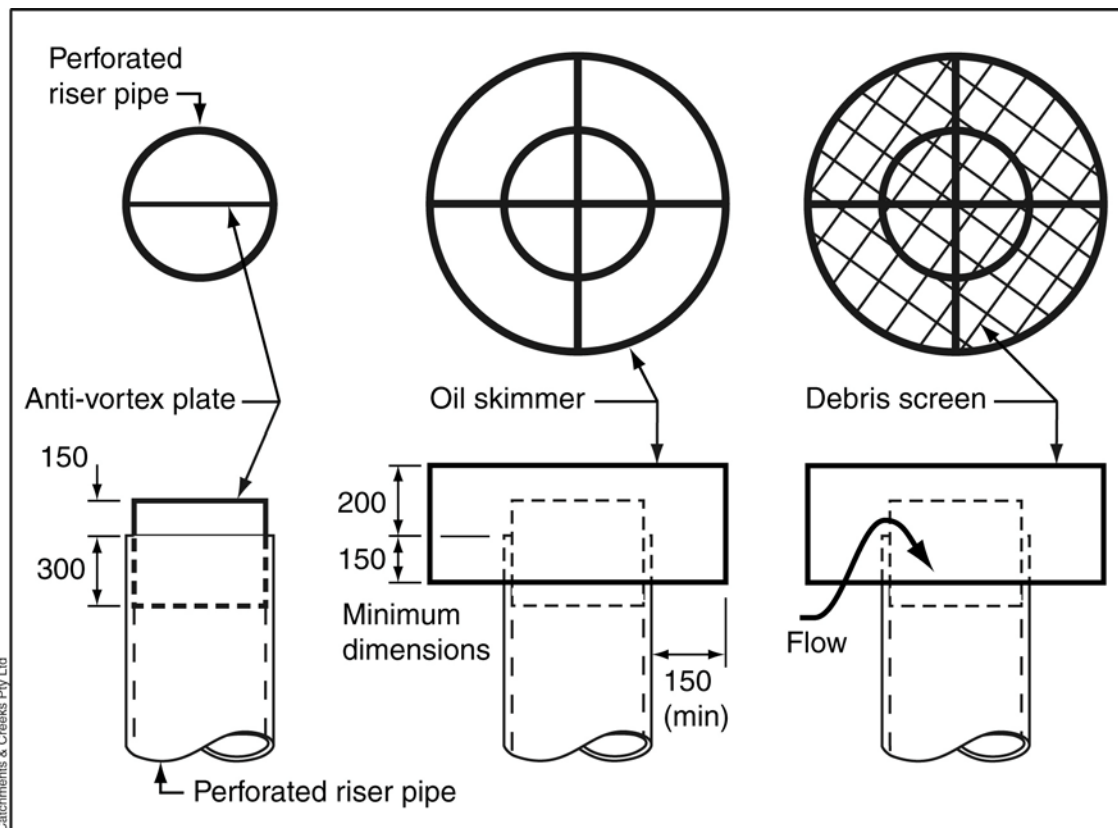

Figure 5 – Typical details of anti-vortex plate, oil skimmer and debris screen

Installation of riser pipe

1. Drill de-watering holes in the riser as specified on the plan.
2. Excavate anti-flotation pit.
3. Securely attach the riser to the conduit or conduit stub to make a watertight structural connection. Secure all connections between conduit sections by approved watertight assemblies.
4. Attach the anti-seep collars to the conduit as shown on the approved plan, or otherwise as specified.
5. Place the conduit and riser on a firm, smooth foundation of impervious soil. Do not use pervious material such as sand, gravel, or crushed rock as backfill around the conduit or anti-seep collars.
6. Place fill material around the conduit in 100mm layers and compact around the pipe to at least the same density as the adjacent embankment. Ensure appropriate care is taken not to raise the pipe from firm contact with its foundation when compacting under the pipe haunches.
7. Place a minimum depth of 600mm of lightly compacted backfill over the conduit before crossing it with construction equipment.
8. Anchor the riser in place by concrete or other satisfactory means to prevent flotation. Ensure the anti-flotation mass is at least 110% of water mass displaced by the riser pipe outlet system, including the volume displaced by the anti-flotation weight.
9. In no case should the conduit be installed by cutting a trench through the dam after the embankment is completed.
10. Attach anti-vortex device and trash guard to riser and as required (refer to specifications shown on the approved plans).

Maintenance

1. Check all visible pipe connections for leaks, and repair as necessary.
2. Remove all trash and other debris from the basin and riser.
3. Submerged inflow pipes must be inspected and de-silted (as required) after each inflow event.

Removal

1. Dispose of all materials in a manner that will not create an erosion or pollution hazard.