

# Rock Filter Dams

## SEDIMENT CONTROL TECHNIQUE

Type 1 System		Sheet Flow		Sandy Soils	✓
Type 2 System	✓	Concentrated Flow	✓	Clayey Soils	✓
Type 3 System	[1]	Supplementary Trap		Dispersive Soils	

[1] Type 3 classification may apply if critical design parameters are not achievable.



**Photo 1 – Rock filter dam with geotextile filter**



**Photo 2 – Rock filter dam with aggregate filter**

### Key Principles

1. Sediment trapping is achieved by both particle settlement within the settling pond formed by the dam (high flows), and by the filtration of minor flows passing through the aggregate and/or geotextile filter.
2. The critical design parameter for optimising particle settlement is the 'surface area' of the settling pond. The hydraulic properties of the rock embankment are critical in achieving the desired stage-discharge relationship to achieve optimum settling pond conditions.
3. The critical design parameters for the filtration process are the design flow rate for water passing through the filter, which is related to the depth of water (hydraulic head), and the surface area and flow resistance of the filter.
4. Geotextile filters provide superior filtration performance, especially within short-term installations; however, their maintenance can be tedious and time-consuming compared to aggregate filters.

### Design Information

*The following design information specifically relates to off-stream installations. The design of rock filter dams located within major stormwater drains and ephemeral waterways is discussed within a separate fact sheet located within the 'Instream Sediment Control' sub-category.*

Rock filter dams may contain up to three different categories of rock, those being:

- The primary core rock, which makes up the bulk of the rock embankment.
- Armour rock, which protects the downstream face of the embankment from overtopping flows, and also used for scour protection downstream of the embankment.
- Filter layer aggregate, which is placed on the upstream face of the rock embankment.

In most cases, the same rock is specified for the core of the embankment as well as the armour protection of the downstream face. The minimum rock size is 225mm nominal diameter for angular (fractured) rock. If round rock is used, a practice **not** recommended, then the minimum nominal rock diameter is 300mm.

The entire embankment should **not** be formed from filter aggregate as shown in Photo 6.

Typical size of filter aggregate is 15 to 25mm nominal diameter.

The use of geotextile filters (minimum 'bidim' A34 or equivalent) is preferred in most construction site situations where the rock filter dam is likely to have an operational life of a few months. For long-term installations, such as on quarry and mine sites, aggregate filters may be preferred to simplify maintenance procedures.

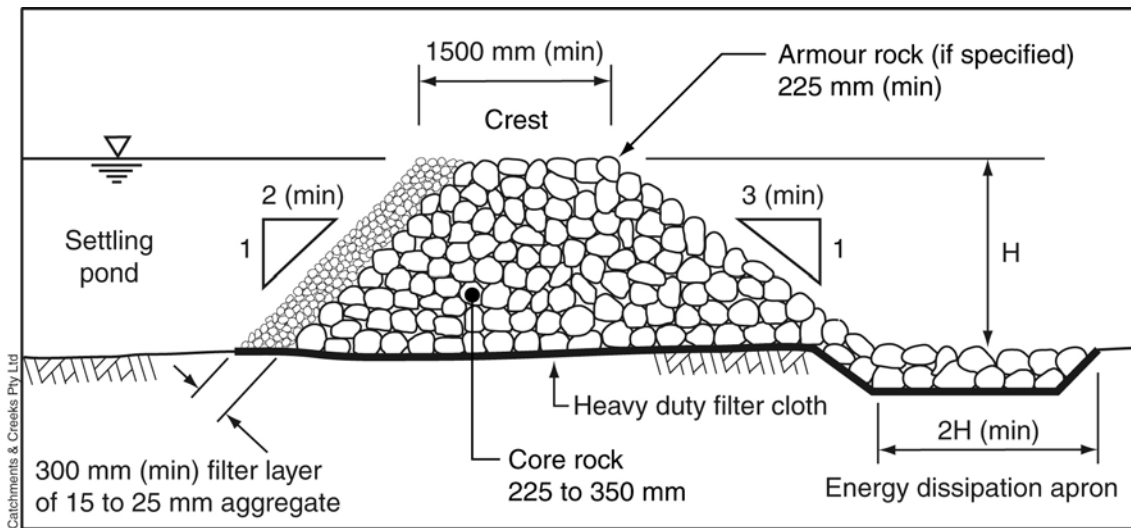

**Figure 1 – Rock filter dam with aggregate filter**

Rock filter dams with geotextile filters (Figure 2) usually require the use of an aggregate layer to achieve the desired stage-discharge flow conditions for the embankment for the purpose of achieving the optimum settling pond conditions (refer to 'Design Procedure' over page).

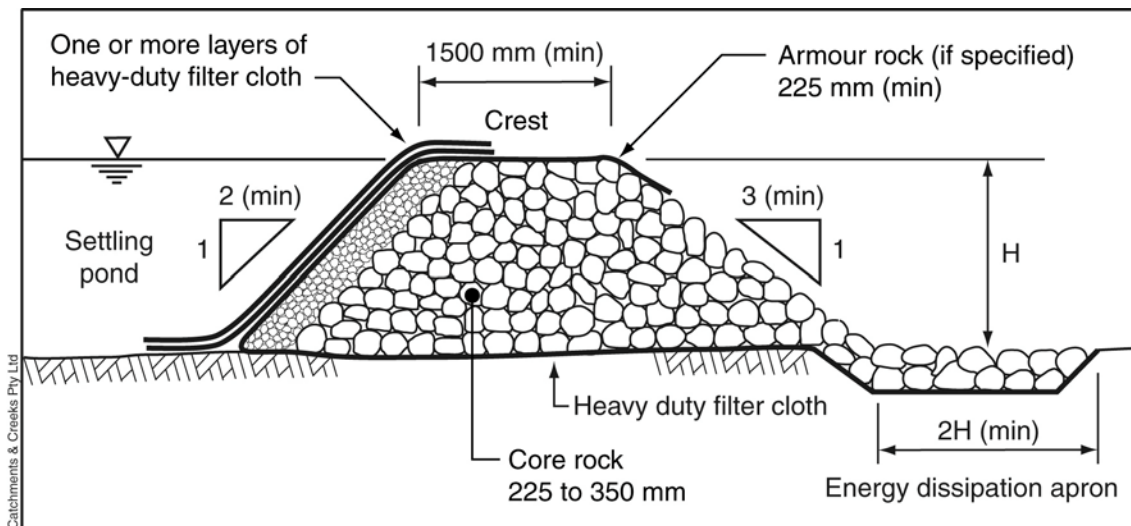

**Figure 2 – Rock filter dam with geotextile (filter cloth) filter**

The geotextile fabric is normally extended over the crest of the rock filter dam to enhance the stability of the spillway crest. Consideration should also be given to the placement of several layers of overlapping fabric (Figure 2), thus allowing each layer to be removed individually once the fabric becomes blocked with sediment.

If an excavated sediment collection pit/trench is incorporated into the settling pond, then the use of a geotextile filter should be considered essential.

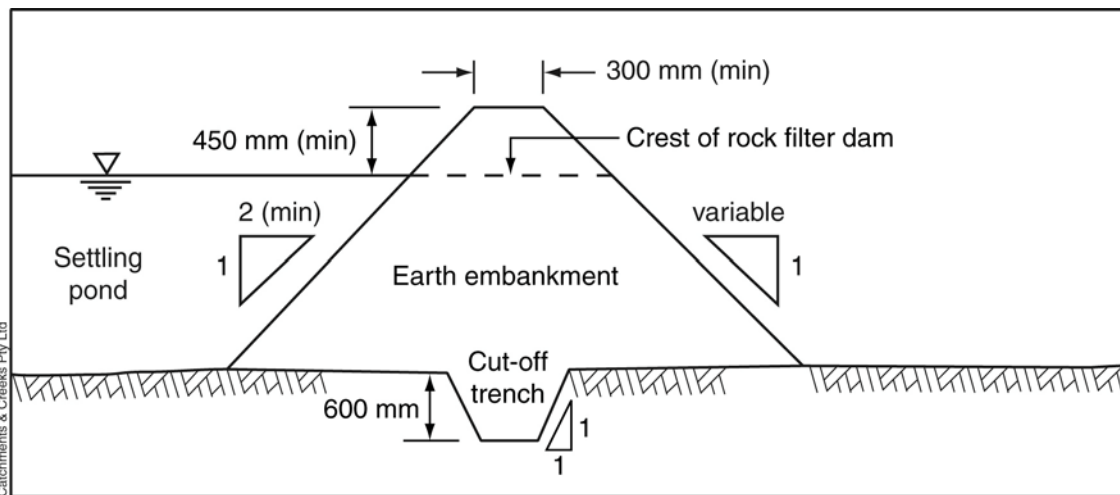

**Figure 3 – Typical dimensional requirements for constructed fill abutments**



Photo supplied by Catchments & Creeks Pty Ltd

**Photo 3 – Sediment collection pit upstream of rock filter dam**



Photo supplied by Catchments & Creeks Pty Ltd

**Photo 4 – Aggregate filter showing partial sediment blockage of lower area**

***Instream rock filter dams:***

The design and operation of instream rock filter dams are discussed in a separate fact sheet located within the *Instream sediment control* section. Instream rock filter dams differ from off-stream structures in the following ways:

- instream designs are normally based on the stream's dry weather flow rate, rather than a specific storm event;
- the entire rock dam is normally wrapped in filter cloth as per Photo 5.



Photo supplied by Catchments & Creeks Pty Ltd

**Photo 5 – Instream rock filter dam wrapped in filter cloth**



Photo supplied by Catchments & Creeks Pty Ltd

**Photo 6 – The entire rock embankment should not be formed from small-diameter aggregate**

## Design Procedure

1. Determine the design flow rate ( $Q$ ) for water passing through the rock embankment just prior to flows overtopping the spillway (Figure 5), as well as the design discharge ( $Q_{WEIR}$ ) for overtopping flows.
2. Determine the desirable settling pond surface area ( $A_s$ ) from Table 1 based on the design flow rate ( $Q$ ). Unless otherwise specified, choose a critical particle size of 0.05mm.
3. Determine the maximum allowable water level within the settling pond. This may be based on site constraints, or related to flooding and/or public safety issues.
4. Determine the required width of the rock filter dam ( $W$ ). The width (perpendicular to the direction of flow) may be limited by site constraints, or controlled by the hydraulic management of overtopping flows. The hydraulic analysis of overtopping flows is normally based on broad-crested weir equations—refer to the separate fact sheet '*Chutes Part 1: General Information*'.
5. Select the required crest elevation of the rock filter dam to achieve the desired settling pond surface area. Ensure the spillway crest is sufficiently below the maximum allowable water elevation to allow for expected overtopping flows (this may be an iterative process).

Where necessary, the settling pond may need to be excavated (expanded) to achieve the required surface area at a given water level.

6. Select the type of filtration system using Table 3 as a guide.
7. Determine the maximum allowable head loss ( $\Delta H$ ) through the rock embankment including filter medium. If flow conditions downstream of the rock filter dam are such that there is little or no backwater effects during the design storm, then assume  $\Delta H$  is equal to the height of the rock filter dam ( $H$ ).

If flow depths downstream of the rock filter dam are expected to be significant, then the maximum allowable head loss ( $\Delta H$ ) should be taken as the expected variation in water level across the dam during the design discharge.

8. Select a 'design' blockage factor (B.F.) using Table 4 as a guide.
9. Use the design information provided below to determine the make-up and thickness of the filter medium required to achieve the desired stage–discharge relationship.
10. If the available pond surface area is insufficient to settle the required particle size, then the efficiency of the sediment trap may be improved by placing filter cloth across the upstream face of the rock filter dam (if not already used). In addition, *Filter Tubes* (refer to *Filter Tube Dams*) can be incorporated into the dam. Note the filter tube intake pipes would need to be set at an elevation above the expected settled sediment depth.
11. Determine the rock size required for the spillway (i.e. downstream face of the rock embankment). Refer to section (d) below and Table 2.
12. If excessive quantities of sediment are likely to enter the dam, then assess the benefits of excavating a sediment collection pit just upstream of the dam (Photo 3).
13. Assess the need for safety fencing to be placed around the settling pond.

### **(a) Settling pond:**

Table 1 provides the required pond surface area per unit flow rate for various nominated 'critical' sediment particle sizes. The critical sediment particle size for a rock filter dam may be assumed to be 0.05mm unless otherwise directed. The chosen critical sediment size should reflect the environmental values of the receiving water body and the expected weather conditions. In some cases the critical particles size will be specified within a local Stormwater Management Plan, or Erosion and Sediment Control Standard.

Ideally, the settling pond should have a length (in the main direction of flow) at least three times its average width. If the pond length is less than three times its average width, or the inflow is primarily through the discharge of a high velocity pipe (resulting in inflow 'jetting'), then the pond area should be increase by 20% from the values presented in Table 1.

It is noted that achieving the minimum pond surface area may not be practicable in all circumstances, in which case a greater focus should be placed on the design of the filter medium placed on the upstream face of the dam.

**Table 1 – Minimum settling pond surface area per unit inflow rate**

Design standard	Critical sediment size (mm)	Surface area of settling pond per unit discharge (m <sup>2</sup> /m <sup>3</sup> /s) <sup>[1]</sup>			Allowable through-velocity (m/s)
		10° C <sup>[2]</sup>	15° C <sup>[2]</sup>	20° C <sup>[2]</sup>	
Type 3 sediment trap	0.50	6	5.2	4.6	0.3
	0.20	38	33	29	0.3
	0.15	67	60	52	0.3
Type 2 sediment trap	0.10	150	130	115	0.2
	0.05	600	525	460	0.2
Type 1 sediment trap	0.04	940	820	720	0.2
	0.02	3700	3230	2860	0.2

[1] Pond area is based on a rectangular pond operating with uniform inflow conditions across its width.

[2] Assume a pond temperature the same as the typical rainwater temperature during the time of year when the pond is likely to be operating at capacity.

**(b) Earth abutments:**

If the rock filter dam abuts into constructed earth embankments (Figures 3 & 4), then such embankments should be formed with stable bank slopes appropriate for the soil conditions. Typically bank slopes should not be steeper than 2:1 (H:V) if temporary, or 4:1 if the embankments are grassed and are required to be mown.

The crest of constructed earth embankments should be at least 450mm above the spillway crest of the rock filter dam if the embankments have an operational life less than 12 months, with a minimum freeboard above the design maximum settling pond water level of 150mm. If the earth embankments have an operational life greater than 12 months, then an appropriate allowance should be made for settlement of any constructed embankments.

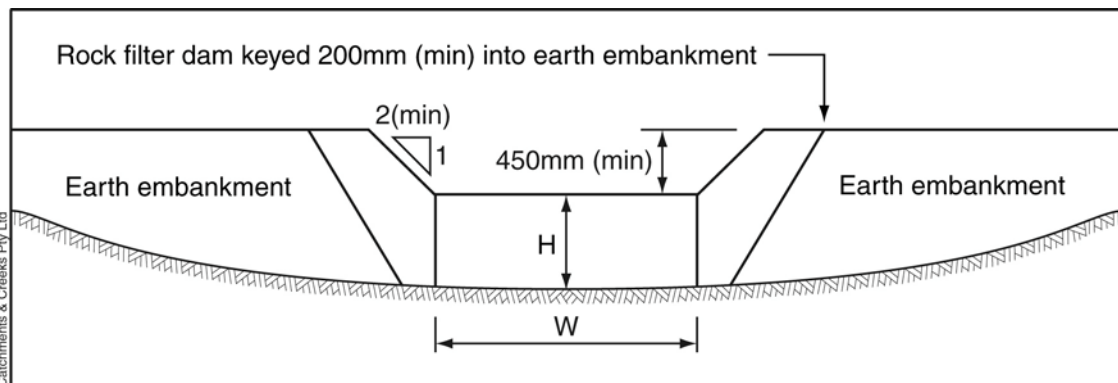

**Figure 4 – Rock filter dam integrated into fill embankments**

Earth embankments are normally keyed into the natural soil with the use of a 600mm deep cut-off trench (Figure 3) that both anchors the embankment and reduces the risk of damaging seepage flows under the embankment.

**(c) Rock embankment:**

Minimum desirable top width (in direction of flow) = 1.5m.

Maximum height at centreline of the embankment = 1.5m. Otherwise the design should be assessed for stability by a suitably qualified person (e.g. geotechnical engineer).

Maximum side slopes of 2:1(H:V) on the up-slope face, and 3:1(H:V) on the down-slope face.

Rock abutments should extend at least 450mm (in elevation) above the spillway crest.

The primary core rock should be well graded, hard, erosion resistant stone. Minimum mean rock size ( $d_{50}$ ) of 225mm, and a maximum of 350mm. If the rock size required for scour protection on the downstream face is greater than 350mm, then separate 'core' and 'armour' rock should be specified.

The rock embankment should be embedded at least 200mm into the bed and the adjacent earth banks (if any) to prevent water tunnelling beneath or around the rock embankment.

Prior to the placement of the rock, the entire excavated foundation area, including any earth abutments, must be covered by heavy-duty filter cloth (minimum 'bidim' A34 or equivalent) with minimum 600mm overlap at joints.

**(d) Emergency spillway (downstream face of embankment):**

Guidance on the hydraulic analysis of broad-crested weirs is provided in the separate fact sheet 'Chutes Part 1: General Information' located within the Drainage Structures sub-category.

The maximum design storm ( $Q_{MAX}$ ) is typically the 1 in 2 year ARI (average recurrence interval) design storm, but may be 1 in 5 year, or 1 in 10 year ARI depending on the safety risks associated with hydraulic failure of the dam.

The design flow rate for the overtopping weir ( $Q_{WEIR}$ ) is the difference between the maximum design storm flow rate ( $Q_{MAX}$ ) and the design flow rate for the filter medium ( $Q$ ).

Desirable longitudinal gradient of spillway no steeper than 3:1(H:V), absolute maximum of 2:1.

Spillway crest should be flat and perpendicular to the alignment of the spillway chute.

Side slope of spillway section no steeper than 2:1(H:V).

Minimum effective depth of the spillway chute is 300mm.

Minimum thickness of armour rock lining is 500mm, or twice the nominal rock size, whichever is larger (if specifications for the armour rock are different from that of the embankment core rock).

The required mean rock size can be determined from either of the following:

- 'Chutes Part 5: Rock linings' fact sheet, see the 'Drainage Structures' sub-category;
- 'Rock Linings' fact sheet, see the 'Channel and Chute Linings' sub-category;
- Table 2, assuming angular rock with a specific gravity of 2.4, and safety factor of 1.2.

**Table 2 – Flow depth <sup>[1]</sup>, y (m) and mean rock size,  $d_{50}$  (m) for SF = 1.2**

Safety factor, SF = 1.2		Specific gravity, $s_r = 2.4$				Size distribution, $d_{50}/d_{90} = 0.5$		
Unit flow rate ( $m^3/s/m$ )	Bed slope <sup>[2]</sup> = 5:1		Bed slope = 4:1		Bed slope = 3:1		Bed slope = 2:1	
	y (m)	$d_{50}$	y (m)	$d_{50}$	y (m)	$d_{50}$	y (m)	$d_{50}$
0.1	0.09	0.10	0.09	0.10	0.09	0.20	0.09	0.20
0.2	0.15	0.20	0.14	0.20	0.14	0.20	0.14	0.30
0.3	0.19	0.20	0.19	0.20	0.19	0.30	0.18	0.30
0.4	0.23	0.30	0.23	0.30	0.23	0.30	0.22	0.40
0.5	0.27	0.30	0.27	0.30	0.26	0.40	0.26	0.40
0.6	0.31	0.30	0.30	0.40	0.30	0.40	0.29	0.50
0.8	0.37	0.40	0.37	0.40	0.36	0.50	0.35	0.60
1.0	0.43	0.40	0.42	0.50	0.42	0.60	0.41	0.70
1.2	0.49	0.50	0.48	0.50	0.47	0.60	0.46	0.70
1.4	0.54	0.50	0.53	0.60	0.52	0.70	0.51	0.80
1.6	0.59	0.60	0.58	0.70	0.57	0.70	0.56	0.90
1.8	0.64	0.60	0.63	0.70	0.62	0.80	0.60	1.00
2.0	0.68	0.70	0.67	0.70	0.66	0.90	0.65	1.00

[1] Uniform flow depth down face of spillway is expected to be highly variable due to turbulence.

[2] Bed slope is the slope of the spillway (i.e. downstream face of the rock filter dam).

**(e) Downstream channel protection:**

A rock apron at least 500mm thick should extend downstream from the toe of the dam (at zero gradient) a sufficient distance to prevent channel erosion, or a distance equal to twice the height of the dam, whichever is the greater. This rock apron should blend seamlessly with the spillway.

**(f) Filter medium:**

The entire upstream face of the rock structure should be covered with an appropriate filter media. The properties of the various filter media are presented in Table 3.

**Table 3 – Properties of various filter media**

Type	Material	Properties
Filter cloth	Heavy-duty filter cloth (minimum 'bidim' A34 or equivalent) one or more layers	Short-term sediment traps (< 12-months). Medium trapping efficiency. Possible high maintenance requirements (the aim is for the operational life of the trap to be less than the time required for the fabric to block with sediment).
Aggregate	Minimum 300mm thick layer of 15 to 25mm aggregate	Short to medium-term traps (6 to 12-months). Initially poor filtering capacity until partial sediment blockage of the aggregate occurs, after which medium trapping efficiency. Medium maintenance requirements.
	Minimum 300mm thick layer of 25 to 75mm aggregate	Long-term sediment traps (> 12-months). Low trapping efficiency. Low to medium maintenance requirements.

The filter medium is required to perform the following two tasks:

- slow the passage of water through the embankment so that an upstream settling pond will form with the required surface area to allow adequate gravitational settlement; and
- filter sediment from the water that passes through the filter medium.

**(g) Aggregate filter hydraulics:**

The head loss ( $\Delta H$ ) of a rock filter can be determined using Equation 1, which is based on the dimensions of an equivalent rectangular rock-filled medium.

$$\Delta H^{1.5} = \frac{1000 \cdot Q \cdot T^{0.5}}{B \cdot F \cdot [15.2 - 0.0068(d)] \cdot W \cdot d^{0.5}} \quad (\text{Eqn 1})$$

Notes on Equation 1:

- It is assumed that the effective height of the rock filter (H) is equal to the head loss ( $\Delta H$ ) through the structure, i.e. it is assumed that there is no hydraulic back pressure on the downstream face of the rock filter.
- The equation was developed from research work presented by Jiang et al., within Fifield (2001).
- Given the complexity of many rock filters, the equation may not be accurate in all circumstances, but is assumed to be satisfactory for design purposes.

If the core of the rock embankment contains rock larger than 100mm in diameter, then it may be assumed that this rock does not provide any measurable hydraulic resistance to the passage of water through the dam.

Alternatively, if the maximum allowable head loss ( $\Delta H$ ) is known, then the allowable flow rate (Q) can be determined using Equation 2.

$$Q = (B \cdot F) \cdot [15.2 - 0.0068(d)] \frac{W \cdot \Delta H^{1.5} \cdot d^{0.5}}{1000 T^{0.5}} \quad (\text{Eqn 2})$$

where:

- Q = Flow rate (assuming no blockage) [m<sup>3</sup>/s]
- d = mean (d<sub>50</sub>) size of the filter rock [mm]
- W = width of rock filter dam across the direction of flow [m]
- ΔH = head loss through rock filter [m]
- T = thickness of rock filter in the direction of flow [m]

**Table 4 – Blockage factors for filter mediums**

Blockage factor (B.F.)	Appropriate usage
1.0	When assessing the 'As Constructed' maximum flow rate.
0.9	Sediment traps operating in coarse-grained soils where the runoff of fine silts and clays is expected to be only minor.
0.5	Default design value. Sediment traps likely to experience more than one storm event.

Ideally, the rock filter dam should be able to fully discharge (de-water) the settling pond over **no less** than 8 hours to allow sufficient time for particle settlement. Settling ponds that can drain (from full) in less than 8 hours may not achieve optimum sediment capture. Settling ponds that drain (from full) over a period greater than 8 hours may indicate the need for maintenance of the filter medium.

**(h) Filter cloth hydraulics:**

The head loss through a layer of filter cloth can be determined from the permittivity (ψ) of the reported fabric in accordance with AS 3706-9.

$$\Delta H = \frac{Q}{(B.F.).A.\psi} \quad (\text{Eqn. 3})$$

where:

- ΔH = Hydraulic head loss through geotextile [m]
- Q = Total flow rate through the geotextile [m<sup>3</sup>/s]
- A = Surface area of the geotextile [m<sup>2</sup>]
- ψ = Permittivity of the geotextile (AS 3706-9) [s<sup>-1</sup>]

Notes on Equation 3:

- Equation 3 assumes hydraulic pressure (i.e. water) exists on both sides of the fabric, i.e. the cloth is not 'damming' the water like most woven fabrics do.

The permittivity for various grades of 'bidim' filter cloth can be determined from Table 5.

**Table 5 – Flow rate per unit width for various grades of 'bidim' filter cloth (no blockage allowance)**

bidim grade =	A12	A14	A24	A29	A34	A44	A64
Flow rate @ 100mm head <sup>[1]</sup> (L/s/m <sup>2</sup> )	512	454	342	242	217	161	118
Permittivity (AS 3706-9) 'ψ' (s <sup>-1</sup> )	5.12	4.54	3.42	2.42	2.17	1.61	1.18

[1] Manufacturer's specified flow rate at a constant head of 100mm based on AS 3706-9.

**Reference:**

Fifield, J.S. 2001, *Designing for Effective Sediment and Erosion Control on Construction Sites*. Forester Communications, California. ISBN 0-9707687-0-2.



Two design flow rates are used in the design of rock filter dams. The low flow rate ( $Q$ ) is the flow rate required to pass through the filtration system just prior to flows overtopping the spillway (Figure 5). The maximum design flow condition ( $Q_{WEIR}$ ) is when peak waters are achieved within the settling pond (Figure 6).

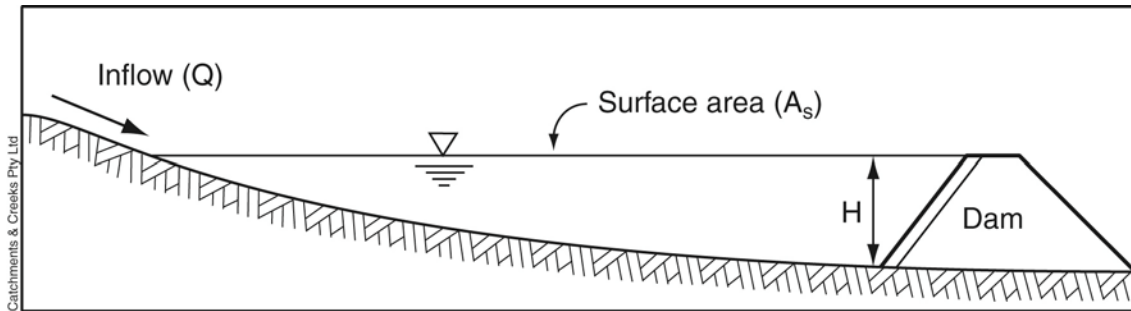

Figure 5 – Minimum design flow condition

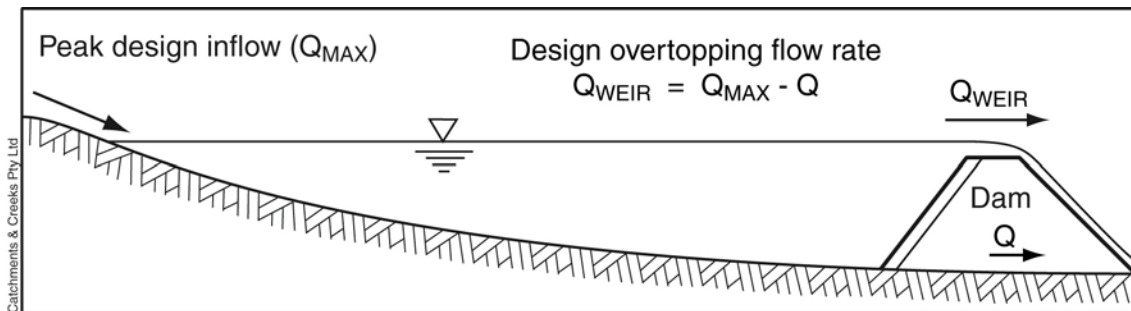

Figure 6 – Maximum design flow condition

Figures 7 to 11 provide examples of typical rock filter dam profiles and the equivalent filter barrier hydraulic analysis profile.

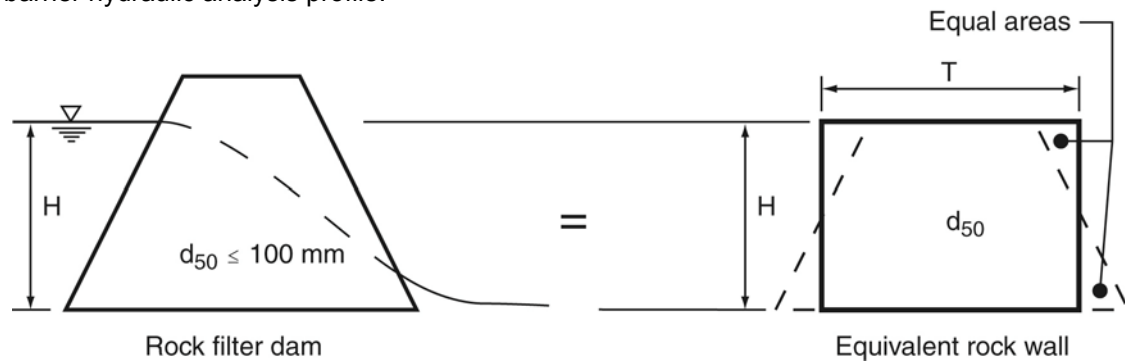

Figure 7 – Rock filter dams formed only from small filter rock (not recommended)

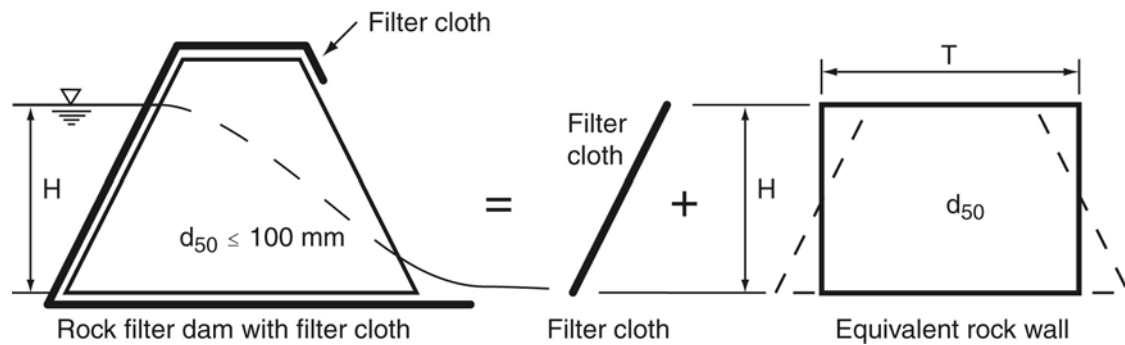
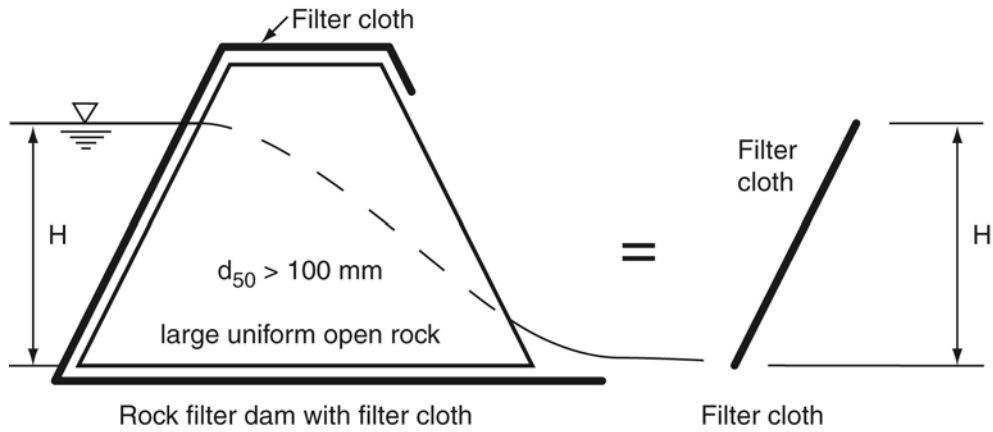
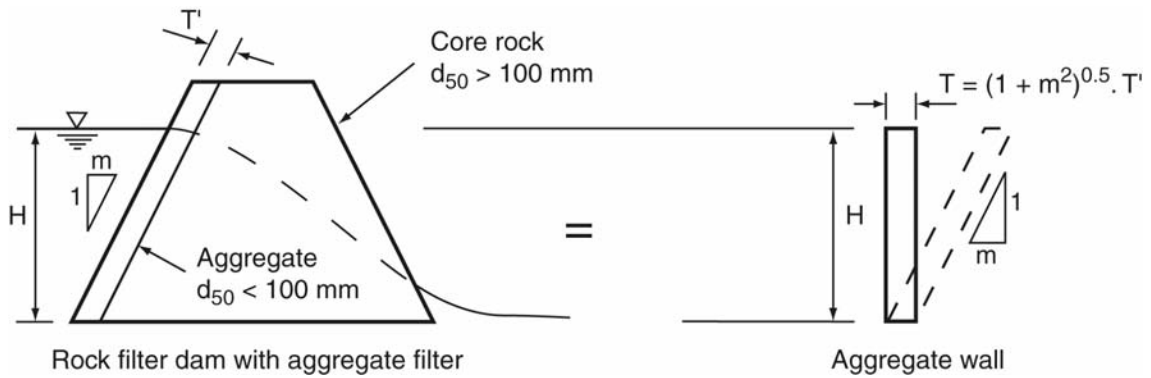

Figure 8 – Rock filter dam formed from small filter rock with upstream filter cloth



**Figure 9 – Rock filter dam formed from large, free-draining rock with upstream filter cloth**



**Figure 10 – Rock filter dam formed from large, free-draining rock with upstream aggregate filter**

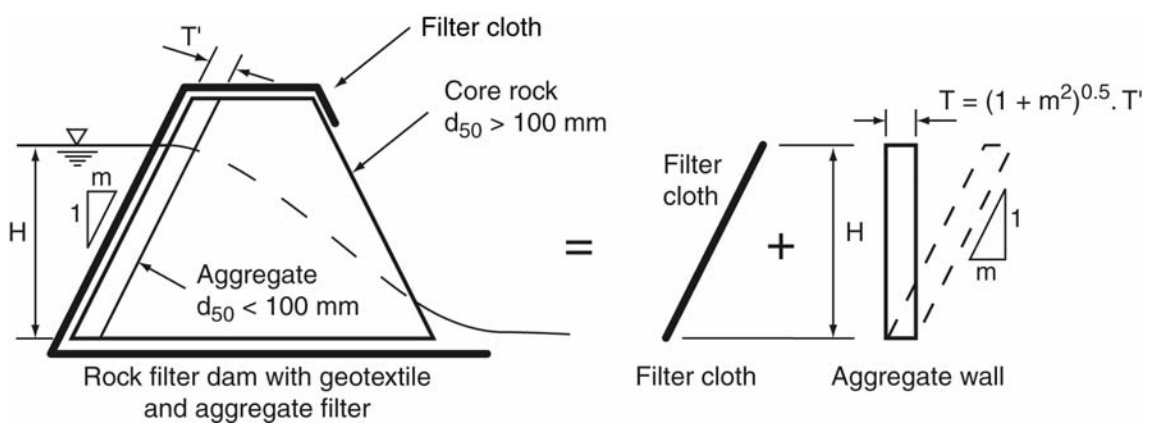

**Figure 11 – Rock filter dam formed from large, free-draining rock with combined geotextile and aggregate filter**

## **Description**

A rock embankment usually constructed from large uniform-sized rocks, with a filter medium placed on the upstream face of the embankment. The filter medium typically consists of either one or more layers of filter cloth, and/or a layer of aggregate.

The downstream face of the rock embankment usually acts as a spillway.

In some regions these systems are referred to as 'Type B' sediment traps, or just 'sediment traps'.

## **Purpose**

Typically used as a Type 2 sediment trap, but can be classified as a Type 3 sediment trap if the settling pond has insufficient surface area.

Most commonly used as a sediment trap at the end of minor table drains and drainage channels with a catchment area less than 0.25ha.

## **Limitations**

Limited ability to control turbidity levels or trap fine sediments, except during periods of low flow.

## **Advantages**

The rock dams are generally durable structures that rarely experience accidental damage as compared to most Type 3 sediment traps.

Rock aggregate filters are easy maintained (i.e. replaced) during maintenance operations.

## **Disadvantages**

The filter medium may regularly block with sediment requiring its replacement.

Geotextile filters are very difficult to replace once covered in mud.

Fine sediments (e.g. clay particles) readily pass through most rock filter dams.

## **Special Requirements**

The larger embankment rock provides the structural stability and acts as the spillway for overtopping flows.

The rock embankment should be embedded at least 200mm into the bed and the adjacent earth banks (if any) to prevent water tunnelling beneath or around the rock embankment.

Suitable access must be provided for maintenance.

Safety risks associated with the settling pond and its backwater (flooding) effects must be given appropriate consideration. The settling pond may need to be surrounded by safety fencing.

An excavated sediment collection pit may be formed immediately upstream of the rock embankment to reduce the risk of sediment blockage of the filter medium, and to reduce the required frequency of maintenance. However, it is noted that aggregate filters rely on partial sediment blockage to achieve optimum filtration properties.

Given the above, the short-term performance of aggregate filters can be impaired if a sediment collection pit is included. While on the other hand, the long-term performance of geotextile filters can benefit from the incorporation of a sediment collection pit.

## **Location**

Small, low risk catchment areas typically less than 0.25ha.

Sediment traps located within minor table drains and drainage channels.

A rock filter dam can form the outlet structure on a *Sediment Trench* or de-watering *Settling Pond*.

## **Site Inspection**

Check the clarity of the outflow downstream of the dam.

Check the choice and performance of the filter medium.

Check the dimensions of the settling pond.

Check for potential flows bypassing the filter medium.

Check that the bank slopes are 2:1 (H:V) or flatter.

Check for displacement of rock.

Check available sediment storage capacity.

Check if the trap requires maintenance or sediment removal.

## Materials

- Primary core rock: well graded, hard, angular, erosion resistant rock, with mean size as specified in the approved plan, but not less than 225mm, or greater than 350mm.
- Armour rock: well graded, hard, angular, erosion resistant rock, with mean size as specified in the approved plan, but not less than 225mm.
- Aggregate filter: 15 to 25mm clean aggregate.
- Geotextile filter fabric: heavy-duty non-woven, needle-punched filter fabric, minimum 'bidim' A34 or equivalent.

## Installation

1. Refer to approved plans for location and construction details. If there are questions or problems with the location, or method of installation, contact the engineer or responsible on-site officer for assistance.
2. Clear the foundation area of the rock filter dam of woody vegetation and organic matter. Delay clearing the up-slope pond area until the dam is formed and is able to act as a suitable sediment trap, otherwise an alternative temporary downstream sediment trap may be required during construction of the rock filter dam.
3. If specified on the plans, excavate a cut-off trench along the centre-line of the dam and earth abutments (if any).
4. Cover the foundation area and cut-off trench with heavy-duty filter fabric before backfilling with the core rock. Overlap adjoining fabric sheets a minimum of 600mm.
5. Construct the associated earth abutment (if any). All cut and fill slopes should be 2:1(H:V) or flatter. The downstream face of earth abutments should be 3:1(H:V) or flatter. Earth abutments should be constructed of well-compacted, erosion resistant soil that is free of vegetation and roots. Overfill earth abutments 150mm to allow for settlement.
6. Place the core rock for the rock filter dam. Ensure the upstream face is 2:1(H:V) or flatter, and the downstream face is 3:1(H:V) or flatter.
7. Ensure the rock is machine placed with the smaller rocks worked into the voids of the larger rocks.
8. If specified, construct the spillway section using the specified armour rock. The spillway should have a minimum profile depth of 300mm. The spillway weir crest must be level across its full width. The maximum longitudinal slope of the rock spillway should be 3:1(H:V). The minimum thickness of armour rock protection should be 500mm, or twice the nominal rock size, whichever is the greater.
9. Ensure the spillway outlet section extends downstream past the toe of the formed embankment until stable conditions are reached, or a distance equal to the height of the dam, whichever is the greater. The edges of the spillway should be left flush with the surrounding ground.
10. Install the specified filter (aggregate and/or filter cloth) on the upstream face of the rock filter dam.
11. If filter cloth is used, then:
  - (i) extend the fabric over the crest of the rock filter dam into the spillway chute;
  - (ii) consider the placement of several layers of overlapping fabric, thus allowing each layer to be removed individually once the fabric becomes blocked with sediment.
12. Clear the settling pond area of woody vegetation and organic matter to the dimensions specified within the plans.
13. Where necessary, excavate the upstream settling pond and/or sediment storage pit in accordance with the approved plans. Excavated pits typically have side slopes of 2:1(H:V) or flatter unless steeper slopes are known to be stable.
14. Stabilise any associated earth embankments immediately after construction through appropriate compaction, vegetation and/or erosion control matting.
15. Establish all necessary up-slope drainage control measures to ensure that sediment-laden runoff is appropriately directed into the sediment trap.
16. Take all necessary measure to minimise the safety risk caused by the structure.

## **Maintenance**

1. Check all rock filter dams after each runoff event and make repairs immediately.
2. Inspect all rock and earth embankments for undercutting or undesirable seepage flows.
3. Ideally, rock filter dams should discharge (from full) over no less than 8 hours. If drainage is too rapid, then additional filter aggregate may be required to achieve optimum hydraulic performance.
4. If flow through the structure is reduced to an unacceptable level, the upstream filter medium (aggregate or filter cloth) should be removed and replaced.
5. If a greater degree of water treatment (filtration) is required, extra geotextile filter fabric should be placed over the upstream face of the structure.
6. Check the structure and downstream channel banks for damage from overtopping flows. Make repairs as necessary.
7. Immediately replace any rock displaced from the spillway.
8. Remove sediment and restore original sediment storage volume when collected sediment exceeds 10% of the specified storage volume.
9. Dispose of sediment and debris in a manner that will not create an erosion or pollution hazard.

## **Removal**

1. When the up-slope drainage area has been stabilised, remove all materials included deposited sediment and dispose of in a suitable manner that will not cause an erosion or pollution hazard.
2. All water and sediment should be removed from the settling pond prior to the dam's removal. Dispose of sediment and water in a manner that will not create an erosion or pollution hazard.
3. Bring the disturbed area to a proper grade, then smooth, compact and stabilise and/or revegetate as required to minimise the erosion hazard.