

(a) Typical installation of modular sediment barrier on the bed of a watercourse

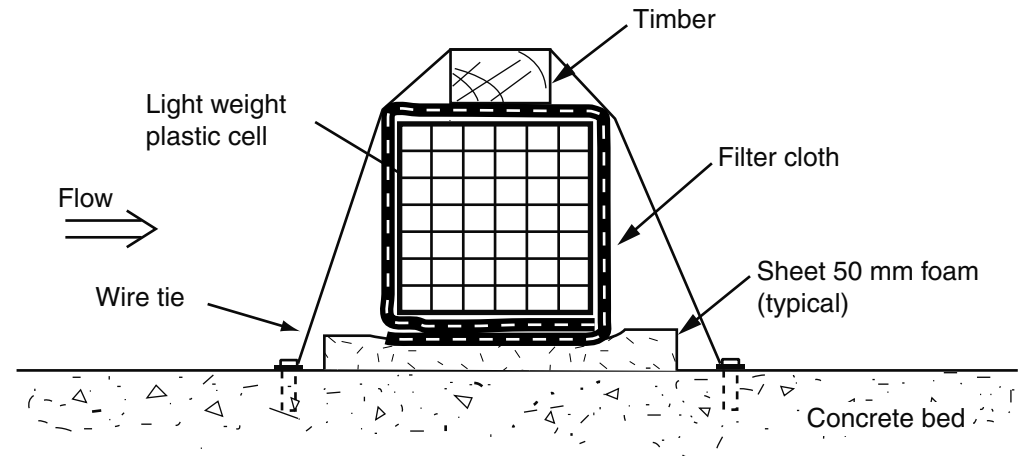

(b) Typical installation of modular sediment barrier within a concrete-lined channel

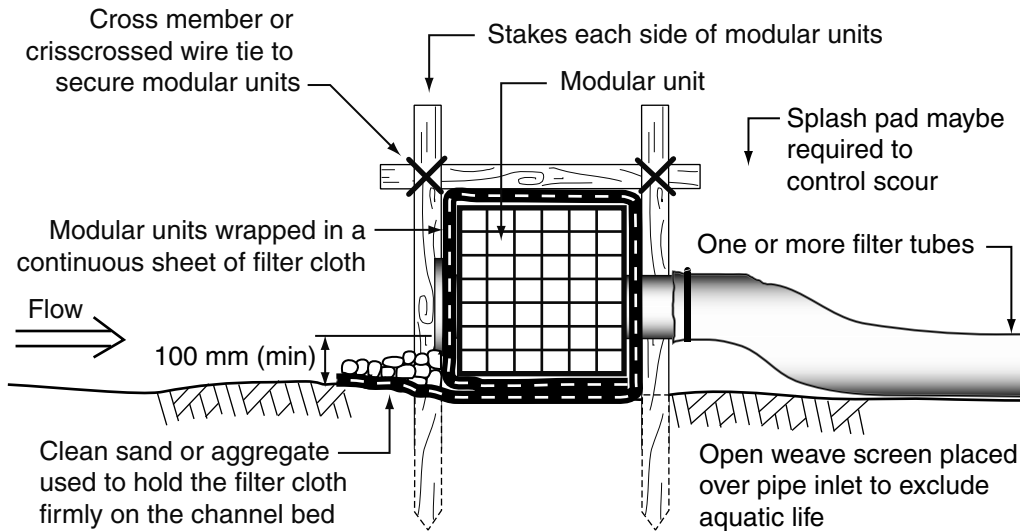

(c) Modular sediment barrier with integrated filter tube

Notes:

1. The use of timber stakes is just one method of anchoring the modular units.
2. Alternative anchoring methods maybe used so long as the anchoring system is able to suitable restrain the units against expected hydraulic forces.
3. It is important to ensure a good contact is achieved between the modular units and the ground surface to prevent leakage.

Drawn:	Date:		
GMW	Feb-10	Modular Barrier (Instream)	MSB-01